



# Flat Flexible Cables

AXOJUMP<sup>®</sup>

# Flat Cables

## FFC-Flat Flexible Cables AXOJUMP™

Designed for board-to-board interconnections in electronic systems, Axojump™ Flat Flexible Cables (FFC) are made up of flat tin or gold plated copper conductors insulated with Polyester or Polyimide tapes. From 0.30 mm pitch for space saving to 1.25 mm, a large variety of pitches is available to suit your needs. In addition to the standard range, AXON' has developed custom designed flat flex cables incorporating folds, shields, notches, punching, slitting or marking. Flat Flexible Cables are compatible with ZIF and LIF connectors.



## 0.30 mm pitch Flat Flexible Cables

### General characteristics

Temperature rating: up to 105°C.

Voltage rating: up to 30V AC.

### Conductor

Pitch: 0.30 mm.

Width:  $0.20 \pm 0.015$  mm.

Conductor thickness: 0.035 mm typical value.

Max. conductor resistance: 2800 ( $\Omega$ /km) at 20°C.

### Conductor plating

Gold: 0.3 $\mu$ m Ni (mini) / 0.05 $\mu$ m Au.

### Insulation

Polyester insulation with flame retardant adhesive.

White colour.

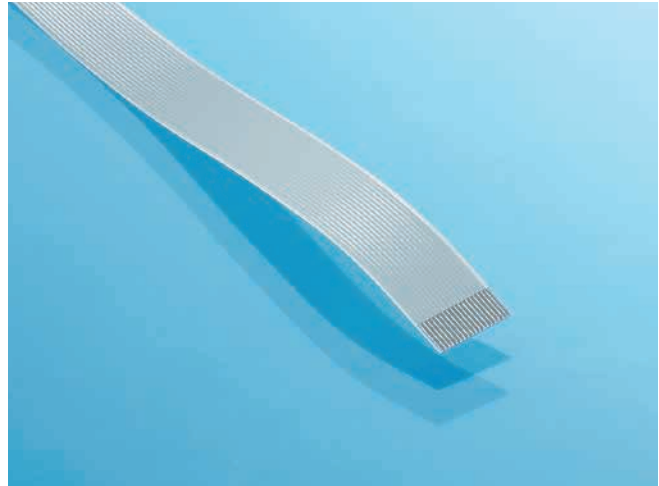

0.30 MM PITCH STANDARD FLAT FLEXIBLE CABLE.

### Connection scheme

#### With ZIF connectors

- Reinforcement tape: Polyester L code.
- Blue colour.



### General drawing

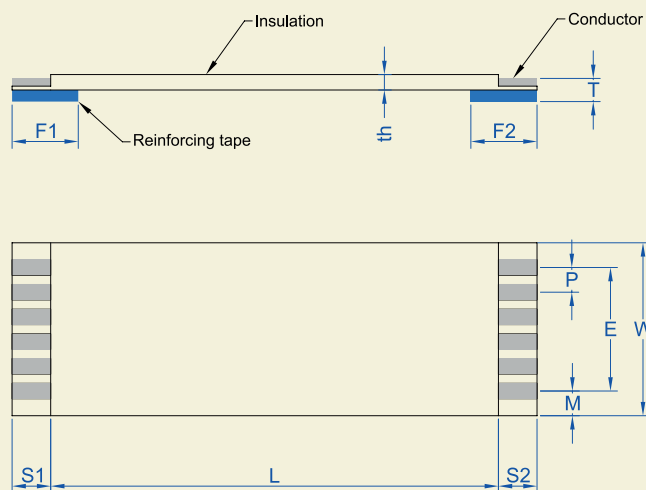

## 0.30 mm pitch Flat Flexible Cables

### Processing forms

#### Type A

Reinforcements at both ends,  
on the same side.

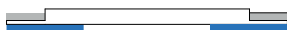

#### Type D

Reinforcements at both ends,  
on opposing side.

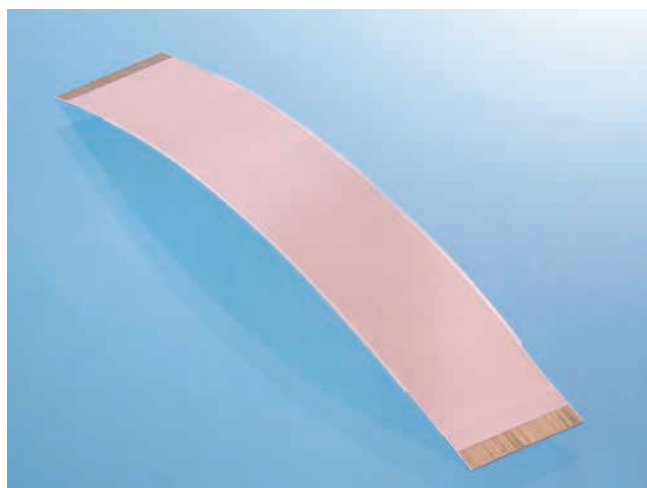
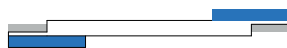

0.30 MM PITCH GOLD PLATED FLAT FLEXIBLE CABLE.

### Dimensions

Pitch: P (mm)	$0.30 \pm 0.03$
Number of conductors: N	11 to 51
Span: E (mm)	$(N-1) \cdot 0.30 \pm 0.03$
Width: W (mm) (on connection area)	$(N+1) \cdot 0.30 \pm 0.03$
Margin: M (mm)	$0.30 \pm 0.05$
Strip length: S1-S2 (mm)	$4.00 \pm 0.80$
Reinforcement length: F1-F2 (mm)	$8.00 \pm 2.00$
Insulated length: L (mm)	42 to $60 \pm 2$ 61 to $100 \pm 3$ 101 to $200 \pm 4$ 201 to $500 \pm 5$
Thickness at end of cable: T (mm)	$0.20 \pm 0.03$
Cable thickness: th (mm)	0.12 (typical value)

## 0.30 mm pitch Flat Flexible Cables

## Electrical properties

	Testing conditions	Values
Dielectric Test (V AC) - Min	Conductor to conductor, during 1 minute	100
Current rating (A) - Max	FFC at 23°C Allowable temperature rise : 40°C	0.30
Insulation resistance (MΩ.m min)	Conductor to conductor	10 at DC 100V
Continuity test	DC 3.0 V at 0.1mA	Passed
Impedance cond/cond balanced method (typical value)	FFC without shielding at 1MHz	145 Ω
Capacitance cond/cond balanced method (typical value)	FFC without shielding at 1KHz	70 pF/m

## Other properties

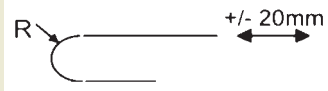
	Testing conditions	Characteristics	
Heat resistance	113°C, 168 hours	Dielectric test Insulation resistance	Passed Passed
Thermal shock	(-55°C x 30 min → 25°C x 5 min → 85°C x 30 min → 25°C x 5 min) x 25 cycles	Dielectric test Insulation resistance	Passed Passed
Cold coiling	-40°C, 96 hours The sample is initially wound on a mandrel of 3 mm	At room temperature: Visual inspection Dielectric test Insulation resistance	Passed Passed Passed
Wear by abrasion	Test following EN3475-503 Weight: 500 g Speed: 60 cycles/min Abrasion tool: Ø = 0.50 mm	Dielectric test Insulation resistance: After 500 cycles	Passed
Flame resistance	UL 758	VW-1	Passed
Folding	The specimen is folded manually at 180°	Continuity after more than 20 times	Passed
Moisture resistance	60°C, 95% RH, 96 hours	Dielectric test Insulation resistance	Passed Passed
Flex-life Number of cycles (typical values)	Speed 100 cycles /min Flex-life test is performed at 23°C. 	Radius 10 mm	500 000

## 0.30 mm pitch Flat Flexible Cables

### Identification code

**FFC 0.30 A 25/0200 E 4.0-4.0-08.0-08.0 E A LL/AU**

#### Option:

Plating on conductors  
**AU:** gold plating

#### Reinforcement type (F1 & F2):

**L:** Polyester reinforcement

#### UL compliance:

**A:** No compliance

Conductor thickness: **E** (35 microns)

Reinforcement **length F2** in mm  
 (8 mm standard length)

Reinforcement **length F1** in mm  
 (8 mm standard length)

Strip **length S2** in mm (4 mm standard length)

Strip **length S1** in mm (4 mm standard length)

Insulation: **E**

Insulation length **L** in mm

Number of conductors: **N**

Processing form: **A or D**

Pitch **P** in mm

Flat Flexible **Cable**

## 0.50, 1.00 and 1.25 mm pitch Flat Flexible Cables 100 micron conductors

### Standard versions

#### General characteristics

Temperature rating: up to 105°C.

Voltage rating: up to 60V AC.

#### Conductor

Pitch (mm)	Width (mm)	Max conductor resistance ( $\Omega$ /km) at 20°C	Conductor thickness (mm)
0.50	0.30 $\pm$ 0.02	730	0.10 $\pm$ 0.015
1.00	0.70 $\pm$ 0.03	300	0.10 $\pm$ 0.015
1.25	0.80 $\pm$ 0.03	280	0.10 $\pm$ 0.015



0.50 MM PITCH STANDARD FLAT FLEXIBLE CABLE

#### Conductor plating

Tin	0.4 $\mu$ m mini
Gold	0.3 $\mu$ m Ni mini / 0.05 $\mu$ m Au



1.00 MM PUNCHED FLAT FLEXIBLE CABLE.

#### Insulation

Polyester insulation with flame retardant adhesive.

White colour.

### Connection schemes

#### With ZIF connectors

Reinforcement tape: Polyester K code.

Blue colour.



#### Hot bar soldering

Reinforcement tape: Polyimide H code.

Natural colour (amber).



#### Manual soldering

Code for the end: T.

F1 ; F2 = 2.50 mm.



## 0.50, 1.00 and 1.25 mm pitch Flat Flexible Cables 100 micron conductors

### General drawing

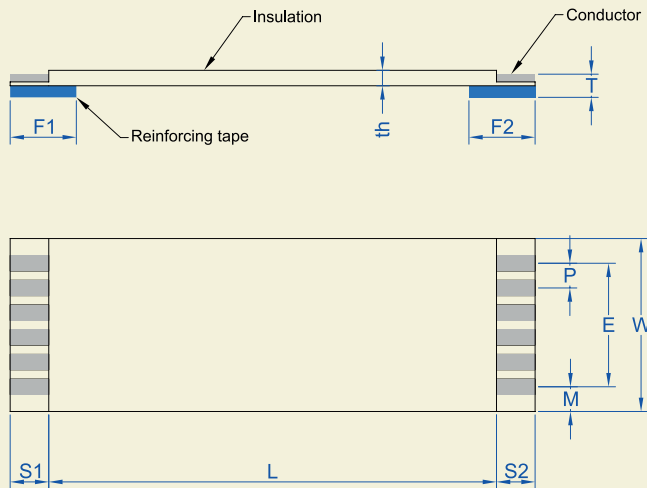

### Processing forms

#### Type A

Reinforcements at both ends,  
on the same side.

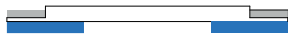

#### Type D

Reinforcements at both ends,  
on opposing side.

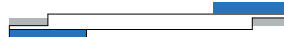

### Dimensions

Pitch: P (mm)	0.50 ± 0.05	1.00 ± 0.08	1.25 ± 0.10
Number of conductors: N	6 to 80	4 to 60	4 to 60
Span: E (mm)	(N-1)*0.50 ± 0.10	(N-1)*1.00 ± 0.15	(N-1)*1.25 ± 0.15
Width: W (mm)	(N+1)*0.50 ± 0.06	(N+1)*1.00 ± 0.10	(N+1)*1.25 ± 0.15
Margin: M (mm)	0.50 + 0.15/-0.096	1.00 ± 0.20	1.25 ± 0.20
Strip length: S1-S2 (mm)	2.00 to 10.0 ± 0.80 (standard value: 4 mm)		
Reinforcement length: F1-F2 (mm)	6.00 to 20.0 ± 2.00 (standard value: 8 mm)		
Insulated length: L (mm)	20 to 60 ± 2 61 to 100 ± 3 101 to 200 ± 4	201 to 3999 ± 5 4000 to 5999 ± 10 6000 to 9999 ± 15	
Thickness at end of cable: T (mm)	0.30 ± 0.05 (only for ZIF connectors)		
Cable thickness: th (mm)	0.25 typical		



## 0.50, 1.00 and 1.25 mm pitch Flat Flexible Cables 100 micron conductors

### Electrical properties

	Testing conditions	Pitch		
		0.50	1.00	1.25
Dielectric Test (V AC) - Min	Conductor to conductor, during 1 minute	200	400	500
Current rating (A) - Max	FFC at 23°C Allowable temperature rise: 40°C	0.55	1.25	1.40
Insulation resistance (M $\Omega$ .m min)	Conductor to conductor	10 at DC 200V	10 at DC 400V	10 at DC 500V
Continuity test	DC 3.0 V at 0.1mA	Passed	Passed	Passed
Impedance cond/cond balanced method (typical value)	FFC without shielding at 1MHz	130 $\Omega$	120 $\Omega$	130 $\Omega$
Capacitance cond/cond balanced method (typical value)	FFC without shielding at 1KHz	62 pF/m	50 pF/m	30 pF/m

### Other properties

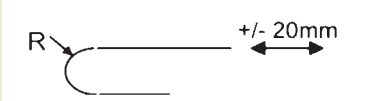
	Testing conditions	Characteristics	
Heat resistance	136°C, 168 hours	Dielectric test Insulation resistance	Passed Passed
Thermal shock	(-55°C x 30 min → 25°C x 5 min → 85°C x 30 min → 25°C x 5 min) x 25 cycles	Dielectric test Insulation resistance	Passed Passed
Cold coiling	-40°C, 96 hours The sample is initially wound on a mandrel of 3 mm	At room temperature: Visual inspection Dielectric test Insulation resistance	Passed Passed Passed
Wear by abrasion	Test following EN3475-503 Weight: 500 g Speed: 60 cycles/min Abrasion tool: $\varnothing = 0.50$ mm	Dielectric test Insulation resistance: After 10 000 cycles	Passed
Flame resistance	UL 758	VW-1	Passed
Solderability (tin plated conductors)	Immersion of the area which is intended for soldering into a tin bath at $250 \pm 10^\circ\text{C}$ During 30 seconds	No insulation separation Solder reflow below 1 mm	Passed Passed
Folding	The specimen shall be folded manually at 180°	Continuity after more than 20 times	Passed
Moisture resistance	60°C, 95% RH, 96 hours	Dielectric test Insulation resistance	Passed Passed
Flex-life (typical values)	speed 100 cycles /min Flex-life tests are performed at 23°C. 	Radius 10 mm	100 000 cycles

*0.50, 1.00 and 1.25 mm pitch Flat Flexible Cables  
100 micron conductors*



└ 0.50 MM PITCH GOLD PLATED FLAT FLEXIBLE CABLE

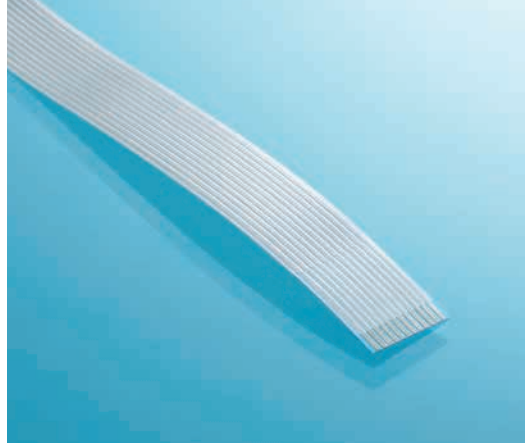

└ 1.25 MM PITCH FLAT FLEXIBLE CABLE

## UL compliance

With code A: the products are UL compliant.

With code B: the products are UL certified style 20706 and shipped with UL labels.

Temperature rating: 105°C; Voltage rating: 60V AC.

AXON'Cable UL file number: E45046.



Marking definition on the cable:

FFC with L > 30 mm and W > 9mm will have black printing on one side with the following text:

"AXON'CABLE –  – AWM – STYLE 20706 – 105C – 60V – VW-1"

## Special designs

Special designs available on request, such as specific shapes for connectors with locking systems.

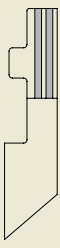
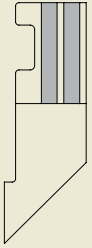
Pitch: P (mm)	0.50	0.50	0.50	0.50	1.00
FFC Drawing					

0.50, 1.00 and 1.25 mm pitch Flat Flexible Cables  
100 micron conductors

## Identification code

**FFC 1.00 A 25/0200 B 4.0-4.0-08.0-08.0 S A KK/AU**

### Options:

Plating on conductors  
-: tin plating  
**AU**: gold plating

### Reinforcement type (F1 & F2):

**K**: Polyester reinforcement  
**H**: Polyimide reinforcement  
**T**: Manual soldering

### UL compliance:

**A**: Without UL marking  
**B**: UL certified 20706

### Conductor thickness: s

(100 microns)

Reinforcement **length F2** in mm  
(8 mm standard length)

Reinforcement **length F1** in mm  
(8 mm standard length)

Strip **length S2** in mm (4 mm standard length)

Strip **length S1** in mm (4 mm standard length)

Insulation: **B**

Insulation length **L** in mm

Number of conductors: **N**

Processing form: **A or D**

Pitch **P** in mm

Flat Flexible **Cable**

# 0.50, 1.00 and 1.25 mm pitch Flat Flexible Cables 50 and 35 micron conductors

## Flexible and extra-flexible versions

### General characteristics

Temperature rating: up to 105°C.

Voltage rating: up to 60V AC.

### Conductor

Pitch (mm)	Width (mm)	Max Conductor Resistance ( $\Omega$ /km) at 20°C	
		Flexible (50 $\mu$ m)	Extra flexible (35 $\mu$ m)
0.50	0.30 $\pm$ 0.02	1460	2200
1.00	0.70 $\pm$ 0.03	550	790
1.25	0.80 $\pm$ 0.03	480	710
Conductor thickness (typical value)		0.05 mm	0.035 mm

### Conductor plating

Tin	0.4 $\mu$ m min
Gold	0.3 $\mu$ m Ni min / 0.05 $\mu$ m Au

### Insulation

Polyester insulation with flame retardant adhesive.

White colour.

### Connection schemes

#### With ZIF connectors

Reinforcement tape: Polyester B code.

Blue colour.



#### Hot bar soldering

Reinforcement tape: Polyimide H code.

Natural colour (amber).



## 0.50, 1.00 and 1.25 mm pitch Flat Flexible Cables 50 and 35 micron conductors

### General drawing

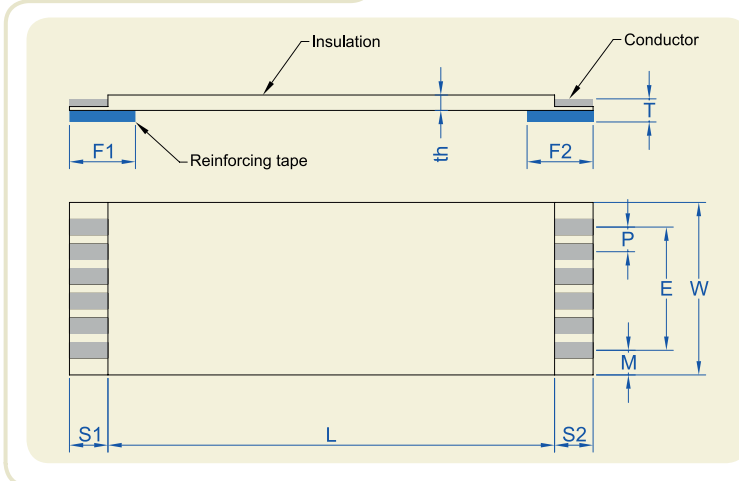

### Processing forms

#### Type A

Reinforcements at both ends,  
on the same side.

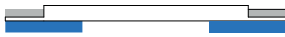

#### Type D

Reinforcements at both ends,  
on opposing side.

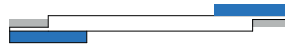

### Dimensions

Pitch: P (mm)	0.50 ± 0.05	1.00 ± 0.08	1.25 ± 0.10
Number of conductors: N	6 to 80	4 to 60	4 to 60
Span: E (mm)	$(N-1) \cdot 0.50 \pm 0.10$	$(N-1) \cdot 1.00 \pm 0.15$	$(N-1) \cdot 1.25 \pm 0.15$
Width: W (mm)	$(N+1) \cdot 0.50 \pm 0.06$	$(N+1) \cdot 1.00 \pm 0.10$	$(N+1) \cdot 1.25 \pm 0.15$
Margin: M (mm)	0.5 +0.15/-0.096	1.00 ± 0.20	1.25 ± 0.20
Strip length: S1-S2 (mm)	2.00 to 10.0 ± 0.80 (standard value: 4 mm)		
Reinforcement length: F1-F2 (mm)	6.00 to 20.0 ± 2.00 (standard value: 8 mm)		
Insulated length: L (mm)	20 to 60 ± 2 61 to 100 ± 3 101 to 200 ± 4		201 to 3999 ± 5 4000 to 5999 ± 10 6000 to 9999 ± 15
Thickness at end of cable: T (mm)	0.30 ± 0.05 (only for ZIF connectors)		
Cable thickness: th (mm)	Flexible: 0.14 / Extra flexible: 0.12 (typical value)		

## 0.50, 1.00 and 1.25 mm pitch Flat Flexible Cables 50 and 35 micron conductors

### Electrical properties

	Testing conditions	Pitch		
		0.50	1.00	1.25
Dielectric Test (V AC) - Min	Conductor to conductor, during 1 minute	200	400	500
Current rating (A) - Max Flexible conductor	FFC at 23°C Allowable temperature rise : 40°C	0.40	0.80	0.85
Current rating (A) - Max Extra flexible conductor		0.35	0.80	0.80
Insulation resistance (MΩ.m min)	Conductor to conductor	10 at DC 200V	10 at DC 400V	10 at DC 500V
Continuity test	DC 3.0 V at 0.1mA	Passed	Passed	Passed
Impedance cond/cond balanced method (typical value)	FFC without shielding at 1MHz	150 Ω	150 Ω	170 Ω
Capacitance cond/cond balanced method (typical value)	FFC without shielding at 1KHz	50 pF/m	40 pF/m	35 pF/m

### Other properties

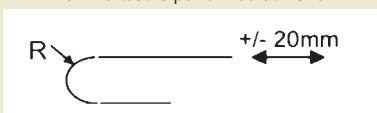
	Testing conditions	Characteristics		
Heat resistance	136°C, 168 hours	Dielectric test Insulation resistance	Passed Passed	
Thermal shock	(-55°C x 30 min → 25°C x 5 min → 85°C x 30 min → 25°C x 5 min) x 25 cycles	Dielectric test Insulation resistance	Passed Passed	
Cold coiling	-40°C, 96 hours The sample is initially wound on a mandrel of 3 mm	At room temperature: Visual inspection Dielectric test Insulation resistance	Passed Passed Passed	
Wear by abrasion	Test following EN3475-503 Weight: 500 g Speed: 60 cycles/min Abrasion tool: Ø = 0.50 mm	Dielectric test Insulation resistance: After 500 cycles	Passed	
Flame resistance	UL 758	VW-1	Passed	
Solderability (tin plated conductors)	Immersion of the area which is intended for soldering into a tin bath at 250 ± 10°C During 30 seconds	No insulation separation Solder reflow below 1 mm	Passed Passed	
Folding	The specimen shall be folded manually at 180°	Continuity after more than 20 times	Passed	
Moisture resistance	60°C, 95% RH, 96 hours	Dielectric test Insulation resistance	Passed Passed	
Flex-life Number of cycles (typical values)	Speed 100 cycles /min Flex-life test is performed at 23°C. 	Radius	5 mm	10 mm
		Flexible	20 000	2 500 000
		Extra flexible	100 000	5 000 000

*0.50, 1.00 and 1.25 mm pitch Flat Flexible Cables  
50 and 35 micron conductors*



0.50 MM PITCH STANDARD FLAT FLEXIBLE CABLE



0.50 MM PITCH PUNCHED FLAT FLEXIBLE CABLE

## UL compliance

With code A: the products are UL compliant.

With code B: the products are UL certified style 20706 and shipped with UL labels.

Temperature rating: 105°C; Voltage rating: 60V AC.

AXON'Cable UL file number: E45046.



Marking definition on the cable:

FFC with L > 30 mm and W > 9mm will have black printing on one side with the following text:

"AXON'CABLE –  – AWM – STYLE 20706 – 105C – 60V – VW-1"

## Special designs

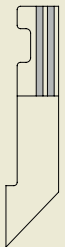
Special designs available on request, such as specific shapes for connectors with locking systems.

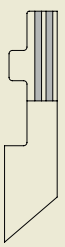
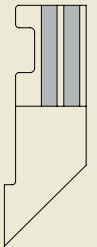
Pitch: P (mm)	0.50	0.50	0.50	0.50	1.00
FFC Drawing					

*0.50, 1.00 and 1.25 mm pitch Flat Flexible Cables  
50 and 35 micron conductors*

## Identification code

**FFC 1.00 A 25/0200 E 4.0-4.0-08.0-08.0 F A BB/AU**

**Options:**

Plating on conductors  
-: tin plating  
**AU:** gold plating

**Reinforcement type (F1 & F2):**

**B:** Polyester reinforcement

**UL compliance:**

**A:** Without UL marking  
**B:** UL certified 20706

**Conductor thickness:**

**F:** Flexible (50 microns)  
**E:** Extra flexible (35 microns)

Reinforcement **length F2** in mm  
(8 mm standard length)

Reinforcement **length F1** in mm  
(8 mm standard length)

Strip **length S2** in mm (4 mm standard length)

Strip **length S1** in mm (4 mm standard length)

Insulation: **E**

Insulation length **L** in mm

Number of conductors: **N**

Processing form: **A or D**

Pitch **P** in mm

**Flat Flexible Cable**



## 1.00 and 1.25 mm pitch Flat Flexible Cables 25 micron conductors

### Ultra-flexible versions

#### General characteristics

Temperature rating: up to 105°C.

Voltage rating: up to 60V AC.

#### Conductor

Pitch (mm)	Width (mm)	Max Conductor Resistance ( $\Omega$ /km) at 20°C
		Ultra Flexible (25 $\mu$ m)
1.00	0.60 $\pm$ 0.03	1500
1.25	0.80 $\pm$ 0.03	970
Conductor thickness (typical value)		0.025 mm

#### Conductor plating

Tin	0.4 $\mu$ m min
Gold	0.3 $\mu$ m Ni min / 0.05 $\mu$ m Au

#### Insulation

Polyester insulation with flame retardant adhesive. White colour.

#### Connection schemes

##### With ZIF connectors

Reinforcement tape: Polyester B code.  
Blue colour.



#### General drawing

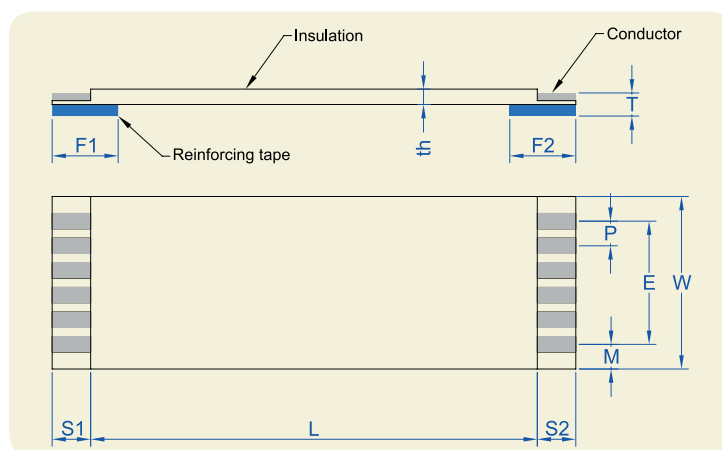

## 1.00 and 1.25 mm pitch Flat Flexible Cables 25 micron conductors

### Processing forms

#### Type A

Reinforcements at both ends,  
on the same side.

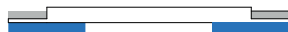

#### Type D

Reinforcements at both ends,  
on opposing side.

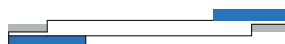

### Dimensions

Pitch: P (mm)	1.00 ± 0.08	1.25 ± 0.10
Number of conductors: N	4 to 60	4 to 60
Span: E (mm)	(N-1)*1.00 ± 0.15	(N-1)*1.25 ± 0.15
Width: W (mm)	(N+1)*1.00 ± 0.10	(N+1)*1.25 ± 0.15
Margin: M (mm)	1.00 ± 0.20	1.25 ± 0.20
Strip length: S1-S2 (mm)	2.00 to 10.0 ± 0.80 (standard value: 4 mm)	
Reinforcement length: F1-F2 (mm)	6.00 to 20.0 ± 2.00 (standard value: 8 mm)	
Insulated length: L (mm)	20 to 60 ± 2 61 to 100 ± 3 101 to 200 ± 4	201 to 3999 ± 5 4000 to 5999 ± 10 6000 to 9999 ± 15
Thickness at end of cable: T (mm)	0.30 ± 0.05 (only for ZIF connectors)	
Cable thickness: th (mm)	0.11 (typical value)	

### Electrical properties

	Testing conditions	Pitch	
		1.00	1.25
Dielectric Test (V AC) - Min	In air, during 1 minute	400	500
Current rating (A) - Max Ultra Flexible conductor	FFC at 23°C Allowable temperature rise : 40°C	0.5	0.6
Insulation resistance conductor to conductor (MΩ.m min)		10 at DC 400V	10 at DC 500V
Continuity test	DC 3.0 V at 0.1mA	Passed	Passed
Impedance cond/cond balanced method (typical value)	FFC without shielding at 1MHz	90 Ω	90 Ω
Capacitance cond/cond balanced method (typical value)	FFC without shielding at 1KHz	30 pF/m	25 pF/m

## 1.00 and 1.25 mm pitch Flat Flexible Cables 25 micron conductors

### Other properties

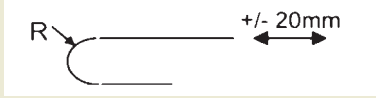
	Testing conditions	Characteristics	
Heat resistance	136°C, 168 hours	Dielectric test Insulation resistance	Passed Passed
Thermal shock	(-55°C x 30 min → 25°C x 5 min → 85°C x 30 min → 25°C x 5 min) x 25 cycles	Dielectric test Insulation resistance	Passed Passed
Cold coiling	-40°C, 96 hours The sample is initially wound on a mandrel of 3 mm	At room temperature: Visual inspection Dielectric test Insulation resistance	Passed Passed Passed
Wear by abrasion	Test following EN3475-503 Weight: 500 g Speed: 60 cycles/min Abrasion tool: Ø = 0.50 mm	Dielectric test Insulation resistance: After 500 cycles	Passed
Flame resistance	UL 758	VW-1	Passed
Solderability (tin plated conductors)	Immersion of the area which is intended for soldering into a tin bath at 250 ± 10°C During 30 seconds	No insulation separation Solder reflow below 1 mm	Passed Passed
Folding	The specimen shall be folded manually at 180°	Continuity after more than 20 times	Passed
Moisture resistance	60°C, 95% RH, 96 hours	Dielectric test Insulation resistance	Passed Passed
Flex-life Number of cycles (typical values)	Speed 100 cycles /min Flex-life test is performed at 23°C. 	Radius	5 mm      10 mm
		Ultra flexible	10 000 000      70 000 000



FLEX LIFE TEST



ULTRA-FLEXIBLE FLAT CABLE

### UL compliance

With code A: the products are UL compliant.

With code B: the products are UL certified style 20706 and shipped with UL labels.

Temperature rating: 105°C; Voltage rating: 60V AC.

AXON'Cable UL file number: E45046.

Marking definition on the cable:

FFC with L > 30 mm and W > 9mm will have black printing on one side with the following text:

"AXON'CABLE –  – AWM – STYLE 20706 – 105C – 60V – VW-1"

## 1.00 and 1.25 mm pitch Flat Flexible Cables 25 micron conductors

### Identification code

**FFC 1.00 A 25/0200 E 4.0-4.0-08.0-08.0 U A BB/AU**

#### Options:

Plating on conductors  
-: tin plating  
**AU:** gold plating

#### Reinforcement type (F1 & F2):

**B:** Polyester reinforcement

#### UL compliance:

**A:** Without UL marking  
**B:** UL certified 20706

#### Conductor thickness:

**U:** Ultra Flexible (25 microns)

Reinforcement **length F2** in mm  
(8 mm standard length)

Reinforcement **length F1** in mm  
(8 mm standard length)

Strip **length S2** in mm (4 mm standard length)

Strip **length S1** in mm (4 mm standard length)

Insulation: **E**

Insulation length **L** in mm

Number of conductors: **N**

Processing form: **A or D**

Pitch **P** in mm

Flat Flexible **Cable**

## Shielded Flat Flexible Cables

### General characteristics

Temperature rating: up to 105°C.

Voltage rating: up to 60 V AC.

### Conductor

Pitch (mm)	Width (mm)	Max Conductor Resistance ( $\Omega$ /km) at 20°C
0.50	0.30 ± 0.02	1460
1.00	0.70 ± 0.03	550
Conductor thickness (Typical value)		0.05 mm

### Conductor plating

Tin	0.4 $\mu$ m min
Gold	0.3 $\mu$ m Ni min / 0.05 $\mu$ m Au

### Insulation

Polyester insulation with flame retardant adhesive.

White colour.

### Shielding

Aluminium tape with Polyester insulation  
Grey colour

Shielding is possible on flat cables with:  
- a width W of 3.5 to 40 mm and a length L of 70 to 300 mm,  
> For other dimensions (Please contact us for further information).

> Version S

Aluminium shielded version without grounding.

> Version G + grounded tracks (for example G2-5)

Aluminium shielded version with grounding (no limit for the number of grounds).

### Connection scheme

#### With ZIF connectors

Polyester reinforcement tape.

Blue colour.



## Shielded Flat Flexible Cables

### General drawing

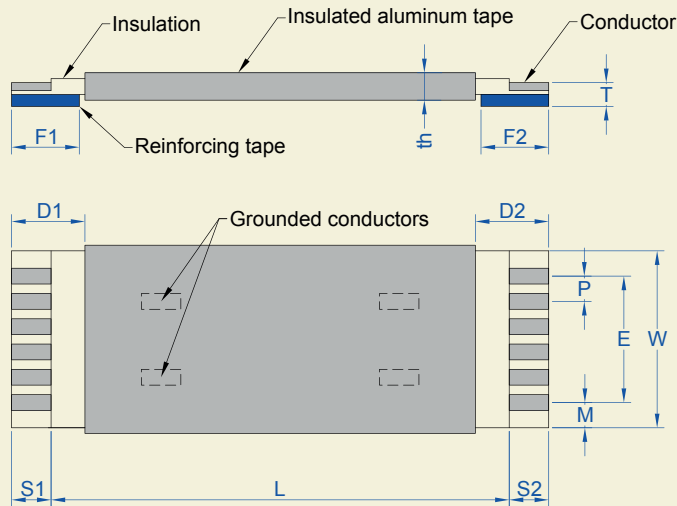

### Processing forms

#### Type A

Reinforcements at both ends,  
on the same side.



#### Type D

Reinforcements at both ends,  
on opposing side.

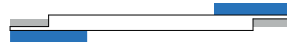

### Dimensions

Pitch: P (mm)	0.50 ± 0.05	1.00 ± 0.08
Number of conductors: N	6 to 80	4 to 60
Span: E (mm)	$(N-1) \cdot 0.50 \pm 0.10$	$(N-1) \cdot 1.00 \pm 0.15$
Width: W (mm)	$(N+1) \cdot 0.50 \pm 0.10$	$(N+1) \cdot 1.00 \pm 0.10$
Margin: M (mm)	$0.50 + 0.15 / - 0.096$	$1.00 \pm 0.20$
Strip length: S1-S2 (mm)	2.00 to 10.0 ± 0.80 (standard value: 4 mm)	
Reinforcement length: F1-F2 (mm)	6.00 to 20.0 ± 2.00 (standard value: 8 mm)	
Shielding position: D1-D2(mm)	$(F1 \text{ or } F2 \text{ max} + 1) \pm 3$	
Insulated length: L (mm)	70 to 100 ± 3 101 to 200 ± 4 201 to 300 ± 5	
Thickness at end of cable: T (mm)	0.30 ± 0.05	
Cable thickness: th (mm)	0.22 (typical value)	0.28 (typical value)

## Shielded Flat Flexible Cables

## Electrical properties

	Testing conditions	Pitch	
		0.50	1.00
Dielectric Test (V AC) - Min	Conductor to conductor, during 1 minute	200	400
Current rating (A) - Max FFC at 23°C Allowable temperature rise: 40°C	Flexible conductor	0.50	1.00
Insulation resistance (MΩ.m min)	Conductor to conductor	10 at DC 200V	10 at DC 400V
Continuity test	DC 3.0 V at 0.1mA	Passed	Passed
Impedance cond/cond balanced method (typical value)	FFC with shielding at 1 KHz	67 Ω	60 Ω
Impedance cond/shielding (typical value)	FFC with shielding at 1 KHz	45 Ω	40 Ω
Capacitance cond/cond balanced method (typical value)	FFC with shielding at 1 KHz	230 pF/m	220 pF/m
Capacitance cond / shielding (typical value)	FFC with shielding at 1 KHz	470 pF/m	500 pF/m

## Other properties

	Testing conditions	Characteristics	
Heat resistance	113°C, 168 hours	Dielectric test Insulation resistance	Passed Passed
Thermal shock	(-55°C x 30 min → 25°C x 5 min → 85°C x 30 min → 25°C x 5 min) x 25 cycles	Dielectric test Insulation resistance	Passed Passed
Cold coiling	-40°C, 96 hours The sample is initially wound on a mandrel of 3 mm	At room temperature: Visual inspection Dielectric test Insulation resistance	Passed Passed Passed
Wear by Abrasion	Test following EN3475-503 Weight: 500 g Speed: 60 cycles/min Abrasion tool: Ø = 0.50 mm	Dielectric test Insulation resistance: after 500 cycles	Passed
Flame resistance	UL 758	VW-1	Passed
Solderability (tin plated conductors)	Immersion of the area which is intended for soldering into a tin bath at 250 ± 10°C During 30 seconds	No insulation separation Solder reflow below 1 mm	Passed Passed
Folding	The specimen shall be folded manually at 180°	Continuity after more than 20 times	Passed
Moisture resistance	60°C, 95% RH, 96 hours	Dielectric test Insulation resistance	Passed Passed
Flex-life Number of cycles (typical values)	Speed 100 cycles /min Flex-life test is performed at 23°C. 	Radius 10 mm	100 000 cycles

## Shielded Flat Flexible Cables

### UL compliance

UL compliance only for shielded FFC **without grounding**.

With code A: the products are UL compliant.

With code B: the products are UL certified style 20706 and shipped with UL labels.

Temperature rating: 105°C; Voltage rating: 60V AC.

AXON'Cable UL file number: E45046.

Marking definition on the cable:

FFC with  $L > 30$  mm and  $W > 9$ mm will have black printing on one side with the following text:

"AXON'CABLE –  – AWM – STYLE 20706 – 105C – 60V – VW-1"



SHIELDED FLAT FLEXIBLE CABLES



## Shielded Flat Flexible Cables

## Identification code

FFC 0.50 A 50 / 0200 E 4.0 - 4.0 - 08.0 - 08.0 F A BB / AU / G2 - 5

**Shielding:****S:** Aluminium shielding without grounding**G:** Grounded Aluminium shielding + n° of grounded conductors**Options:**

Plating on conductors

-: tin plating

**AU:** gold plating**Reinforcement type (F1 & F2):****B** (for pitch of 0.5mm)**J** (for pitch of 1mm)**UL compliance:****A:** Without UL marking**B:** UL certified 20706**Conductor thickness:****F:** Flexible (50 microns)Reinforcement **length F2** in mm  
(8 mm standard length)Reinforcement **length F1** in mm  
(8 mm standard length)Strip **length S2** in mm (4 mm standard length)Strip **length S1** in mm (4 mm standard length)**Insulation:****E** (for pitch of 0.5mm)**B** (for pitch of 1mm)Insulation length **L** in mmNumber of conductors: **N**Processing form: **A or D**Pitch **P** in mm**Flat Flexible Cable**

>> BRAZIL

**AXON' CABLE INDUSTRIA E COMÉRCIO LTDA**

Av. Afonso Arinos de Melo Franco  
222 sala 276 bloco 2b  
Barra da Tijuca - CEP.: 22631-455  
RIO DE JANEIRO-RJ  
TEL.: +55 21 3596-8002  
e-mail: l.moreira@axon-cable.com

>> CANADA

**AXON' CABLE CANADIAN OFFICE**

4578 rue Chabot  
H2H 1Y3 MONTREAL, QUEBEC  
TEL.: +1 514 898 2044  
e-mail: g.hannequin@axoncable.com

>> CHINA

**AXON' INTERCONNECT LTD**

High Tech Industrial Park,  
Chang Bao XI Road  
Ronggui, 528306  
SHUNDE, GUANGDONG  
TEL.: +86 757 2838 7200  
FAX: +86 757 2838 7212  
e-mail: sales@axon-interconnect.com

>> GERMANY

**AXON' KABEL GMBH**

Postfach 1131 - 71201 LEONBERG  
Hertichstr. 43 - 71229 LEONBERG  
TEL.: +49 7152-97992-0  
FAX: +49 7152-97992-7  
e-mail: sales@axon-cable.de

>> HUNGARY

**AXON' KÁBELGYÁRTÓ KFT.**

KÜLSŐ-SZEGEDI ÚT 104.  
H-6000 KECSKEMÉT,  
TEL.: +36 76 508 195  
FAX: +36 76 508 196  
e-mail: axon@axon-cable.hu

>> INDIA

**AXON' INTERCONNECTORS AND WIRES PVT LTD**

#117, Neil Rao Towers, Suite No. 1W,  
Road No. 3 EPIP, Whitefield  
BANGALORE - 560 066  
TEL.: +91 80 40918186  
FAX: +91 80 40918185  
e-mail: sales@axon-cable.in

>> JAPAN

**AXON' CABLE JAPAN OFFICE**

TEL./FAX: +81 26 244 2261  
e-mail: axon-japan@axon-cable.com

>> LATVIA

**AXON' CABLE SIA**

Višku Iela, 21 C - LV-5410 DAUGAVPILS  
TEL.: +371 6540 78 91  
FAX: +371 6540 78 93  
e-mail: axon@axoncable.lv

>> MEXICO

**AXON' INTERCONEX, S.A. DE C.V.**

Av. Peñuelas 21-A1.  
Industrial San Pedrito Peñuelas  
Querétaro Park  
76148 Querétaro, Qro.  
TEL: +52 442 215 2713  
FAX: +52 442 220 6464  
e-mail: axon-mexico@axoncable.com

>> SPAIN

**AXON' CABLE SPANISH OFFICE**

C/Capitán Haya, N°1, Planta 15  
28020 MADRID  
TEL.: +34 91 418 43 46  
FAX: +34 91 556 28 80  
e-mail: sales@axon-cable.com

>> UNITED KINGDOM

**AXON' CABLE LTD**

**AXON' AGORA**

Admiralty Park - ROSYTH DUNFERMLINE  
FIFE KY11 2YW  
TEL.: +44 1383 421500  
FAX: +44 8715 282789  
e-mail: sales@axon-cable.co.uk

>> USA

**AXON' CABLE INC.**

1314 N Plum Grove Road  
SCHAUMBURG, IL. 60173  
TEL.: +1 847 230 7800  
FAX: +1 847 230 7849  
e-mail: sales@axoncable.com

HEADQUARTERS

>> France

VISIT OUR WEBSITE  
[www.axon-cable.com](http://www.axon-cable.com)



FOLLOW US



**axon'**  
cable & interconnect

>> AXON' CABLE S.A.S.

2 ROUTE DE CHALONS EN CHAMPAGNE - 51210 MONTMIRAIL  
TEL : +33 3 26 81 70 00 - FAX : +33 3 26 81 28 83  
e-mail : sales@axon-cable.com - <http://www.axon-cable.com>