



www.robotshop.com



La robotique à votre service! - Robotics at your service!



Arduino Mega 2560 Datasheet

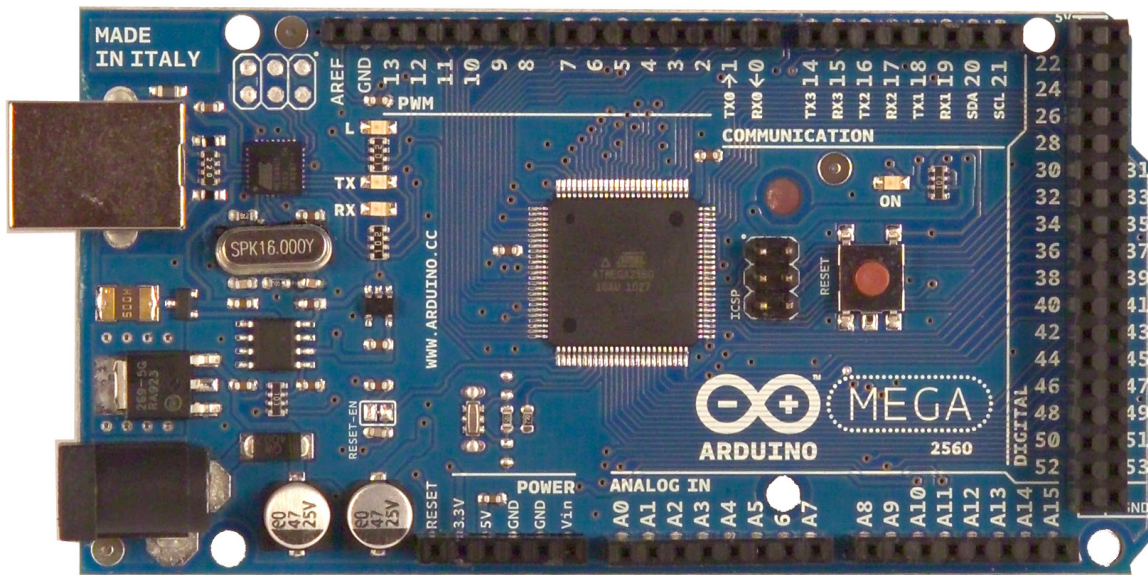



www.robotshop.com



La robotique à votre service! - Robotics at your service!

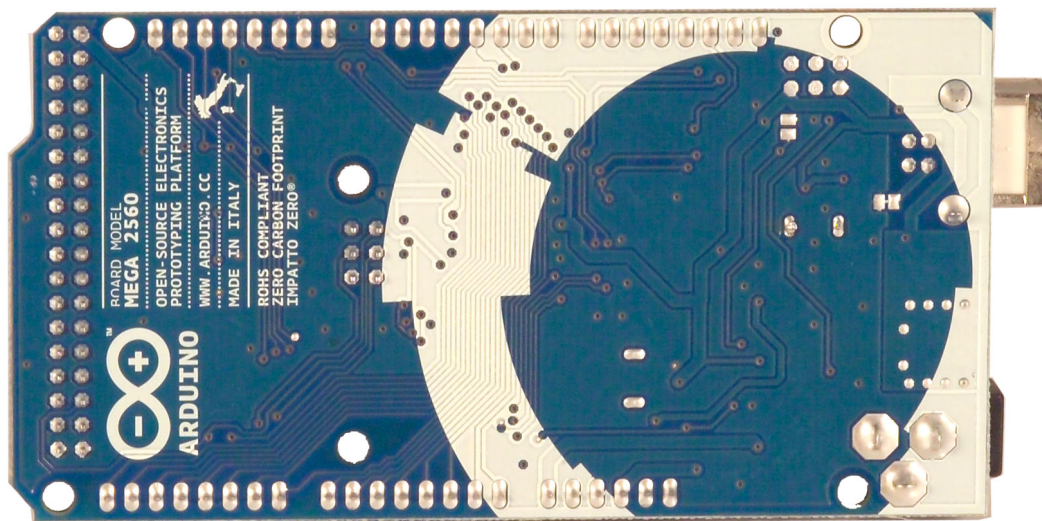

Overview

The Arduino Mega 2560 is a microcontroller board based on the ATmega2560 ([datasheet](#)). It has 54 digital input/output pins (of which 14 can be used as PWM outputs), 16 analog inputs, 4 UARTs (hardware serial ports), a 16 MHz crystal oscillator, a USB connection, a power jack, an ICSP header, and a reset button. It contains everything needed to support the microcontroller; simply connect it to a computer with a USB cable or power it with a AC-to-DC adapter or battery to get started. The Mega is compatible with most shields designed for the Arduino Duemilanove or Diecimila.

Schematic & Reference Design

EAGLE files: [arduino-mega2560-reference-design.zip](#)

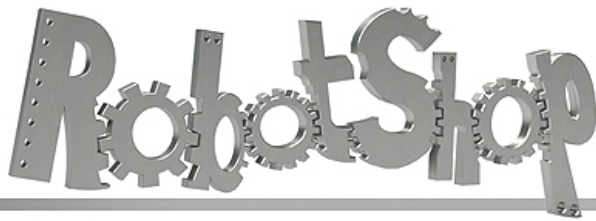

www.robotshop.com



La robotique à votre service! - Robotics at your service!

Schematic: [arduino-mega2560-schematic.pdf](#)

Summary

Microcontroller	ATmega2560
Operating Voltage	5V
Input Voltage (recommended)	7-12V
Input Voltage (limits)	6-20V
Digital I/O Pins	54 (of which 14 provide PWM output)
Analog Input Pins	16
DC Current per I/O Pin	40 mA
DC Current for 3.3V Pin	50 mA
Flash Memory	256 KB of which 8 KB used by bootloader
SRAM	8 KB
EEPROM	4 KB
Clock Speed	16 MHz

Power

The Arduino Mega can be powered via the USB connection or with an external power supply. The power source is selected automatically.

External (non-USB) power can come either from an AC-to-DC adapter (wall-wart) or battery. The adapter can be connected by plugging a 2.1mm center-positive plug into the board's power jack. Leads from a battery can be inserted in the Gnd and Vin pin headers of the POWER connector.

The board can operate on an external supply of 6 to 20 volts. If supplied with less than 7V, however, the 5V pin may supply less than five volts and the board may be unstable. If using more than 12V, the voltage regulator may overheat and damage the board. The recommended range is 7 to 12 volts.

The Mega2560 differs from all preceding boards in that it does not use the FTDI USB-to-serial driver chip. Instead, it features the Atmega8U2 programmed as a USB-to-serial converter.



www.robotshop.com



La robotique à votre service! - Robotics at your service!

The power pins are as follows:

- **VIN.** The input voltage to the Arduino board when it's using an external power source (as opposed to 5 volts from the USB connection or other regulated power source). You can supply voltage through this pin, or, if supplying voltage via the power jack, access it through this pin.
- **5V.** The regulated power supply used to power the microcontroller and other components on the board. This can come either from VIN via an on-board regulator, or be supplied by USB or another regulated 5V supply.
- **3V3.** A 3.3 volt supply generated by the on-board regulator. Maximum current draw is 50 mA.
- **GND.** Ground pins.

Memory

The ATmega2560 has 256 KB of flash memory for storing code (of which 8 KB is used for the bootloader), 8 KB of SRAM and 4 KB of EEPROM (which can be read and written with the [EEPROM library](#)).

Input and Output

Each of the 54 digital pins on the Mega can be used as an input or output, using [pinMode\(\)](#), [digitalWrite\(\)](#), and [digitalRead\(\)](#) functions. They operate at 5 volts. Each pin can provide or receive a maximum of 40 mA and has an internal pull-up resistor (disconnected by default) of 20-50 kOhms. In addition, some pins have specialized functions:

- **Serial: 0 (RX) and 1 (TX); Serial 1: 19 (RX) and 18 (TX); Serial 2: 17 (RX) and 16 (TX); Serial 3: 15 (RX) and 14 (TX).** Used to receive (RX) and transmit (TX) TTL serial data. Pins 0 and 1 are also connected to the corresponding pins of the ATmega8U2 USB-to-TTL Serial chip.
- **External Interrupts: 2 (interrupt 0), 3 (interrupt 1), 18 (interrupt 5), 19 (interrupt 4), 20 (interrupt 3), and 21 (interrupt 2).** These pins can be configured to trigger an interrupt on a low value, a rising or falling edge, or a change in value. See the [attachInterrupt\(\)](#) function for details.
- **PWM: 0 to 13.** Provide 8-bit PWM output with the [analogWrite\(\)](#) function.
- **SPI: 50 (MISO), 51 (MOSI), 52 (SCK), 53 (SS).** These pins support SPI communication using the [SPI library](#). The SPI pins are also broken out on the ICSP header, which is physically compatible with the Uno, Duemilanove and Diecimila.
- **LED: 13.** There is a built-in LED connected to digital pin 13. When the pin is HIGH



www.robotshop.com



La robotique à votre service! - Robotics at your service!

value, the LED is on, when the pin is LOW, it's off.

- **I²C: 20 (SDA) and 21 (SCL).** Support I²C (TWI) communication using the [Wire library](#) (documentation on the Wiring website). Note that these pins are not in the same location as the I²C pins on the Duemilanove or Diecimila.

The Mega2560 has 16 analog inputs, each of which provide 10 bits of resolution (i.e. 1024 different values). By default they measure from ground to 5 volts, though it is possible to change the upper end of their range using the AREF pin and `analogReference()` function.

There are a couple of other pins on the board:

- **AREF.** Reference voltage for the analog inputs. Used with [analogReference\(\)](#).
- **Reset.** Bring this line LOW to reset the microcontroller. Typically used to add a reset button to shields which block the one on the board.

Communication

The Arduino Mega2560 has a number of facilities for communicating with a computer, another Arduino, or other microcontrollers. The ATmega2560 provides four hardware UARTs for TTL (5V) serial communication. An ATmega8U2 on the board channels one of these over USB and provides a virtual com port to software on the computer (Windows machines will need a .inf file, but OSX and Linux machines will recognize the board as a COM port automatically). The Arduino software includes a serial monitor which allows simple textual data to be sent to and from the board. The RX and TX LEDs on the board will flash when data is being transmitted via the ATmega8U2 chip and USB connection to the computer (but not for serial communication on pins 0 and 1).

A [SoftwareSerial library](#) allows for serial communication on any of the Mega2560's digital pins.

The ATmega2560 also supports I²C (TWI) and SPI communication. The Arduino software includes a `Wire` library to simplify use of the I²C bus; see the [documentation on the Wiring website](#) for details. For SPI communication, use the [SPI library](#).

Programming

The Arduino Mega can be programmed with the Arduino software ([download](#)). For details, see the [reference](#) and [tutorials](#).

The ATmega2560 on the Arduino Mega comes preburned with a [bootloader](#) that allows you to upload new code to it without the use of an external hardware programmer. It



www.robotshop.com



La robotique à votre service! - Robotics at your service!

communicates using the original STK500 protocol ([reference](#), [C header files](#)). You can also bypass the bootloader and program the microcontroller through the ICSP (In-Circuit Serial Programming) header; see [these instructions](#) for details.

Automatic (Software) Reset

Rather than requiring a physical press of the reset button before an upload, the Arduino Mega2560 is designed in a way that allows it to be reset by software running on a connected computer. One of the hardware flow control lines (DTR) of the ATmega8U2 is connected to the reset line of the ATmega2560 via a 100 nanofarad capacitor. When this line is asserted (taken low), the reset line drops long enough to reset the chip. The Arduino software uses this capability to allow you to upload code by simply pressing the upload button in the Arduino environment. This means that the bootloader can have a shorter timeout, as the lowering of DTR can be well-coordinated with the start of the upload. This setup has other implications. When the Mega2560 is connected to either a computer running Mac OS X or Linux, it resets each time a connection is made to it from software (via USB). For the following half-second or so, the bootloader is running on the Mega2560. While it is programmed to ignore malformed data (i.e. anything besides an upload of new code), it will intercept the first few bytes of data sent to the board after a connection is opened. If a sketch running on the board receives one-time configuration or other data when it first starts, make sure that the software with which it communicates waits a second after opening the connection and before sending this data.

The Mega2560 contains a trace that can be cut to disable the auto-reset. The pads on either side of the trace can be soldered together to re-enable it. It's labeled "RESET-EN". You may also be able to disable the auto-reset by connecting a 110 ohm resistor from 5V to the reset line; see [this forum thread](#) for details.

USB Overcurrent Protection

The Arduino Mega2560 has a resettable polyfuse that protects your computer's USB ports from shorts and overcurrent. Although most computers provide their own internal protection, the fuse provides an extra layer of protection. If more than 500 mA is applied to the USB port, the fuse will automatically break the connection until the short or overload is removed.

Physical Characteristics and Shield Compatibility



www.robotshop.com



La robotique à votre service! - Robotics at your service!

The maximum length and width of the Mega2560 PCB are 4 and 2.1 inches respectively, with the USB connector and power jack extending beyond the former dimension. Three screw holes allow the board to be attached to a surface or case. Note that the distance between digital pins 7 and 8 is 160 mil (0.16"), not an even multiple of the 100 mil spacing of the other pins.

The Mega2560 is designed to be compatible with most shields designed for the Uno, Diecimila or Duemilanove. Digital pins 0 to 13 (and the adjacent AREF and GND pins), analog inputs 0 to 5, the power header, and ICSP header are all in equivalent locations. Further the main UART (serial port) is located on the same pins (0 and 1), as are external interrupts 0 and 1 (pins 2 and 3 respectively). SPI is available through the ICSP header on both the Mega2560 and Duemilanove / Diecimila. *Please note that I2C is not located on the same pins on the Mega (20 and 21) as the Duemilanove / Diecimila (analog inputs 4 and 5).*

ALPHANUMERIC LCD DISPLAY (16 x 2)

Order Code

LED008 16 x 2 Alphanumeric Display
FRM010 Serial LCD Firmware (optional)

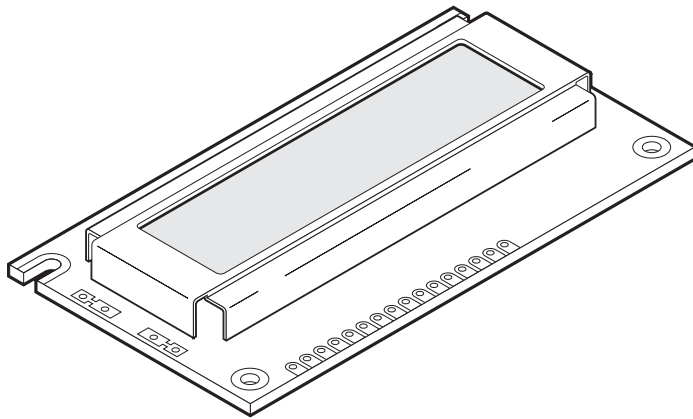

Contents

1 x 16x2 Alphanumeric Display
1 x data booklet

Introduction

Alphanumeric displays are used in a wide range of applications, including palmtop computers, word processors, photocopiers, point of sale terminals, medical instruments, cellular phones, etc. The 16 x 2 intelligent alphanumeric dot matrix display is capable of displaying 224 different characters and symbols. A full list of the characters and symbols is printed on pages 7/8 (note these symbols can vary between brand of LCD used). This booklet provides all the technical specifications for connecting the unit, which requires a single power supply (+5V).

Further Information

Available as an optional extra is the Serial LCD Firmware, which allows serial control of the display. This option provides much easier connection and use of the LCD module. The firmware enables microcontrollers (and microcontroller based systems such as the PICAXE) to visually output user instructions or readings onto an LCD module. All LCD commands are transmitted serially via a single microcontroller pin. The firmware can also be connected to the serial port of a computer.

An example PICAXE instruction to print the text 'Hello' using the `serout` command is as follows:

```
serout 7,T2400,("Hello")
```

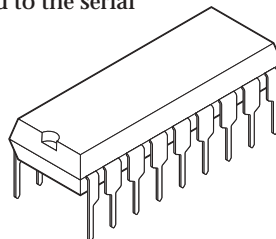

Outline Dimension and Block Diagram

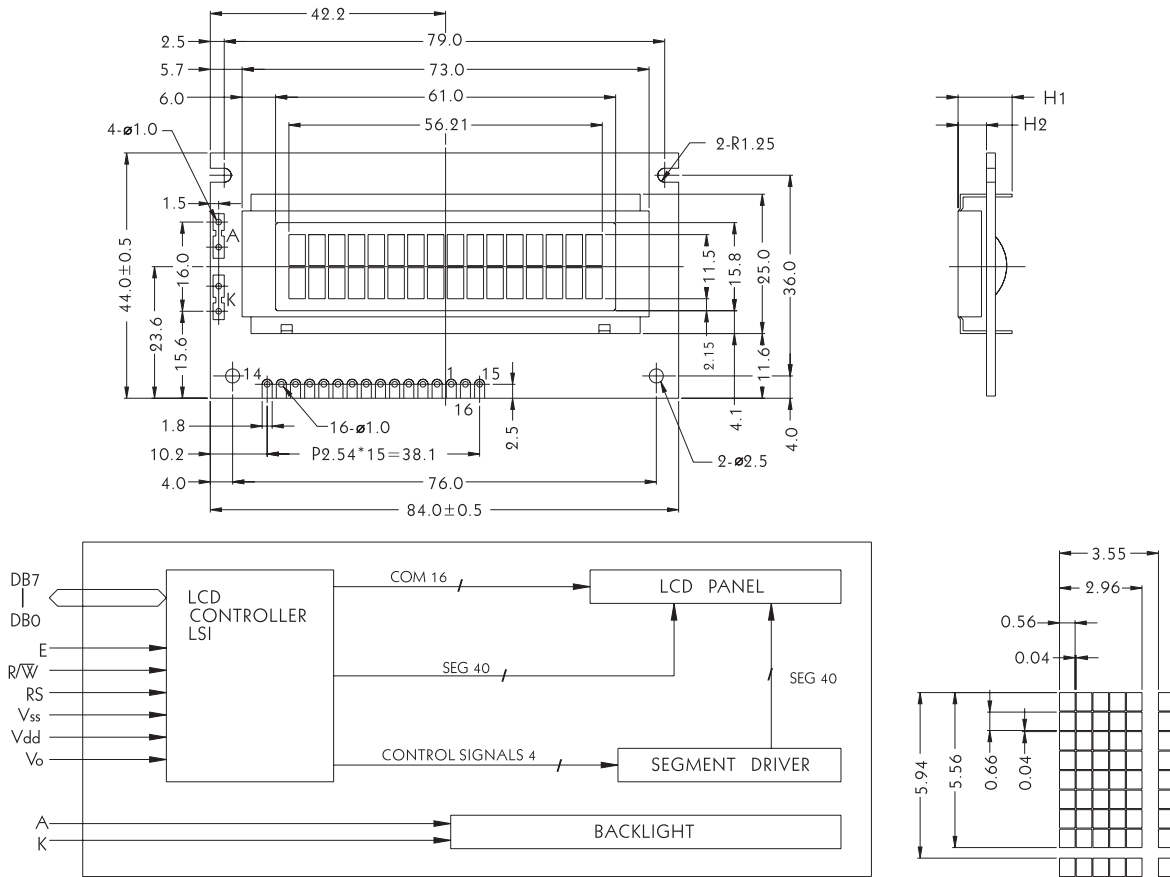

The tolerance unless classified $\pm 0.3\text{mm}$

MECHANICAL SPECIFICATION

Overall Size	84.0 * 44.0	Module	H2 / H1
View Area	61.0 * 15.8	W/O B/L	5.1 / 9.7
Dot Size	0.56 * 0.66	EL B/L	5.1 / 9.7
Dot Pitch	0.60 * 0.70	LED B/L	9.4 / 14.0

PIN ASSIGNMENT

Pin no.	Symbol	Function
1	V _{ss}	Power supply (GND)
2	V _{dd}	Power supply (+5V)
3	V ₀	Contrast Adjust
4	RS	Register select signal
5	R/W	Data read/write
6	E	Enable signal
7	DB0	Data bus line
8	DB1	Data bus line
9	DB2	Data bus line
10	DB3	Data bus line
11	DB4	Data bus line
12	DB5	Data bus line
13	DB6	Data bus line
14	DB7	Data bus line
15	A	Power supply for LED B/L (+)
16	K	Power supply for LED B/L (-)

ABSOLUTE MAXIMUM RATING

Item	Symbol	Conditions	Min.	Max.	Unit
Power Supply Voltage	V _{dd} -V _{ss}	—	0	7	V
LCD Driving Supply Voltage	V _{dd} -V _{ee}	—	0	13	V
Input Voltage	V _{in}	—	-0.3	V _{dd} +0.3	V
Operating Temperature	T _{opr}	Nor.	0	50	°C
Storage Temperature	T _{stg}	Nor.	-20	+70	°C

ELECTRICAL CHARACTERISTICS (V_{dd} = +5V, T_a = 25°C)

Item	Symbol	Conditions	Min.	Typ.	Max.	Unit
Logic Supply Voltage	V _{dd}	—	4.5	5	5.5	V
"H" Input Voltage	V _{IH}	—	2.2	—	—	V
"L" Input Voltage	V _{IL}	—	—	—	0.6	V
"H" Output Voltage	V _{OH}	—	2.4	—	—	V
"L" Output Voltage	V _{OL}	—	—	—	0.4	V
Supply Current	I _{dd}	—	2	—	—	mA
LCD Driving Voltage	V _{LCD}	V _{dd} -V ₀	4.3	—	4.8	V

Electrical Characteristics

Vdd = 5V±5%
Vss = 0V

Item	Symbol	Condition	Standard value			Unit	Applicable terminal
			Min.	Typ.	Max.		
Power voltage	Vdd		4.5	5.00	5.5	V	Vdd
Input H- level voltage	VIH		2.2	—	Vdd	V	RS, R/ \overline{W} , E DB0~DB7
Input L - level voltage	VIL		-0.3	—	0.6	V	
Output H - level voltage	VOH	- IOH = 0.205mA	2.4	—	—	V	DB0~DB7
Output L - level voltage	VOL	IOL = 1.2mA	—	—	0.4	V	
I/O leakage current	IIL	Vin = 0~Vdd	-1	—	1.0	μ A	RS, R/ \overline{W} , E DB0~DB7
Supply current	Idd	Vdd = 5V	2	—	—	mA	Vdd
LCD operating voltage	VLCD	Vdd-V0	3.0	—	11.0	V	V0

Timing Characteristics

Vdd = 5V±5%
Vss = 0V

Item	Symbol	Min.	Max.	Unit
Enable cycle time	TCYCE	500	—	ns
Enable pulse width	PWEH	220	—	ns
Enable rise / fall time	TER, TEF	—	25	ns
Set-up time	TAS	40	—	ns
Address hold time	TAH	10	—	ns
Data set-up time	TDSH	60	—	ns
Data delay time	TDDR	60	120	ns
Data hold time (writing)	TH	10	—	ns
Data hold time (reading)	TDHR	20	—	ns
Clock oscillating frequency	TOSC	270 (Typ.)		KHz

Timing Chart

◆ FIG.1 WRITE OPERATION

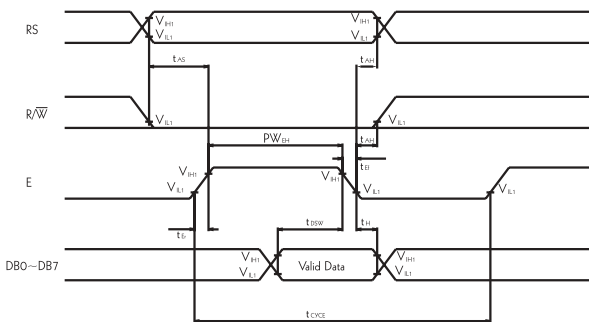

(Write Data from MPU to MODULE)

◆ FIG.2 READ OPERATION

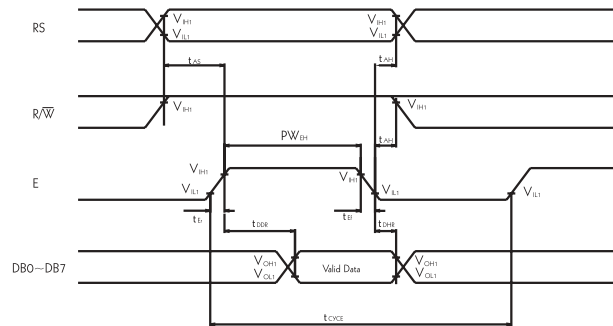

(Read Data from MODULE to MPU)

Interface with MPU

◆ Example of Interface with 8-bit MPU (Z80)

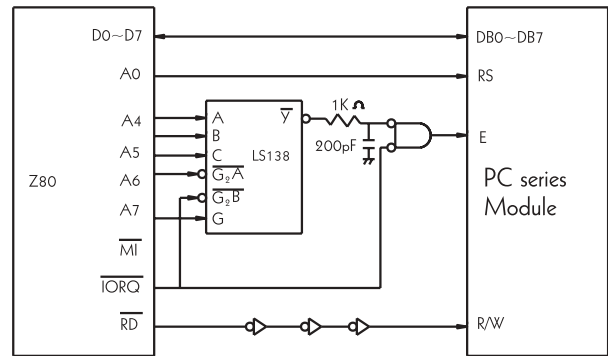
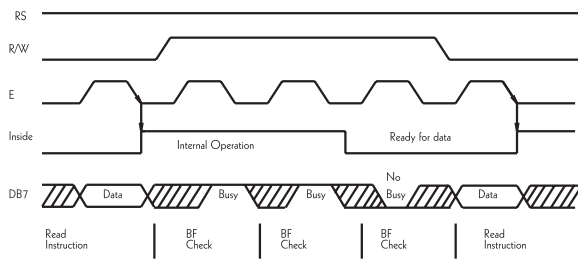

◆ Example of interface with 4-bit MPU

Interface with 4-bit MPU can be made through I/O port of 4-bit MPU. If there are enough I/O ports, data can be transferred by 8-bit, however, if there are not data transfer can be done by 4-bit in twice (select interface is 4-bit long), and timing sequence will be complicated in this case. Please take into account that 2 cycles of BF check is necessary, while 2 cycles of data transfer are also necessary.

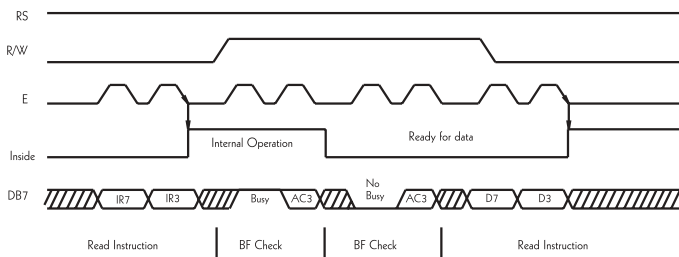

Note: IR7, IR3: 7th bit, 3rd bit of instruction
AC3: 3th bit of Address Counter

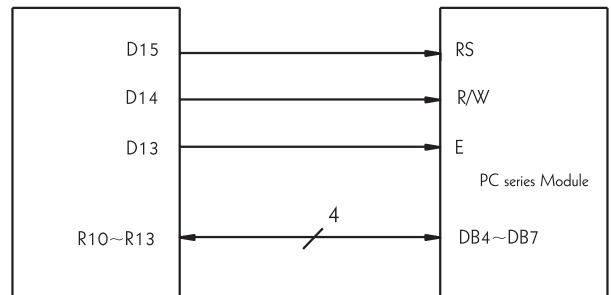

Features

- (1) Interface with 8-bit or 4-bit MPU is available.
- (2) 192 kind of alphabets, numerals, symbols and special characters can be displayed by built-in character generator (ROM).
- (3) Other preferred characters can be displayed by character generator (RAM).
- (4) Various functions of instruction are available by programming.
 - Clear display • Cursor at home • On / off cursor
 - Blink character • Shift display • Shift cursor
 - Read / write display data.....etc.
- (5) Compact and light weight design which can be easily assembled in devices.
- (6) Single power supply +5V drive (except for extended temp. type).
- (7) Low power consumption.

*Interface between data bus line and 4-bit or 8-bit MPU is available.
Data transfer are made in twice in case of 4-bit MPU, and once in case of 8-bit MPU.

◆ If interface data is 4-bit long

Data transfer are made through 4 bus lines from DB4 to DB7. (while the rest of 4 bus lines from DB0 to DB3 are not used.) Data transfer with MPU are completed when 4-bit data are transferred in twice. (first upper 4-bit data. then lower 4-bit data.)

◆ If interface data is 8-bit long

Data transfer are made through all of 8 bus lines from DB0 to DB7.

Example of Power Supply

◆ Normal Temperature Type

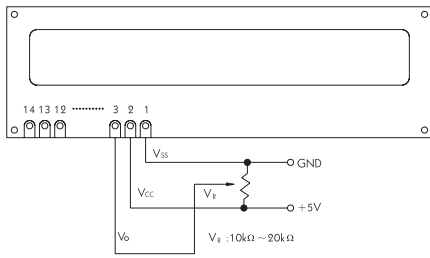

◆ Extended Temperature Type

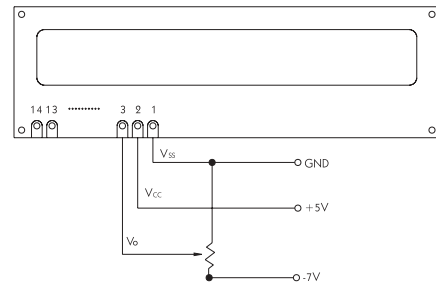

◆ Examples of Temperature Compensation Circuits for Extended Temp Type. (Only for reference)

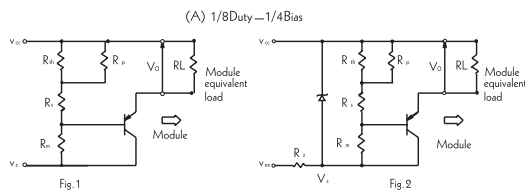

Thermistor: $R_{th}(25^{\circ}C) = 15[k\text{-ohm}]$, $B = 4200[K]$
 Resistors: $R_p = 30[k\text{-ohm}]$, $R_s = 6.8[k\text{-ohm}]$, $R_m = 3.3[k\text{-ohm}]$
 Transistor: PNP Type
 $V_{CC} = +5V$, $V_{SS} = 0V$ (Logic Supply)
 $V_z = -8[V]$ (-7.8 to -8.2[V])
 $V_{ee} < V_z[V]$, $R_z = (V_z - V_{ee}) / 5[k\text{-ohm}]$

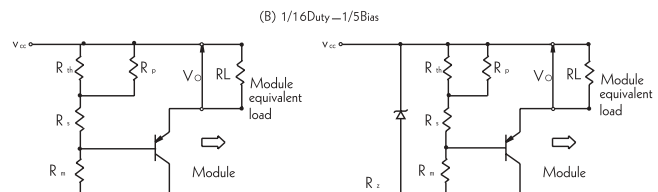

Thermistor: $R_{th}(25^{\circ}C) = 15[k\text{-ohm}]$, $B = 4200[K]$
 Resistors: $R_p = 510[k\text{-ohm}]$, $R_s = 8.2[k\text{-ohm}]$, $R_m = 3.9[k\text{-ohm}]$
 Transistor: PNP Type
 $V_{CC} = +5V$, $V_{SS} = 0V$ (Logic Supply)
 $V_z = -11[V]$ (-10.725 to -11.275[V])
 $V_{ee} < V_z[V]$, $R_z = (V_z - V_{ee}) / 5[k\text{-ohm}]$

Instructions

Instruction	Code										Description	Executed Time(max.)
	RS	R/W	DB7	DB6	DB5	DB4	DB3	DB2	DB1	DB0		
Clear Display	0	0	0	0	0	0	0	0	0	1	Clears all display and returns the cursor to the home position (Address 0)	1.64ms
Cursor At Home	0	0	0	0	0	0	0	0	1	*	Returns the cursor to the home position (Address 0). Also returns the display being shifted to the original position. DD RAM contents remain unchanged.	1.64ms
Entry Mode Set	0	0	0	0	0	0	0	1	D	S	Sets the cursor move direction and specifies or not to shift the display. These operations are performed during data write and read.	40μs
Display On / Off Control	0	0	0	0	0	0	1	D	C	B	Sets ON / OFF of all display (D), cursor NO / OFF (C), and blink of cursor position character (B).	40μs
Cursor / Display Shift	0	0	0	0	0	1	S/C	R/L	*	*	Moves the cursor and shifts the display without changing DD RAM contents.	40μs
Function Set	0	0	0	0	1	DL	N	F	*	*	Sets interface data length (DL) number of display lines (L) and character font (F)	40μs
CG RAM Address Set	0	0	0	1	ACG					Sets the CG RAM address. CG RAM data is sent and received after this setting.	40μs	
DD RAM Address Set	0	0	1	ADD					Sets the DD RAM address. DD RAM data is sent and received after this setting.	40μs		
Busy Flag / Address Read	0	1	BF	AC					Reads Busy flag (FB) indicating internal operation is being performed and reads address counter counts.	0μs		
CG RAM / DD RAM Data Write	1	0	WRITE DATA					Writes data into DD RAM or CG RAM.	40μs			
CG RAM / DD RAM Data Read	1	1	READ DATA					Reads data from DD RAM or CG RAM.	40μs			

Code	Description	Executed Time (max)
I / D = 1 : Increment I / D = 0 : Decrement S = 1 : With display shift S / C = 0 : cursor movement R / L = 1 : Shift to the right R / L = 0 : Shift to the left DL = 1 : 8-bit DL = 0 : 4-bit N = 1 : 2lines N = 0 : 1line F = 1 : 5×10dots F = 0 : 5×7dots BF = 1 : Internal operation is being performed BF = 0 : Instruction acceptable	DD RAM: Display Data RAM CG RAM: Character Generator RAM ACG: CG RAM Address ADD: DD RAM Address Corresponds to cursor address. AC: Address Counter, used for both DD RAM and CG RAM *: Invalid	f_{cp} or $f_{osc} = 250KHz$ However, when frequency changes, execution time also changes Example if f_{cp} or f_{osc} is 270KHz, $70\mu s \times 250 / 270 = 37\mu s$

Power Supply Reset

The internal reset circuit will be operated properly when the following power supply conditions are satisfied. If it is not operated properly, please perform initial setting along with the instruction.

Item	Symbol	Measuring Condition	Standard Value			Unit
			Min.	Typ.	Max.	
Power Supply RISE Time	tree	—	0.1	—	10	mS
Power Supply CFF Time	toff	—	1	—	—	mS

Reset function

◆ Initialization Made by Internal Reset Circuit

HD44780 automatically initializes (resets) when power is supplied (builtin internal reset circuit). The following instructions are executed in initialization. The busy flag (BF) is kept in busy state until initialization ends. (BF=1) The busy state is 10 ms after Vdd reaches to 4.5V.

- (1) Display clear
- (2) Function set
 - DL= 1:8 bit long interface data
 - DL= 0:4 bit F= 0:5 x 7dots character font
 - N= 1:2 lines
 - N= 0:1 line
- (3) Display ON / OFF control
 - D= 0:Display OFF C= 0:Cursor OFF
 - B= 0:Blink OFF
- (4) Entry mode set
 - 1 / D= 1:+1(increment) S= 0:No shift

Note:When conditions stated in power supply conditions using internal reset circuit are not satisfied.The internal reset circuit will not operate properly and initialization will not be performed. Please make initialization using MPU along with instruction.

◆ Initialization along with instruction

If power supply conditions are not satisfied, which for proper operation of internal rest circuit, it is required to make initialization along with instruction. Please make following procedures.

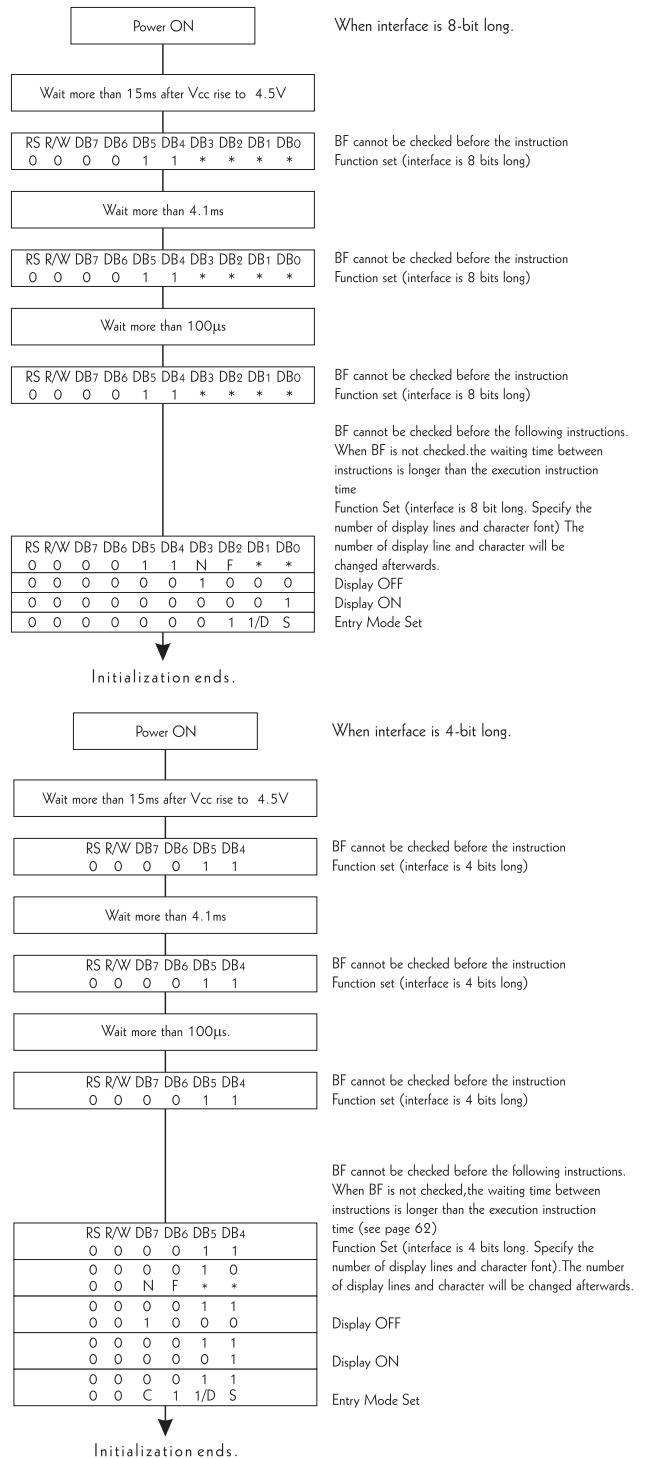

Standard Character Pattern (Powertip Module)

		Higher 4-bit (D4 to Character Code (Hexadecimal))																		
		0	1	2	3	4	5	6	7	8	9	A	B	C	D	E	F			
Lower 4-bit (D0 to D3) of Character Code (Hexadecimal)	0	CG RAM (1)	±		0	P	'	P	S	é	á	'	r	R	B	v				
	1	CG RAM (2)	≡	!	1	A	0	a	4	0	é	i	"	J	+	y	U			
	2	CG RAM (3)	7	"	2	B	R	b	n	é	f	á	°	o	é	é	x			
	3	CG RAM (4)	□	#	3	C	S	c	s	á	á	á	'	P	9	e	v			
	4	CG RAM (5)	⋮	\$	4	D	T	t	t	á	á	t	'	4	r	z	o			
	5	CG RAM (6)	⋮	%	5	E	U	e	u	á	á	á	'	2	t	2	n	7		
	6	CG RAM (7)	⋮	&	6	F	V	v	v	á	á	á	'	u	w	0	0	8		
	7	CG RAM (8)	⋮	'	7	G	W	w	w	á	á	á	'	U	R	X	+	A	L	4
	8	CG RAM (1)	⋮	(8	H	X	x	x	á	á	á	'	÷	÷	÷	÷	÷	÷	÷
	9	CG RAM (2)	⋮)	9	I	V	i	v	á	á	á	'	¿	¿	¿	¿	¿	¿	¿
	A	CG RAM (3)	⋮	*	*	0	Z	z	z	á	á	á	'	0	A	Z	7	2	4	7
	B	CG RAM (4)	⋮	+	;	K	k	k	á	á	á	á	'	g	g	g	g	g	g	g
	C	CG RAM (5)	⋮	=	,	<	L	l	l	á	á	á	'	g	g	g	g	g	g	g
	D	CG RAM (6)	⋮	~	~	M	m	m	á	á	á	á	'	*	*	*	*	*	*	*
	E	CG RAM (7)	⋮	#	.	>	N	n	n	á	á	á	'	0	0	0	0	0	0	0
	F	CG RAM (8)	⋮	@	/	?	0	_	_	á	á	á	'	0	0	0	0	0	0	0

Standard Character Pattern (Elec & Eltek Module)

Upper(4bit) Lower(4bit)		LLLL	LLHL	LLHH	LHLL	LHLH	LHHL	LHHH	HLLL	HLLH	HLHL	HLHH	HHLL	HHLH	HHHL	HHHH
LLLL	CG RAM (1)															
LLLH	(2)															
LLHL	(3)															
LLHH	(4)															
LHLL	(5)															
LHLH	(6)															
LHHL	(7)															
LHHH	(8)															
HLLL	(1)															
HLLH	(2)															
HLHL	(3)															
HLHH	(4)															
HHLL	(5)															
HHLH	(6)															
HHHL	(7)															
HHHH	(8)															

L-934SRC-x SUPER BRIGHT RED
 L-934SRD-x SUPER BRIGHT RED
 L-934SGx SUPER BRIGHT GREEN

Features

- ULTRA BRIGHTNESS.
- BOTH DIFFUSED AND WATER CLEAR LENS ARE AVAILABLE.
- OUTSTANDING MATERIAL EFFICIENCY.
- RELIABLE AND RUGGED.
- IC COMPATIBLE/LOW CURRENT CAPABILITY.

Description

The Super Bright Red source color devices are made with Gallium Aluminum Arsenide Red Light Emitting Diode.

The Super Bright Green source color devices are made with Gallium Phosphide Green Light Emitting Diode.

Package Dimensions

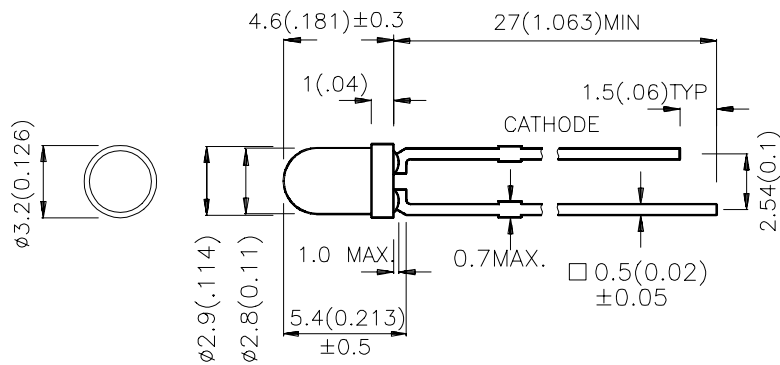

Notes:

1. All dimensions are in millimeters (inches).
2. Tolerance is $\pm 0.25(0.01)$ unless otherwise noted.
3. Lead spacing is measured where the lead emerge package.
4. Specifications are subject to change without notice.

Selection Guide

Part No.	Dice	Lens Type	Iv (mcd) @ 20 mA		Viewing Angle
			Min.	Typ.	θ1/2
L-934SGC	SUPER BRIGHT GREEN(GaP)	WATER CLEAR	80	150	50°
L-934SGD		GREEN DIFFUSED	20	40	60°
L-934SRC-D	SUPER BRIGHT RED (GaAlAs)	WATER CLEAR	500	600	50°
L-934SRC-E			700	900	
L-934SRC-F			1000	1100	
L-934SRC-G			1200	1300	
L-934SRC-H			1400	1700	
L-934SRC-J			1800	2300	
L-934SRD-D			SUPER BRIGHT RED (GaAlAs)	RED DIFFUSED	
L-934SRD-E	200	250			
L-934SRD-F	300	350			
L-934SRD-G	400	500			
L-934SRD-H	600	900			
L-934SRD-J	1000	1200			

Note:

1. θ1/2 is the angle from optical centerline where the luminous intensity is 1/2 the optical centerline value.

Electrical / Optical Characteristics at T_A=25°C

Symbol	Parameter	Device	Typ.	Max.	Units	Test Conditions
λ _{peak}	Peak Wavelength	Super Bright Red Super Bright Green	660 565		nm	IF=20mA
λ _D	Dominate Wavelength	Super Bright Red Super Bright Green	640 568		nm	IF=20mA
Δλ _{1/2}	Spectral Line Halfwidth	Super Bright Red Super Bright Green	20 30		nm	IF=20mA
C	Capacitance	Super Bright Red Super Bright Green	45 15		pF	VF=0V;f=1MHz
V _F	Forward Voltage	Super Bright Red Super Bright Green	1.85 2.2	2.5 2.5	V	IF=20mA
I _R	Reverse Current	All		10	uA	VR = 5V

Absolute Maximum Ratings at $T_A=25^\circ\text{C}$

Parameter	Super Bright Red	Super Bright Green	Units
Power dissipation	100	105	mW
DC Forward Current	30	25	mA
Peak Forward Current [1]	155	140	mA
Reverse Voltage	5	5	V
Operating/Storage Temperature	-40°C To +85°C		
Lead Solder Temperature [2]	260°C For 5 Seconds		

Notes:

- 1/10 Duty Cycle, 0.1ms Pulse Width.
2. 4mm below package base.

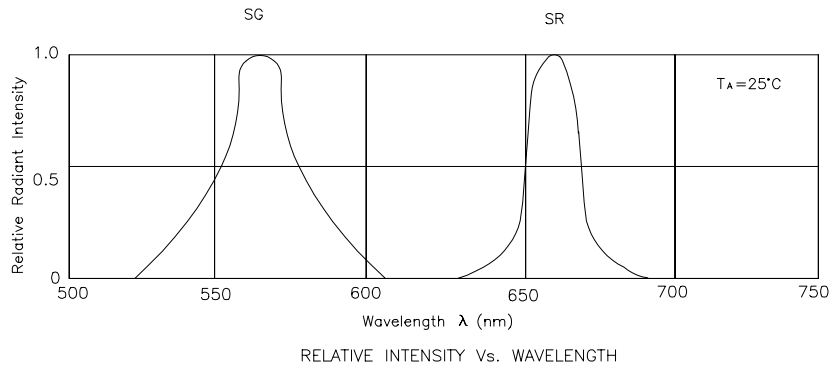

Super Bright Red L-934SRC-x,L-934SRD-x

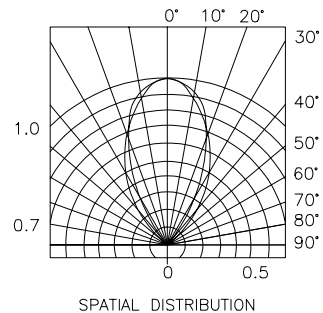
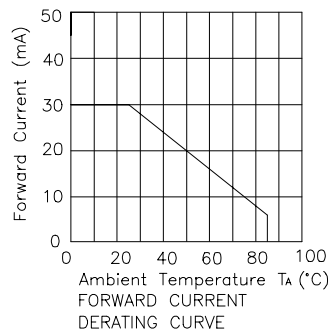
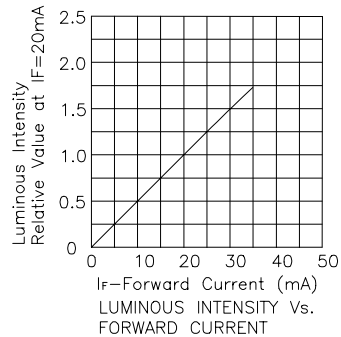
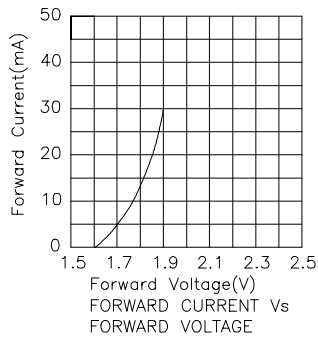

Super Bright Green L-934SGC,L-934SGD

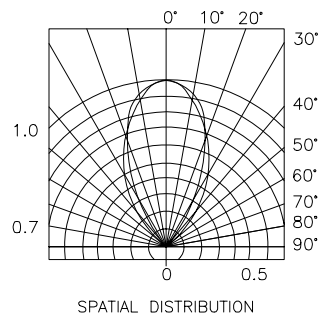
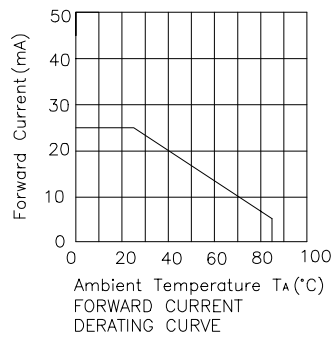
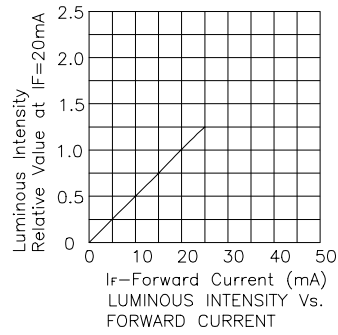
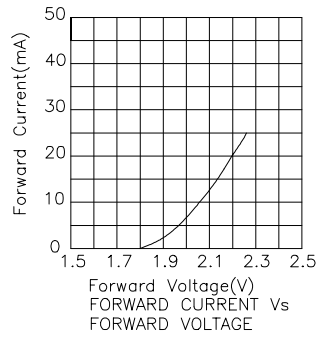

Distributed by:



www.Jameco.com ♦ 1-800-831-4242

The content and copyrights of the attached material are the property of its owner.

Typical Applications **Audio and Visual Equipment** : CD Player / DVD Player / VCR
Home Appliances : Kitchen Appliance

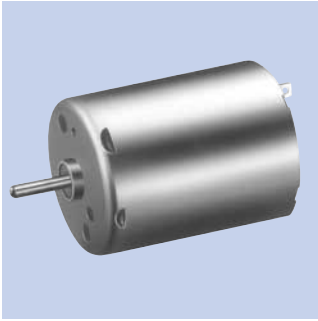

MODEL	VOLTAGE		NO LOAD		AT MAXIMUM EFFICIENCY				STALL			
	OPERATING RANGE	NOMINAL	SPEED	CURRENT	SPEED	CURRENT	TORQUE	OUTPUT	TORQUE		CURRENT	
			r/min	A	r/min	A	mN·m	g·cm	W	mN·m	g·cm	A
RF-370CA-15370	3 ~ 12	12V CONSTANT	5600	0.026	4840	0.17	2.48	25.3	1.25	18.3	187	1.06
RF-370CA-12560	4 ~ 12	8V CONSTANT	2400	0.015	1970	0.069	1.57	16.0	0.32	8.82	90	0.32

DIRECTION OF ROTATION

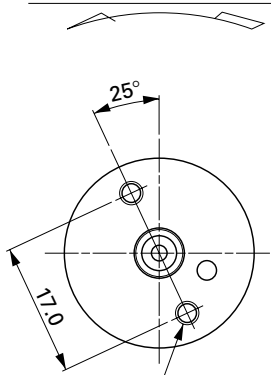

ISO M3.0X0.5 TAPPED HOLE
2 PLACES

Usable machine screw length 2.0 max.
from motor mounting surface.

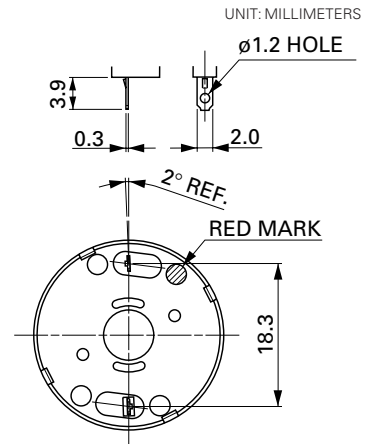
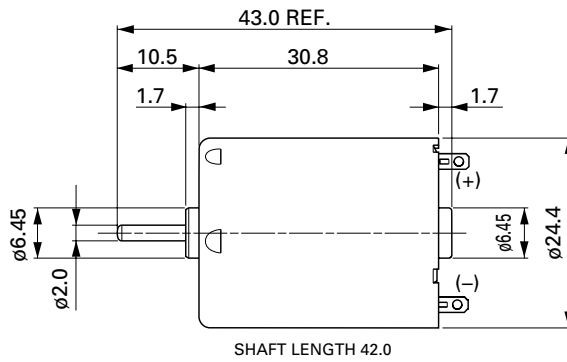

WEIGHT: 51g (APPROX)

RF-370CA-15370

12.0V

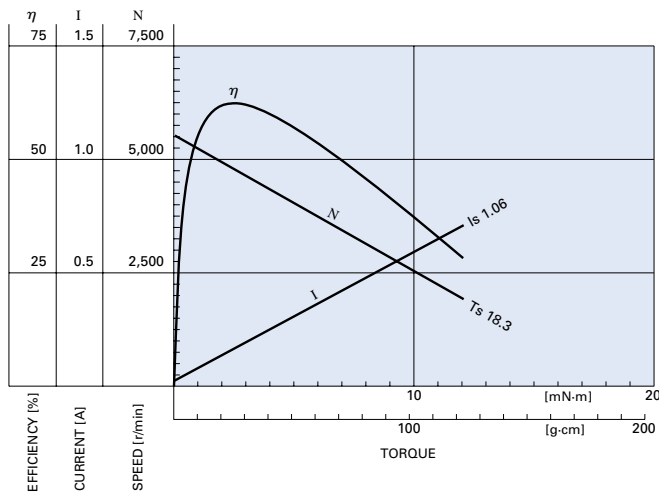

RF-370CA-12560

8.0V

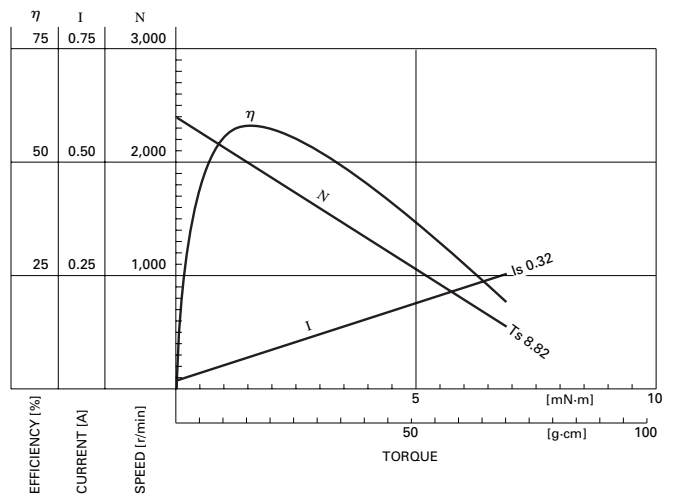

PUSH-PULL FOUR CHANNEL DRIVER WITH DIODES

- 600mA OUTPUT CURRENT CAPABILITY PER CHANNEL
- 1.2A PEAK OUTPUT CURRENT (non repetitive) PER CHANNEL
- ENABLE FACILITY
- OVERTEMPERATURE PROTECTION
- LOGICAL "0" INPUT VOLTAGE UP TO 1.5 V (HIGH NOISE IMMUNITY)
- INTERNAL CLAMP DIODES

DESCRIPTION

The Device is a monolithic integrated high voltage, high current four channel driver designed to accept standard DTL or TTL logic levels and drive inductive loads (such as relays solenoids, DC and stepping motors) and switching power transistors.

To simplify use as two bridges each pair of channels is equipped with an enable input. A separate supply input is provided for the logic, allowing operation at a lower voltage and internal clamp diodes are included.

This device is suitable for use in switching applications at frequencies up to 5 kHz.

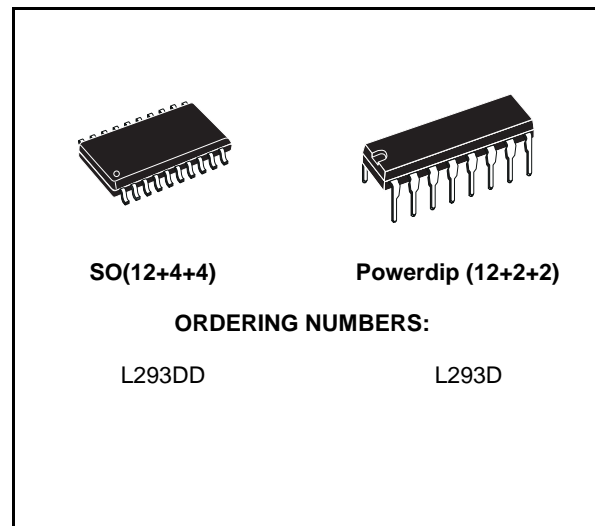

The L293D is assembled in a 16 lead plastic package which has 4 center pins connected together and used for heatsinking

The L293DD is assembled in a 20 lead surface mount which has 8 center pins connected together and used for heatsinking.

BLOCK DIAGRAM

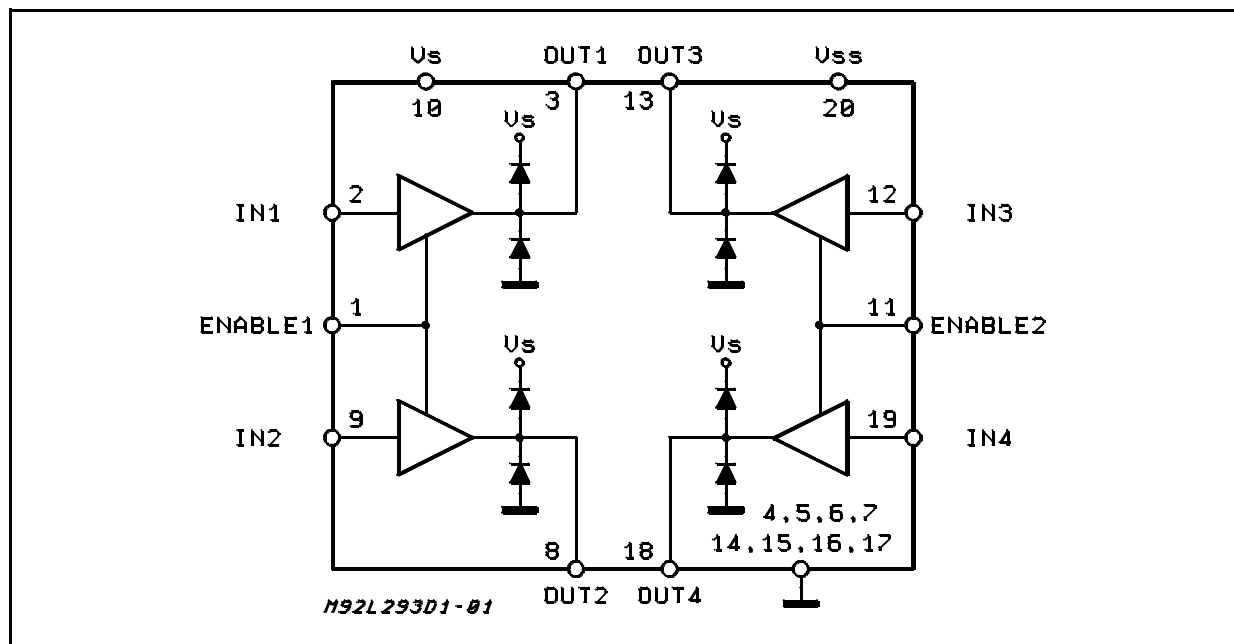

L293D - L293DD

ABSOLUTE MAXIMUM RATINGS

Symbol	Parameter	Value	Unit
V_S	Supply Voltage	36	V
V_{SS}	Logic Supply Voltage	36	V
V_i	Input Voltage	7	V
V_{en}	Enable Voltage	7	V
I_o	Peak Output Current (100 μ s non repetitive)	1.2	A
P_{tot}	Total Power Dissipation at $T_{pins} = 90$ °C	4	W
T_{stg}, T_j	Storage and Junction Temperature	- 40 to 150	°C

PIN CONNECTIONS (Top view)

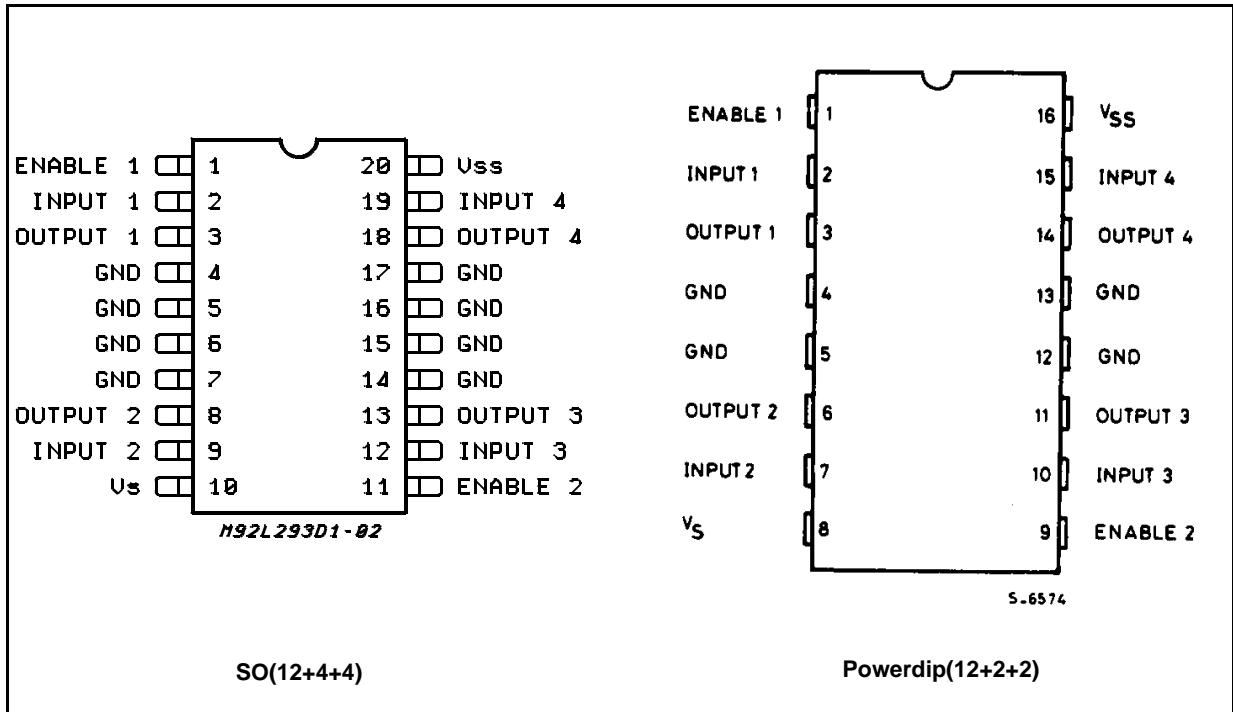

THERMAL DATA

Symbol	Description	DIP	SO	Unit
$R_{th\ j-pins}$	Thermal Resistance Junction-pins	max.	14	°C/W
$R_{th\ j-amb}$	Thermal Resistance junction-ambient	max.	50 (*)	°C/W
$R_{th\ j-case}$	Thermal Resistance Junction-case	max.	-	

(*) With 6sq. cm on board heatsink.

ELECTRICAL CHARACTERISTICS (for each channel, $V_S = 24\text{ V}$, $V_{SS} = 5\text{ V}$, $T_{amb} = 25\text{ }^\circ\text{C}$, unless otherwise specified)

Symbol	Parameter	Test Conditions	Min.	Typ.	Max.	Unit
V_S	Supply Voltage (pin 10)		V_{SS}		36	V
V_{SS}	Logic Supply Voltage (pin 20)		4.5		36	V
I_S	Total Quiescent Supply Current (pin 10)	$V_i = L$; $I_O = 0$; $V_{en} = H$		2	6	mA
		$V_i = H$; $I_O = 0$; $V_{en} = H$		16	24	mA
		$V_{en} = L$			4	mA
I_{SS}	Total Quiescent Logic Supply Current (pin 20)	$V_i = L$; $I_O = 0$; $V_{en} = H$		44	60	mA
		$V_i = H$; $I_O = 0$; $V_{en} = H$		16	22	mA
		$V_{en} = L$		16	24	mA
V_{iL}	Input Low Voltage (pin 2, 9, 12, 19)		-0.3		1.5	V
V_{iH}	Input High Voltage (pin 2, 9, 12, 19)	$V_{SS} \leq 7\text{ V}$	2.3		V_{SS}	V
		$V_{SS} > 7\text{ V}$	2.3		7	V
I_{iL}	Low Voltage Input Current (pin 2, 9, 12, 19)	$V_{iL} = 1.5\text{ V}$			-10	μA
I_{iH}	High Voltage Input Current (pin 2, 9, 12, 19)	$2.3\text{ V} \leq V_{iH} \leq V_{SS} - 0.6\text{ V}$		30	100	μA
V_{enL}	Enable Low Voltage (pin 1, 11)		-0.3		1.5	V
V_{enH}	Enable High Voltage (pin 1, 11)	$V_{SS} \leq 7\text{ V}$	2.3		V_{SS}	V
		$V_{SS} > 7\text{ V}$	2.3		7	V
I_{enL}	Low Voltage Enable Current (pin 1, 11)	$V_{enL} = 1.5\text{ V}$		-30	-100	μA
I_{enH}	High Voltage Enable Current (pin 1, 11)	$2.3\text{ V} \leq V_{enH} \leq V_{SS} - 0.6\text{ V}$			± 10	μA
$V_{CE(sat)H}$	Source Output Saturation Voltage (pins 3, 8, 13, 18)	$I_O = -0.6\text{ A}$		1.4	1.8	V
$V_{CE(sat)L}$	Sink Output Saturation Voltage (pins 3, 8, 13, 18)	$I_O = +0.6\text{ A}$		1.2	1.8	V
V_F	Clamp Diode Forward Voltage	$I_O = 600\text{ nA}$		1.3		V
t_r	Rise Time (*)	0.1 to 0.9 V_O		250		ns
t_f	Fall Time (*)	0.9 to 0.1 V_O		250		ns
t_{on}	Turn-on Delay (*)	0.5 V_i to 0.5 V_O		750		ns
t_{off}	Turn-off Delay (*)	0.5 V_i to 0.5 V_O		200		ns

(*) See fig. 1.

TRUTH TABLE (one channel)

Input	Enable (*)	Output
H	H	H
L	H	L
H	L	Z
L	L	Z

Z = High output impedance

(*) Relative to the considered channel

Figure 1: Switching Times

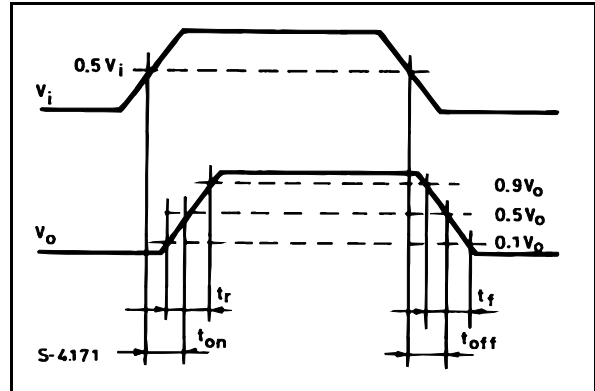
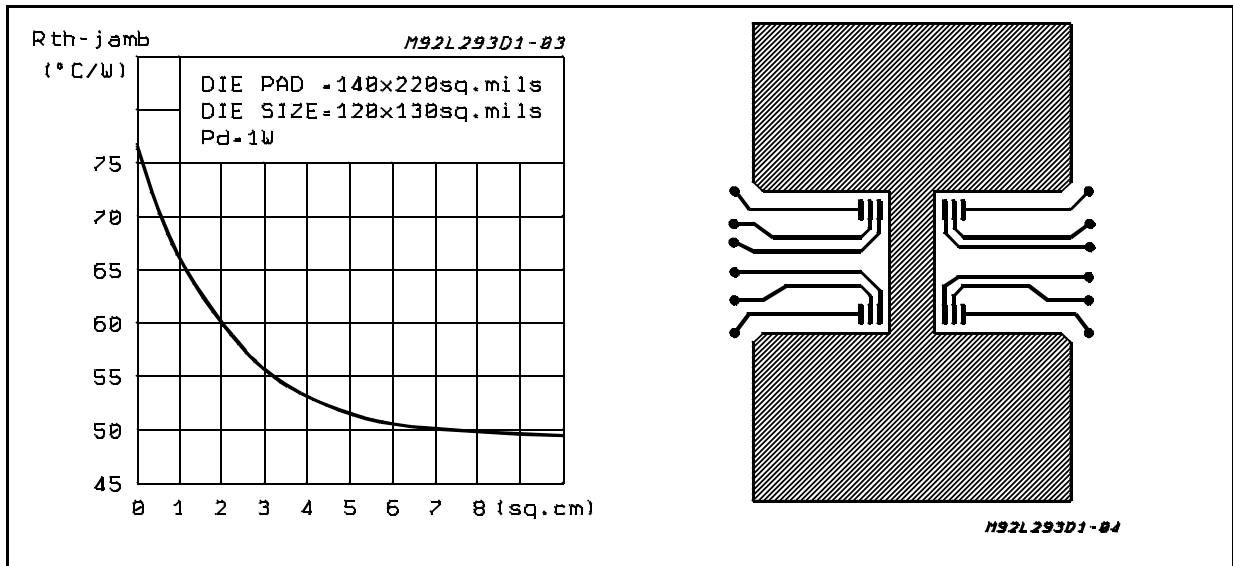
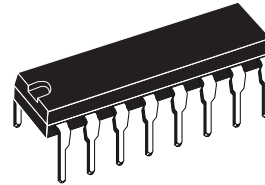

Figure 2: Junction to ambient thermal resistance vs. area on board heatsink (SO12+4+4 package)



DIM.	mm			inch		
	MIN.	TYP.	MAX.	MIN.	TYP.	MAX.
a1	0.51			0.020		
B	0.85		1.40	0.033		0.055
b		0.50			0.020	
b1	0.38		0.50	0.015		0.020
D			20.0			0.787
E		8.80			0.346	
e		2.54			0.100	
e3		17.78			0.700	
F			7.10			0.280
I			5.10			0.201
L		3.30			0.130	
Z			1.27			0.050

OUTLINE AND MECHANICAL DATA



Powerdip 16

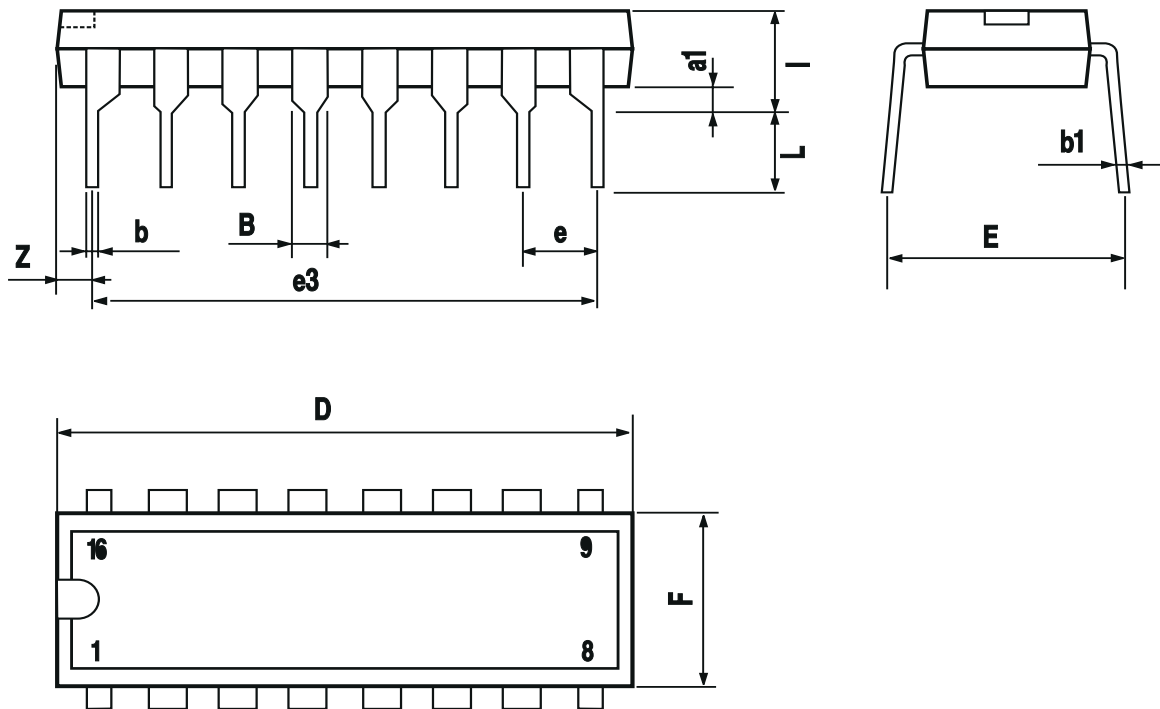

L293D - L293DD

DIM.	mm			inch		
	MIN.	TYP.	MAX.	MIN.	TYP.	MAX.
A	2.35		2.65	0.093		0.104
A1	0.1		0.3	0.004		0.012
B	0.33		0.51	0.013		0.020
C	0.23		0.32	0.009		0.013
D	12.6		13	0.496		0.512
E	7.4		7.6	0.291		0.299
e		1.27			0.050	
H	10		10.65	0.394		0.419
h	0.25		0.75	0.010		0.030
L	0.4		1.27	0.016		0.050
K	0° (min.)8° (max.)					

OUTLINE AND MECHANICAL DATA

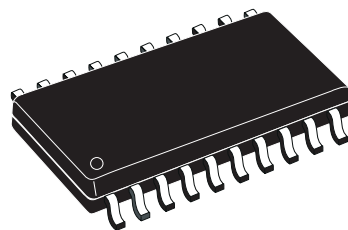

SO20

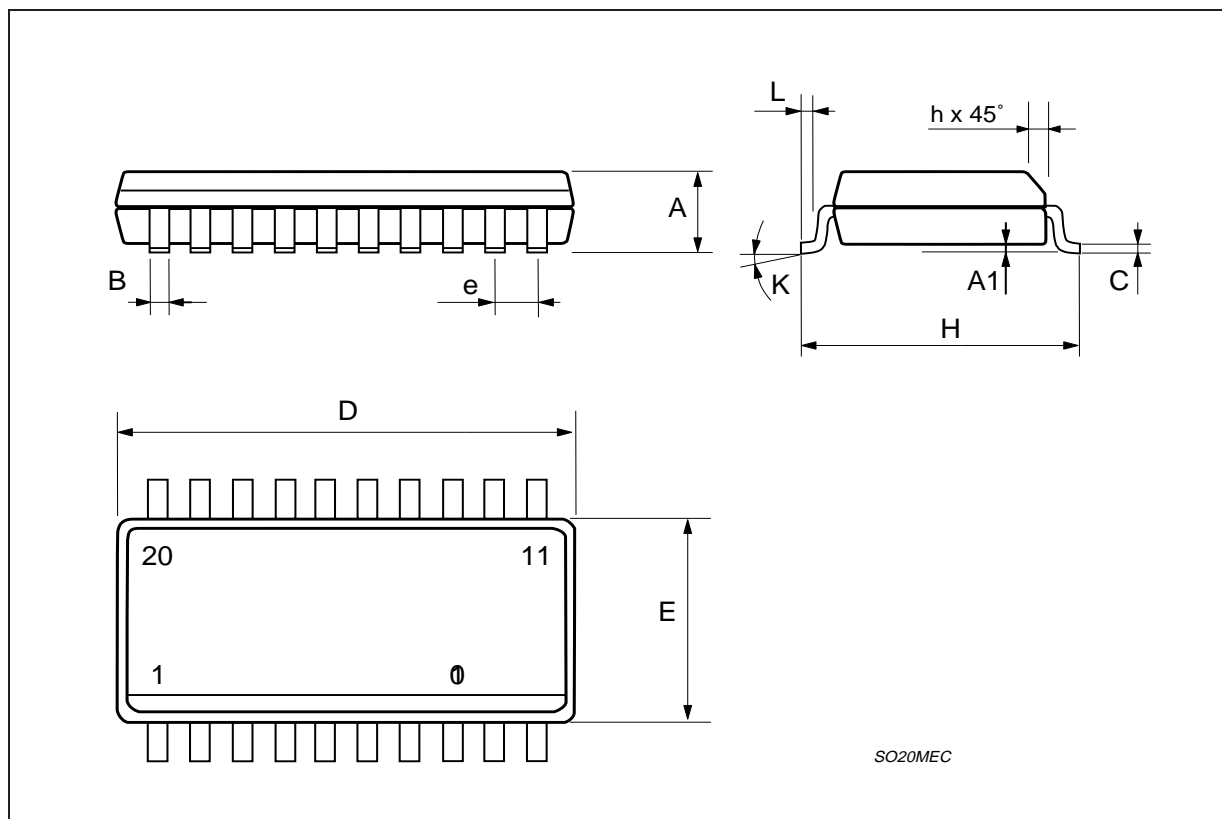

Information furnished is believed to be accurate and reliable. However, STMicroelectronics assumes no responsibility for the consequences of use of such information nor for any infringement of patents or other rights of third parties which may result from its use. No license is granted by implication or otherwise under any patent or patent rights of STMicroelectronics. Specification mentioned in this publication are subject to change without notice. This publication supersedes and replaces all information previously supplied. STMicroelectronics products are not authorized for use as critical components in life support devices or systems without express written approval of STMicroelectronics.

The ST logo is a registered trademark of STMicroelectronics

© 2003 STMicroelectronics – Printed in Italy – All Rights Reserved

STMicroelectronics GROUP OF COMPANIES

Australia - Brazil - Canada - China - Finland - France - Germany - Hong Kong - India - Israel - Italy - Japan - Malaysia - Malta - Morocco - Singapore - Spain - Sweden - Switzerland - United Kingdom - United States.

<http://www.st.com>

MG996R High Torque Metal Gear Dual Ball Bearing Servo

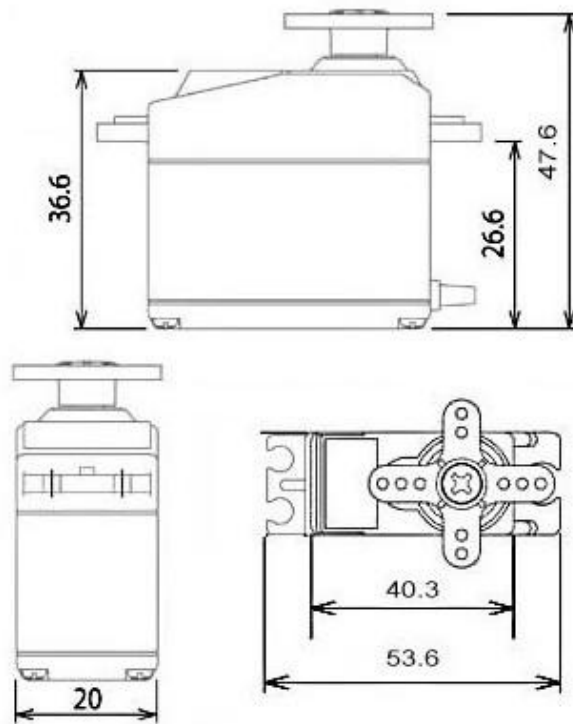

This High-Torque MG996R Digital Servo features metal gearing resulting in extra high 10kg stalling torque in a tiny package. The MG996R is essentially an upgraded version of the famous MG995 servo, and features upgraded shock-proofing and a redesigned PCB and IC control system that make it much more accurate than its predecessor. The gearing and motor have also been upgraded to improve dead bandwith and centering. The unit comes complete with 30cm wire and 3 pin 'S' type female header connector that fits most receivers, including Futaba, JR, GWS, Cirrus, Blue Bird, Blue Arrow, Corona, Berg, Spektrum and Hitec.

This high-torque standard servo can rotate approximately 120 degrees (60 in each direction). You can use any servo code, hardware or library to control these servos, so it's great for beginners who want to make stuff move without building a motor controller with feedback & gear box, especially since it will fit in small places. The MG996R Metal Gear Servo also comes with a selection of arms and hardware to get you set up nice and fast!

Specifications

- Weight: 55 g
- Dimension: 40.7 x 19.7 x 42.9 mm approx.
- Stall torque: 9.4 kgf·cm (4.8 V), 11 kgf·cm (6 V)
- Operating speed: 0.17 s/60° (4.8 V), 0.14 s/60° (6 V)

- Operating voltage: 4.8 V a 7.2 V
- Running Current 500 mA – 900 mA (6V)
- Stall Current 2.5 A (6V)
- Dead band width: 5 μ s
- Stable and shock proof double ball bearing design
- Temperature range: 0 $^{\circ}$ C – 55 $^{\circ}$ C

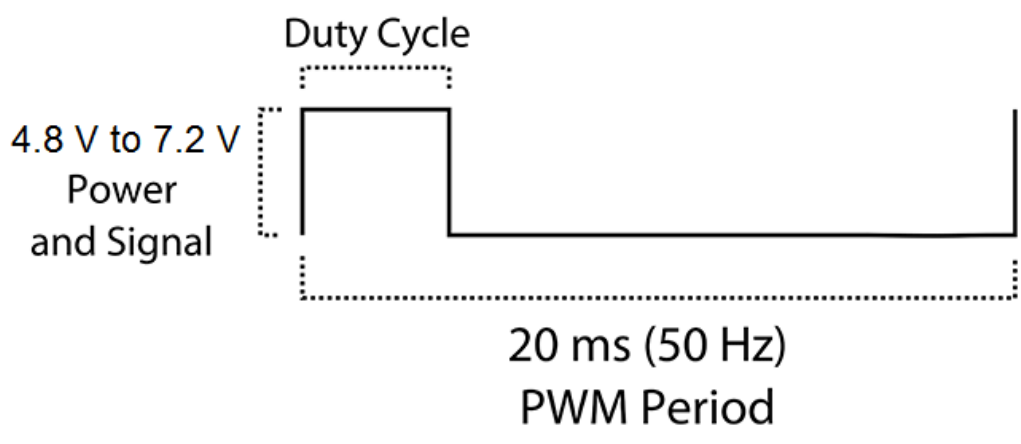
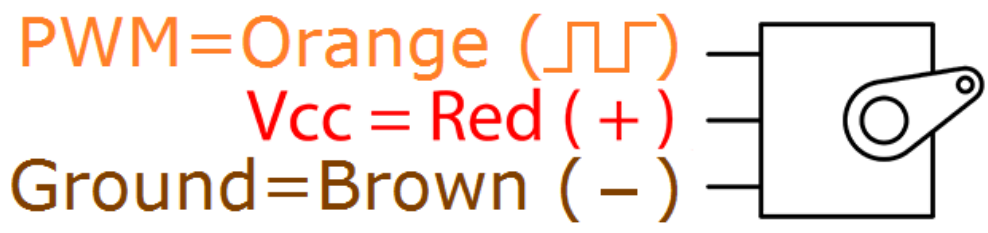



Technical Data Sheet

3mm Silicon PIN Photodiode T-1

PD204-6C/L3

Features

- Fast response time
- High photo sensitivity
- Small junction capacitance
- Pb free

Descriptions

PD204-6C/L3 is a high speed and high sensitive PIN photodiode in a standard 3 Φ plastic package. Due to its water clear epoxy the device is sensitive to visible and infrared radiation.



Applications

- Automatic door sensor
- Camera
- Game machine
- High speed photo detector

Device Selection Guide

LED Part No.	Chip	Lens Color
	Material	
PD	Silicon	Water clear

Package Dimensions

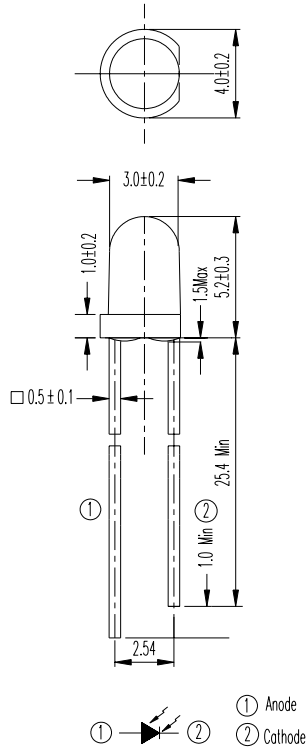

- Notes:** 1.All dimensions are in millimeters
2.Tolerances unless dimensions $\pm 0.25\text{mm}$

Absolute Maximum Ratings (Ta=25°C)

Parameter	Symbol	Rating	Units
Reverse Voltage	V_R	32	V
Operating Temperature	T_{opr}	-25 ~ +85	°C
Storage Temperature	T_{stg}	-40 ~ +85	°C
Soldering Temperature	T_{sol}	260	°C
Power Dissipation at(or below) 25°C Free Air Temperature	P_c	150	mW

Notes: *1:Soldering time ≤ 5 seconds.

Electro-Optical Characteristics (Ta=25°C)

Parameter	Symbol	Condition	Min	Typ	Max	Unit
Rang Of Spectral Bandwidth	$\lambda_{0.5}$	---	400	---	1100	nm
Wavelength Of Peak Sensitivity	λ_p	---	---	940	---	nm
Open-Circuit Voltage	V_{OC}	Ee=5mW/cm ² $\lambda_p=940\text{nm}$	---	0.44	---	V
Short- Circuit Current	I_{SC}	Ee=1mW/cm ² $\lambda_p=940\text{nm}$	---	10	---	μA
Reverse Light Current	I_L	Ee=1mW/cm ² $\lambda_p=940\text{nm}$ $V_R=5\text{V}$	---	10	---	μA
Reverse Dark Current	I_D	Ee=0mW/cm ² $V_R=10\text{V}$	---	---	10	nA
Reverse Breakdown Voltage	B_{VR}	Ee=0mW/cm ² $I_R=100\mu\text{A}$	32	170	---	V
Total Capacitance	C_t	Ee=0mW/cm ² $V_R=5\text{V}$ $f=1\text{MHz}$	---	10	---	pF
Rise Time	t_r	$V_R=10\text{V}$ $R_L=100\Omega$	---	10	---	nS
Fall Time	t_f		---	10	---	

Typical Electro-Optical Characteristics Curves

Fig.1 Power Dissipation vs. Ambient Temperature

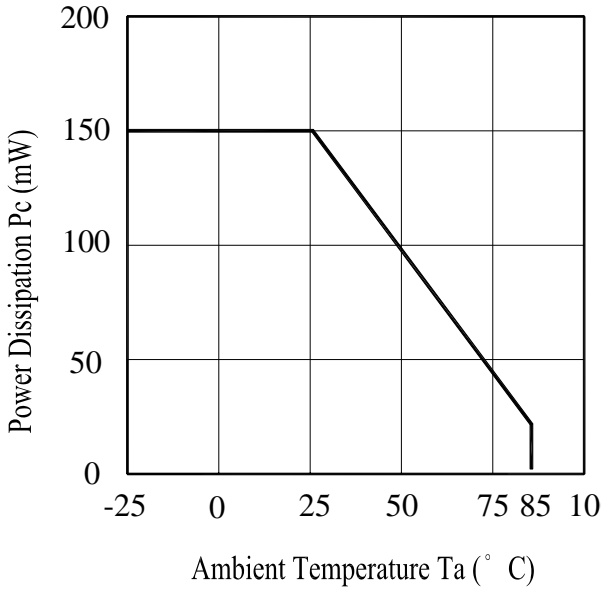

Fig.2 Spectral Sensitivity

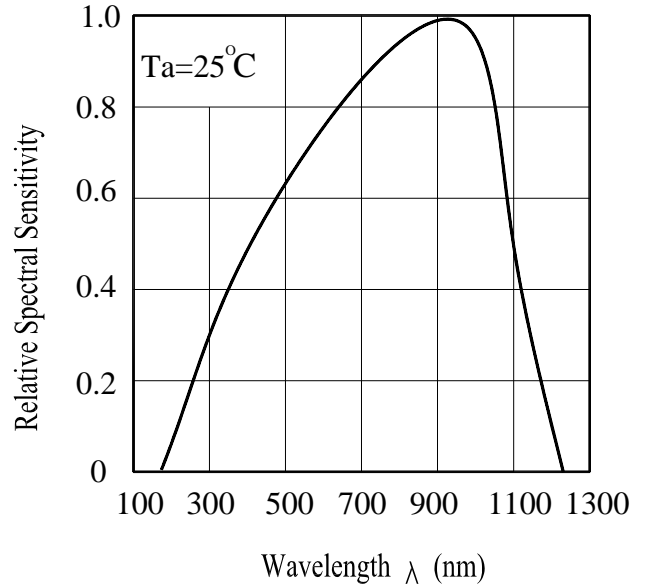

Fig.3 Dark Current vs. Ambient Temperature

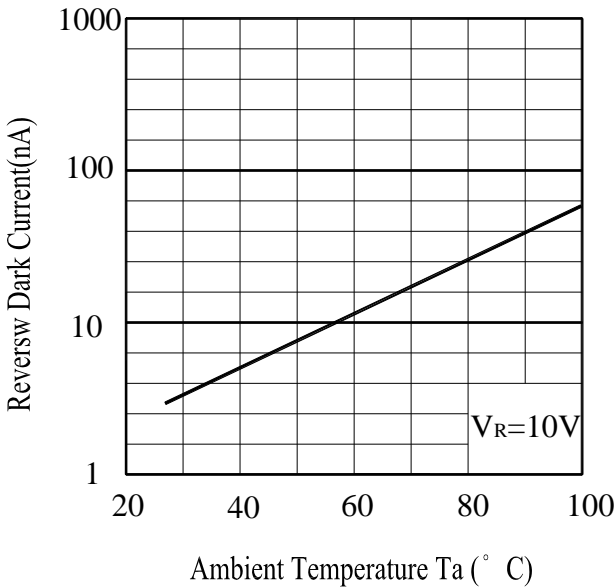
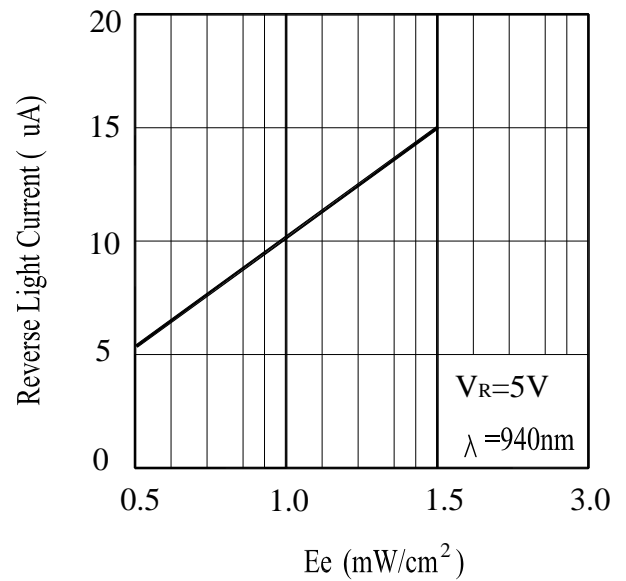

Fig. 4 Reverse Light Current vs. E_e



Typical Electro-Optical Characteristics Curves

Fig.5 Terminal Capacitance vs.

Reverse Voltage

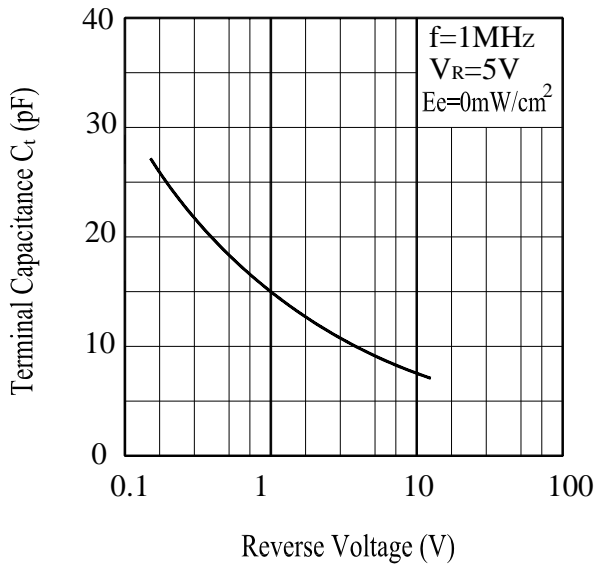
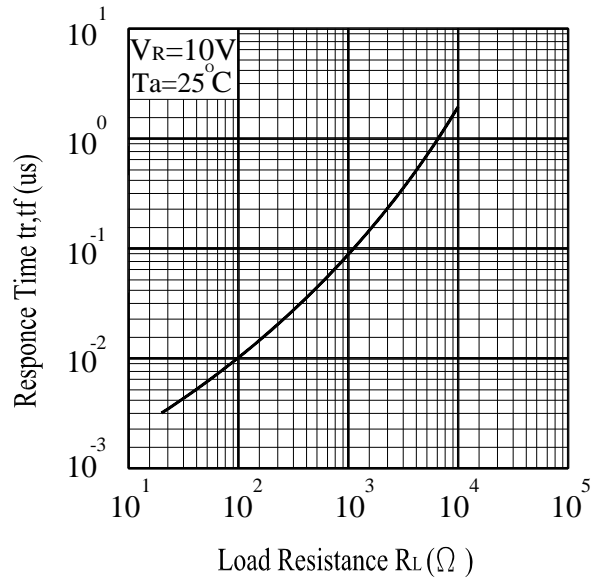

Fig.6 Response Time vs.

Load Resistance



Reliability Test Item And Condition

The reliability of products shall be satisfied with items listed below.

Confidence level : 90%

LTPD : 10%

NO.	Item	Test Conditions	Test Hours/ Cycles	Sample Sizes	Failure Judgement Criteria	Ac/Re
1	Solder Heat	TEMP. : 260°C±5°C	10secs	22pcs		0/1
2	Temperature Cycle	H : +100°C 15mins ↕ 5mins L : -40°C 15mins	50Cycles	22pcs	$I_L \leq L \times 0.8$ L : Lower	0/1
3	Thermal Shock	H : +100°C 5mins ↕ 10secs L : -10°C 5mins	50Cycles	22pcs	Specification Limit	0/1
4	High Temperature Storage	TEMP. : +100°C	1000hrs	22pcs		0/1
5	Low Temperature Storage	TEMP. : -40°C	1000hrs	22pcs		0/1
6	DC Operating Life	$V_R=5V$	1000hrs	22pcs		0/1
7	High Temperature/ High Humidity	85°C / 85% R.H	1000hrs	22pcs		0/1



Packing Quantity Specification

1.1000PCS/1Bag , 4Bags/1Box

2.10Boxes/1Carton

Label Form Specification

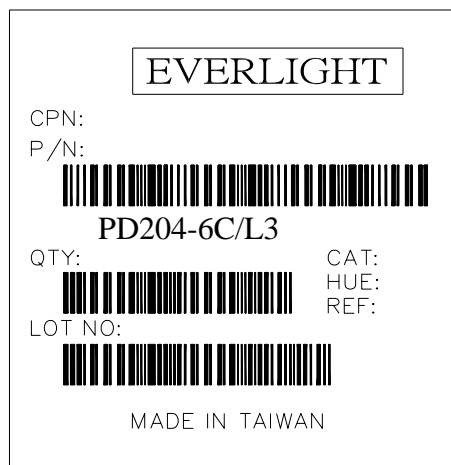

CPN: Customer's Production Number

P/N : Production Number

QTY: Packing Quantity

CAT: Ranks

HUE: Peak Wavelength

REF: Reference

LOT No: Lot Number

MADE IN TAIWAN: Production Place

Notes

1. Above specification may be changed without notice. EVERLIGHT will reserve authority on material change for above specification.
2. When using this product, please observe the absolute maximum ratings and the instructions for using outlined in these specification sheets. EVERLIGHT assumes no responsibility for any damage resulting from use of the product which does not comply with the absolute maximum ratings and the instructions included in these specification sheets.
3. These specification sheets include materials protected under copyright of EVERLIGHT corporation. Please don't reproduce or cause anyone to reproduce them without EVERLIGHT's consent.

EVERLIGHT ELECTRONICS CO., LTD.

Office: No 25, Lane 76, Sec 3, Chung Yang Rd,
Tucheng, Taipei 236, Taiwan, R.O.C

Tel: 886-2-2267-2000, 2267-9936

Fax: 886-2267-6244, 2267-6189, 2267-6306

<http://www.everlight.com>

Mouser Electronics

Authorized Distributor

Click to View Pricing, Inventory, Delivery & Lifecycle Information:

[Everlight:](#)

[EL-PD204-6C/L3](#)