



13N50

Preliminary

Power MOSFET

500V N-CHANNEL MOSFET

■ DESCRIPTION

The UTC **13N50** is an N-Channel enhancement mode power MOSFET. The device adopts planar stripe and uses DMOS technology to minimize and provide lower on-state resistance and faster switching speed. It can also withstand high energy pulse under the avalanche and commutation mode conditions.

The UTC **13N50** is ideally suitable for high efficiency switch mode power supply, power factor correction, electronic lamp ballast based on half bridge topology.

■ FEATURES

- * $R_{DS(ON)} = 0.48\Omega @ V_{GS} = 10V$
- * Ultra low gate charge (typical 43 nC)
- * Low reverse transfer Capacitance ($C_{RSS} =$ typical 20pF)
- * Fast switching capability
- * Avalanche energy tested
- * Improved dv/dt capability, high ruggedness

■ SYMBOL

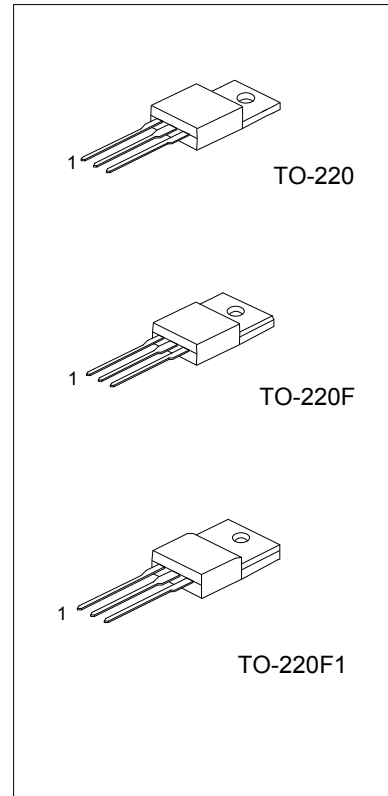
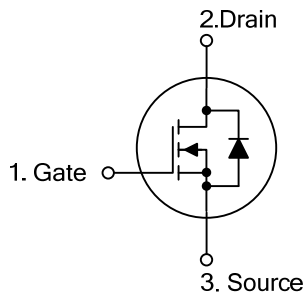

■ ORDERING INFORMATION

Ordering Number		Package	Pin Assignment			Packing
Lead Free	Halogen Free		1	2	3	
13N50L-TA3-T	13N50G-TA3-T	TO-220	G	D	S	Tube
13N50L-TF3-T	13N50G-TF3-T	TO-220F	G	D	S	Tube
13N50L-TF1-T	13N50G-TF1-T	TO-220F1	G	D	S	Tube

<p>13N50L-TA3-T</p> <p>(1) Packing Type (2) Package Type (3) Lead Free</p>	<p>(1) T: Tube (2) TA3: TO-220, TF3: TO-220F, TF1:TO-220F1 (3) L: Lead Free, G: Halogen Free</p>
--	--

www.DataSheet4U.com

■ ABSOLUTE MAXIMUM RATINGS ($T_C = 25^\circ\text{C}$, unless otherwise specified)

PARAMETER	SYMBOL	RATINGS	UNIT
Drain-Source Voltage	V_{DSS}	500	V
Gate-Source Voltage	V_{GSS}	± 30	V
Continuous Drain Current	I_D	13	A
Pulsed Drain Current (Note 2)	I_{DM}	52	A
Avalanche Current (Note 2)	I_{AR}	13	A
Single Pulsed Avalanche Energy (Note 3)	E_{AS}	810	mJ
Repetitive Avalanche Energy (Note 2)	E_{AR}	17	mJ
Peak Diode Recovery dv/dt (Note 4)	dv/dt	4.5	V/ns
Power Dissipation ($T_C=25^\circ\text{C}$)	TO-220	168	W
	TO-220F	48	W
Junction Temperature	T_J	+150	$^\circ\text{C}$
Storage Temperature	T_{STG}	-55~+150	$^\circ\text{C}$

Notes: 1. Absolute maximum ratings are those values beyond which the device could be permanently damaged.

Absolute maximum ratings are stress ratings only and functional device operation is not implied.

2. Repetitive Rating : Pulse width limited by maximum junction temperature

3. $L = 9.3\text{mA}$, $I_{AS} = 13\text{A}$, $V_{DD} = 50\text{V}$, $R_G = 25\Omega$, Starting $T_J = 25^\circ\text{C}$

4. $I_{SD} \leq 13\text{A}$, $di/dt \leq 200\text{A}/\mu\text{s}$, $V_{DD} \leq BV_{DSS}$, Starting $T_J = 25^\circ\text{C}$

■ THERMAL DATA

PARAMETER	SYMBOL	RATINGS	UNIT
Junction to Ambient	TO-220	62.5	$^\circ\text{C}/\text{W}$
	TO-220F	62.5	$^\circ\text{C}/\text{W}$
Junction to Case	TO-220	0.74	$^\circ\text{C}/\text{W}$
	TO-220F	2.58	$^\circ\text{C}/\text{W}$

■ ELECTRICAL CHARACTERISTICS ($T_C = 25^\circ\text{C}$, unless otherwise specified)

PARAMETER	SYMBOL	TEST CONDITIONS	MIN	TYP	MAX	UNIT
OFF CHARACTERISTICS						
Drain-Source Breakdown Voltage	BV_{DSS}	$V_{GS} = 0\text{V}$, $I_D = 250\mu\text{A}$	500			V
Drain-Source Leakage Current	I_{DSS}	$V_{DS} = 500\text{V}$, $V_{GS} = 0\text{V}$			1	μA
Gate-Source Leakage Current	I_{GSS}	$V_{GS} = 30\text{V}$, $V_{DS} = 0\text{V}$			100	nA
		$V_{GS} = -30\text{V}$, $V_{DS} = 0\text{V}$			-100	nA
Breakdown Voltage Temperature Coefficient	$\Delta BV_{DSS}/\Delta T_J$	$I_D = 250\mu\text{A}$ Referenced to 25°C		0.5		$\text{V}/^\circ\text{C}$
ON CHARACTERISTICS						
Gate Threshold Voltage	$V_{GS(TH)}$	$V_{DS} = V_{GS}$, $I_D = 250\mu\text{A}$	2.0		4.0	V
Static Drain-Source On-State Resistance	$R_{DS(ON)}$	$V_{GS} = 10\text{V}$, $I_D = 6.5\text{A}$		0.33	0.43	Ω
Forward Transconductance	g_{FS}	$V_{DS} = 50\text{V}$, $I_D = 6.25\text{A}$ (Note 1)		10		S
DYNAMIC CHARACTERISTICS						
Input Capacitance	C_{ISS}	$V_{DS} = 25\text{V}$, $V_{GS} = 0\text{V}$, $f = 1.0\text{MHz}$		1800	2300	pF
Output Capacitance	C_{OSS}			245	320	pF
Reverse Transfer Capacitance	C_{RSS}			25	35	pF
SWITCHING CHARACTERISTICS						
Turn-On Delay Time	$t_{D(ON)}$	$V_{DD} = 250\text{V}$, $I_D = 13\text{A}$ $R_G = 25\Omega$ (Note 1,2)		40	90	nS
Turn-On Rise Time	t_R			140	290	nS
Turn-Off Delay Time	$t_{D(OFF)}$			100	210	nS
Turn-Off Fall Time	t_F			85	180	nS
Total Gate Charge	Q_G	$V_{DS} = 400\text{V}$, $I_D = 13\text{A}$, $V_{GS} = 10\text{V}$ (Note 1, 2)		45	60	nC
Gate-Source Charge	Q_{GS}			11		nC
Gate-Drain Charge	Q_{GD}			22		nC

■ ELECTRICAL CHARACTERISTICS(Cont.)

PARAMETER	SYMBOL	TEST CONDITIONS	MIN	TYP	MAX	UNIT
DRAIN-SOURCE DIODE CHARACTERISTICS AND MAXIMUM RATINGS						
Drain-Source Diode Forward Voltage	V_{SD}	$V_{GS} = 0V, I_S = 13 A$			1.4	V
Maximum Continuous Drain-Source Diode Forward Current	I_S				13	A
Maximum Pulsed Drain-Source Diode Forward Current	I_{SM}				52	A
Reverse Recovery Time	t_{RR}	$V_{GS} = 0V, I_S = 13A,$		290		nS
Reverse Recovery Charge	Q_{RR}	$di_F / dt = 100A/\mu s$ (Note 1)		2.6		μC

Notes: 1. Pulse Test : Pulse width $\leq 300\mu s$, Duty cycle $\leq 2\%$

2. Essentially independent of operating ambient temperature

■ TEST CIRCUITS AND WAVEFORMS

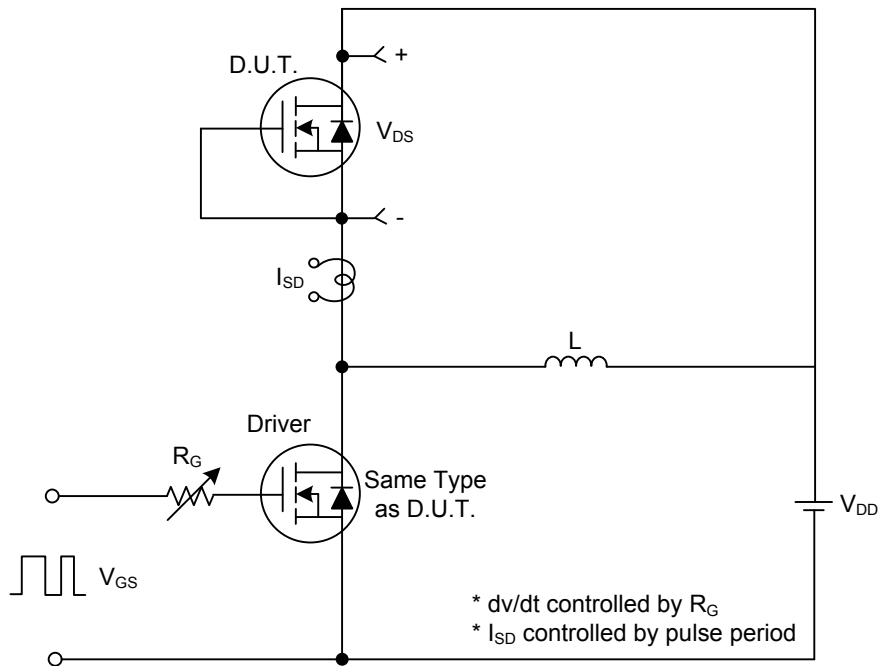

Fig. 1A Peak Diode Recovery dv/dt Test Circuit

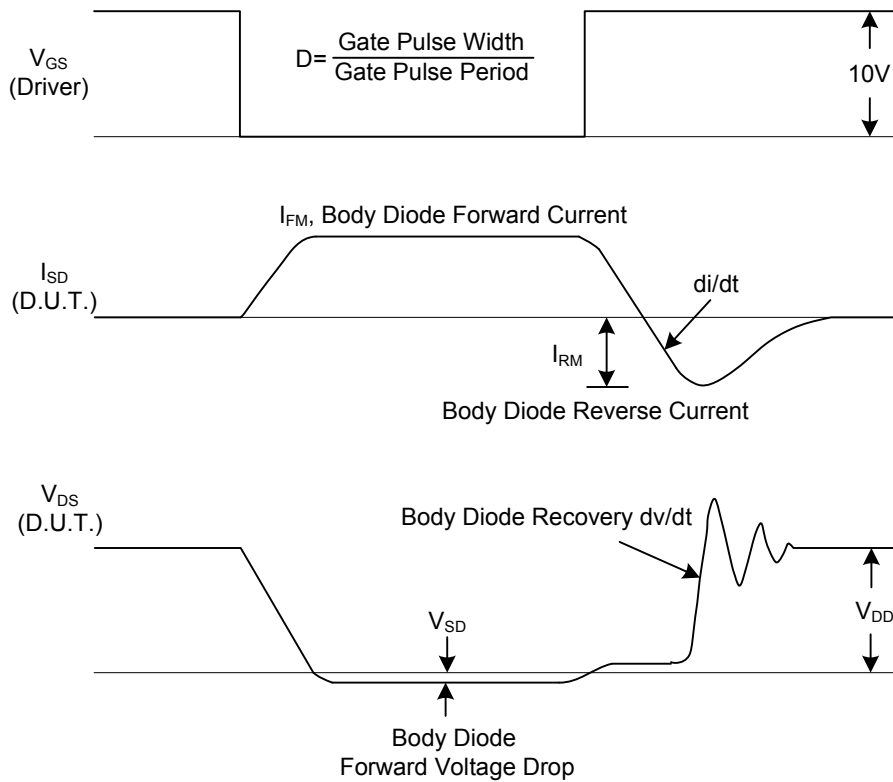

Fig. 1B Peak Diode Recovery dv/dt Waveforms

■ TEST CIRCUITS AND WAVEFORMS (Cont.)

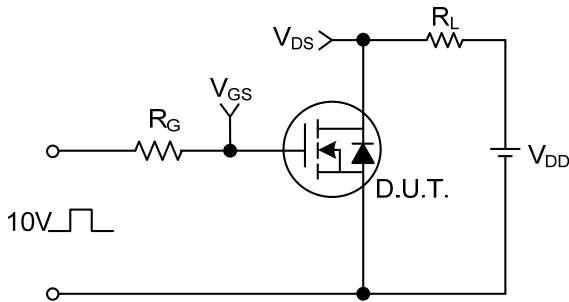

Fig. 2A Switching Test Circuit

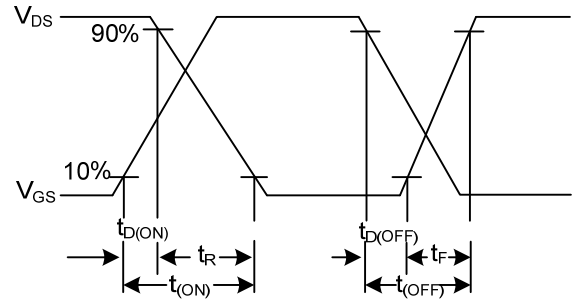

Fig. 2B Switching Waveforms

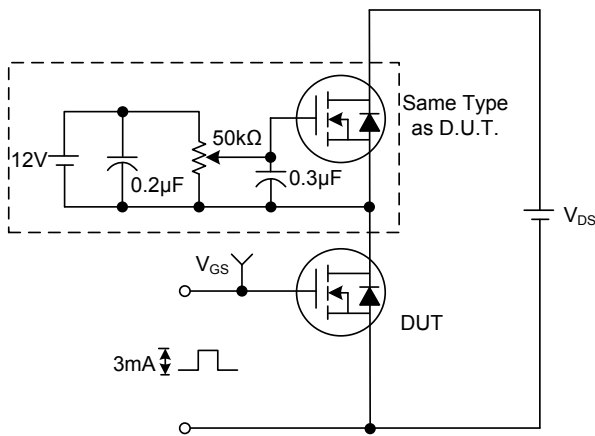

Fig. 3A Gate Charge Test Circuit

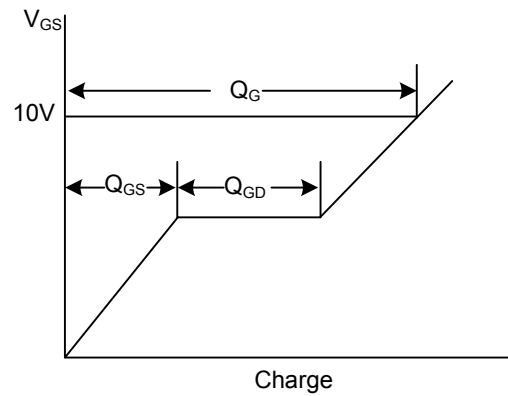

Fig. 3B Gate Charge Waveform

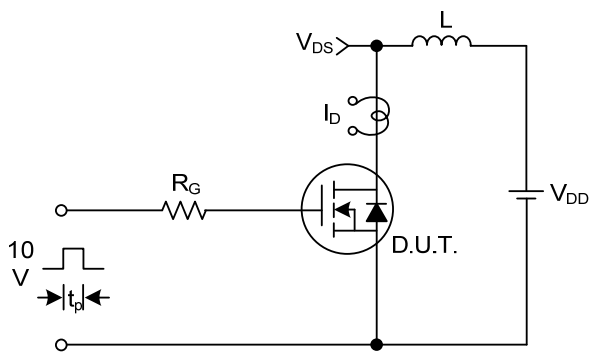

Fig. 4A Unclamped Inductive Switching Test Circuit

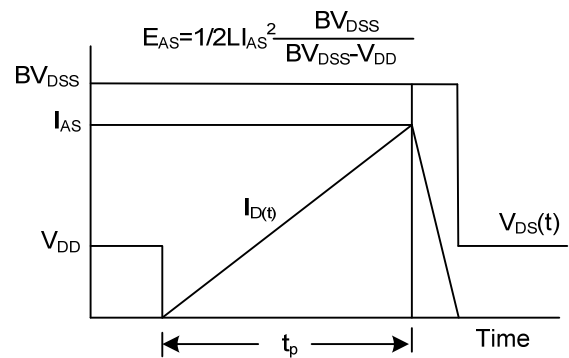

Fig. 4B Unclamped Inductive Switching Waveforms

www.DataSheet4U.com

UTC assumes no responsibility for equipment failures that result from using products at values that exceed, even momentarily, rated values (such as maximum ratings, operating condition ranges, or other parameters) listed in products specifications of any and all UTC products described or contained herein. UTC products are not designed for use in life support appliances, devices or systems where malfunction of these products can be reasonably expected to result in personal injury. Reproduction in whole or in part is prohibited without the prior written consent of the copyright owner. The information presented in this document does not form part of any quotation or contract, is believed to be accurate and reliable and may be changed without notice.

