



7N70

Power MOSFET

7 Amps, 700 Volts N-CHANNEL POWER MOSFET

DESCRIPTION

The UTC 7N70 is a high voltage MOSFET and is designed to have better characteristics, such as fast switching time, low gate charge, low on-state resistance and have a high rugged avalanche characteristics. This power MOSFET is usually used at high speed switching applications in power supplies, PWM motor controls, high efficient DC to DC converters and bridge circuits.

FEATURES

- * $R_{DS(ON)} = 1.5\Omega @ V_{GS} = 10V$
- * Ultra low gate charge (typical 30 nC)
- * Low reverse transfer capacitance ($C_{RSS} =$ typical 18 pF)
- * Fast switching capability
- * Avalanche energy specified
- * Improved dv/dt capability, high ruggedness

SYMBOL

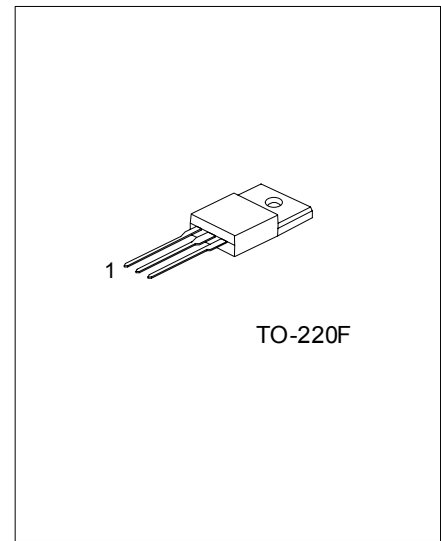
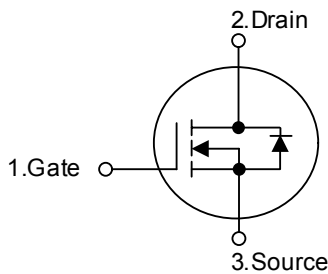

*Pb-free plating product number: 7N70L

ORDERING INFORMATION

| Order Number | | Package | Pin Assignment | | | Packing |
|--------------|-------------------|---------|----------------|---|---|---------|
| Normal | Lead Free Plating | | 1 | 2 | 3 | |
| 7N70-TF3-T | 7N70L-TF3-T | TO-220F | G | D | S | Tube |

| | | |
|--------------------|---|---|
| <p>7N70L-TF3-T</p> | <p>(1) Packing Type</p> <p>(2) Package Type</p> <p>(3) Lead Plating</p> | <p>(1) T: Tube</p> <p>(2) TF3: TO-220F</p> <p>(3) L: Lead Free Plating Blank: Pb/Sn</p> |
|--------------------|---|---|

■ ABSOLUTE MAXIMUM RATINGS ($T_C = 25$, unless otherwise specified)

| PARAMETER | SYMBOL | RATINGS | UNIT |
|---|-----------|---------------------------|------|
| Drain-Source Voltage | V_{DSS} | 700 | V |
| Gate-Source Voltage | V_{GSS} | ± 30 | V |
| Continuous Drain Current | I_D | $T_C = 25^\circ\text{C}$ | 7.0 |
| | | $T_C = 100^\circ\text{C}$ | 4.7 |
| Drain Current Pulsed (Note 1) | I_{DM} | 28 | A |
| Avalanche Energy, Single Pulsed (Note 2) | E_{AS} | 530 | mJ |
| Avalanche Energy, Repetitive, Limited by T_{JMAX} | E_{AR} | 14.2 | mJ |
| Peak Diode Recovery dv/dt (Note 3) | dv/dt | 4.5 | V/ns |
| Power Dissipation ($T_C = 25^\circ\text{C}$) | P_D | 142 | W |
| Junction Temperature | T_J | +150 | |
| Storage Temperature | T_{STG} | -55 ~ +150 | |

Note Absolute maximum ratings are those values beyond which the device could be permanently damaged. Absolute maximum ratings are stress ratings only and functional device operation is not implied.

■ THERMAL DATA

| PARAMETER | SYMBOL | MIN | TYP | MAX | UNIT |
|---------------------|---------------|-----|-----|------|--------------------|
| Junction-to-Ambient | θ_{JA} | | | 62.5 | $^\circ\text{C/W}$ |
| Junction-to-Case | θ_{JC} | | | 0.88 | $^\circ\text{C/W}$ |

■ ELECTRICAL CHARACTERISTICS ($T_C = 25$, unless otherwise specified)

| PARAMETER | SYMBOL | TEST CONDITIONS | MIN | TYP | MAX | UNIT |
|---|----------------|--|-----|------|------|---------------|
| OFF Characteristics | | | | | | |
| Drain-Source Breakdown Voltage | BV_{DSS} | $V_{GS} = 0\text{ V}, I_D = 250\ \mu\text{A}$ | 700 | | | V |
| Drain-Source Leakage Current | I_{DSS} | $V_{DS} = 700\text{ V}, V_{GS} = 0\text{ V}$ | | | 1 | μA |
| | | $V_{DS} = 560\text{ V}, T_C = 125^\circ\text{C}$ | | | 1 | μA |
| Gate-Source Leakage Current | Forward | I_{GSS} | | | | 100 |
| | Reverse | | | | | -100 |
| Breakdown Voltage Temperature Coefficient | BV_{DSS}/T_J | $I_D = 250\ \mu\text{A}$, Referenced to 25°C | | 0.67 | | V/ |
| ON Characteristics | | | | | | |
| Gate Threshold Voltage | $V_{GS(TH)}$ | $V_{DS} = V_{GS}, I_D = 250\ \mu\text{A}$ | 2.0 | | 4.0 | V |
| Drain-Source ON-State Resistance | $R_{DS(ON)}$ | $V_{GS} = 10\text{ V}, I_D = 3.5\text{ A}$ | | 1.35 | 1.5 | Ω |
| Forward Transconductance | g_{FS} | $V_{DS} = 40\text{ V}, I_D = 3.5\text{ A}$ (Note 4) | | 8.0 | | S |
| Dynamic Characteristics | | | | | | |
| Input Capacitance | C_{ISS} | $V_{DS} = 25\text{ V}, V_{GS} = 0\text{ V}, f = 1\text{ MHz}$ | | 1200 | 1600 | pF |
| Output Capacitance | C_{OSS} | | | 150 | 190 | pF |
| Reverse Transfer Capacitance | C_{RSS} | | | 18 | 25 | pF |
| Switching Characteristics | | | | | | |
| Turn-on Delay Time | $t_{D(ON)}$ | $V_{DD} = 350\text{ V}, I_D = 7.0\text{ A}$ (Note 4, 5) | | 35 | 80 | ns |
| Turn-on Rise Time | t_R | | | 79 | 165 | ns |
| Turn-off Delay Time | $t_{D(OFF)}$ | | | 80 | 160 | ns |
| Turn-off Fall Time | t_F | | | 52 | 120 | ns |
| Total Gate Charge | Q_G | $V_{DS} = 560\text{ V}, I_D = 7.0\text{ A}, V_{GS} = 10\text{ V}$ (Note 4, 5) | | 30 | | nC |
| Gate-Source Charge | Q_{GS} | | | 6.5 | | nC |
| Gate-Drain Charge | Q_{DD} | | | 13 | | nC |

■ ELECTRICAL CHARACTERISTICS(Cont.)

| PARAMETER | SYMBOL | TEST CONDITIONS | MIN | TYP | MAX | UNIT |
|--|----------|---|-----|-----|-----|---------------|
| Source- Drain Diode Ratings and Characteristics | | | | | | |
| Drain-Source Diode Forward Voltage | V_{SD} | $V_{GS} = 0\text{ V}, I_S = 7.0\text{ A}$ | | | 1.4 | V |
| Maximum Continuous Drain-Source Diode Forward Current | I_S | | | | 7.0 | A |
| Maximum Pulsed Drain-Source Diode Forward Current | I_{SM} | | | | 28 | A |
| Reverse Recovery Time | t_{RR} | $V_{GS} = 0\text{ V}, I_S = 7.0\text{ A},$ | | 320 | | ns |
| Reverse Recovery Charge | Q_{RR} | $di_F/dt = 100\text{ A}/\mu\text{s}$ (Note 4) | | 2.4 | | μC |

- Notes: 1. Repetitive Rating : Pulse width limited by T_J
 2. $L = 19.5\text{mH}, I_{AS} = 7.0\text{A}, V_{DD} = 50\text{V}, R_G = 0\ \Omega$, Starting $T_J = 25^\circ\text{C}$
 3. $I_{SD} \leq 7.0\text{A}, di/dt \leq 100\text{A}/\mu\text{s}, V_{DD} \leq BV_{DSS}$, Starting $T_J = 25^\circ\text{C}$
 4. Pulse Test: Pulse width $\leq 300\mu\text{s}$, Duty cycle $\leq 2\%$
 5. Essentially independent of operating temperature

■ TEST CIRCUITS AND WAVEFORMS

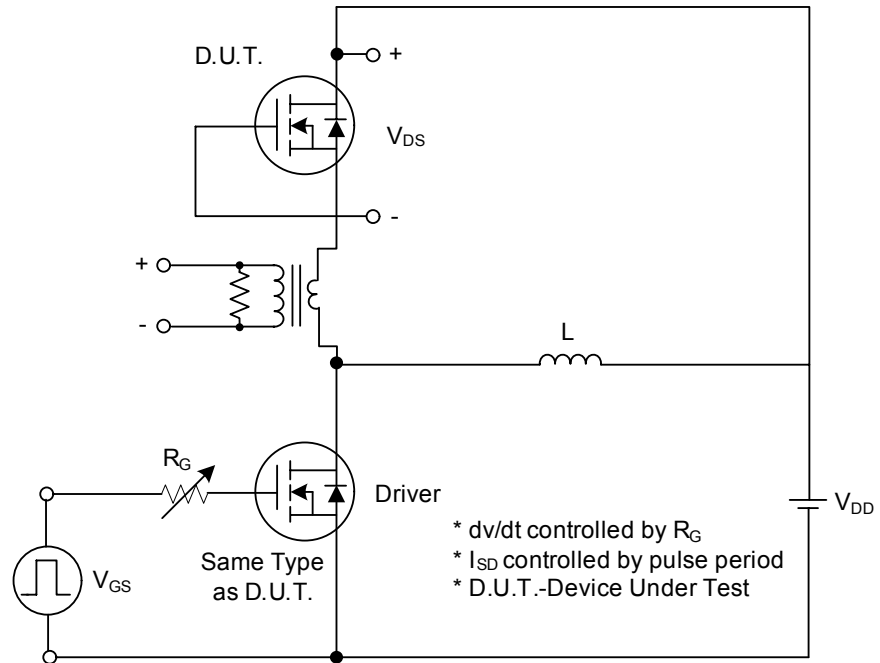

Fig. 1A Peak Diode Recovery dv/dt Test Circuit

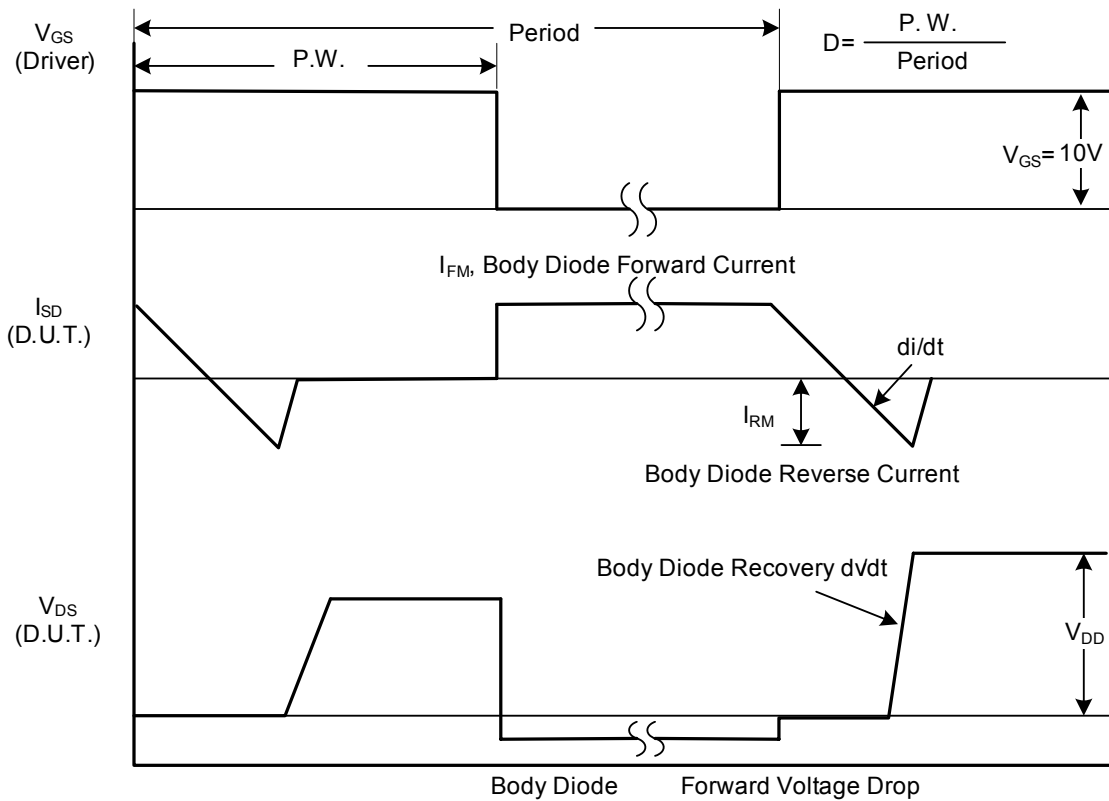

Fig. 1B Peak Diode Recovery dv/dt Waveforms

■ TEST CIRCUITS AND WAVEFORMS (Cont.)

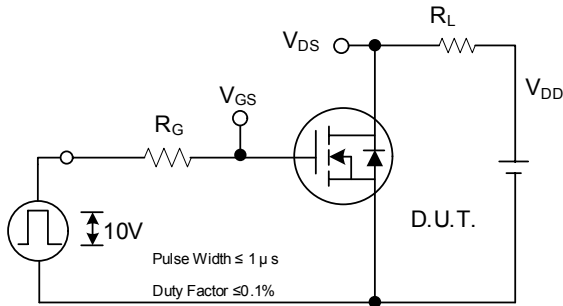

Fig. 2A Switching Test Circuit

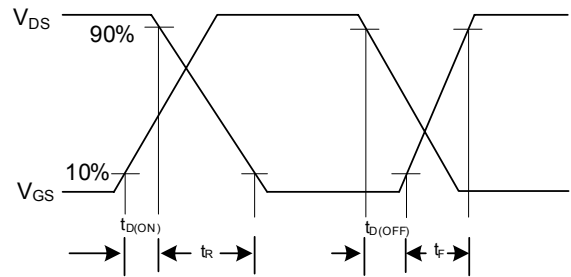

Fig. 2B Switching Waveforms

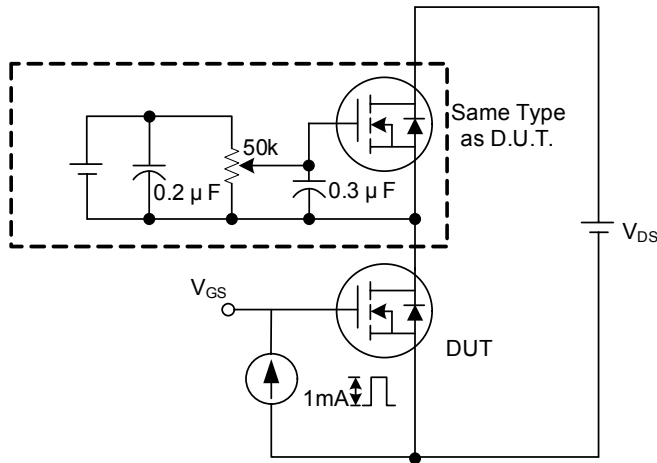

Fig. 3A Gate Charge Test Circuit

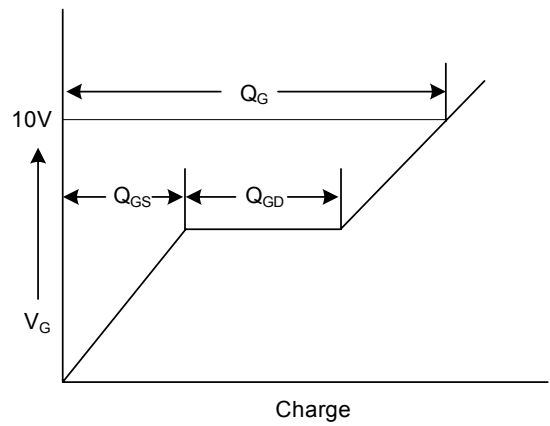

Fig. 3B Gate Charge Waveform

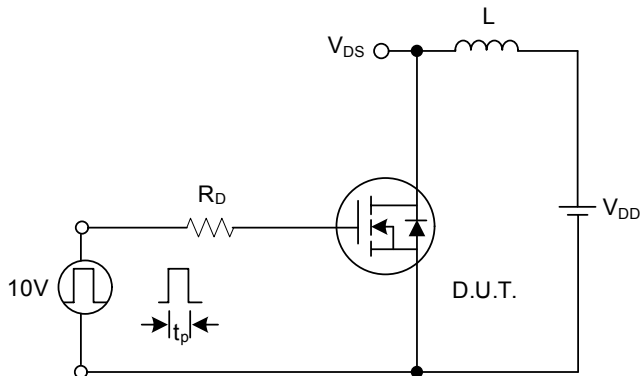

Fig. 4A Unclamped Inductive Switching Test Circuit

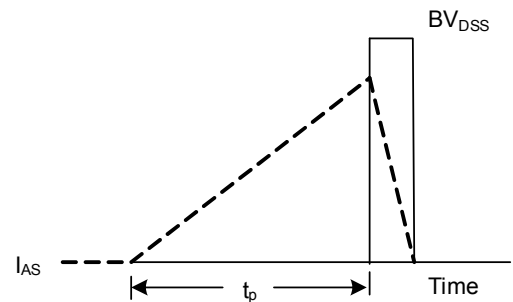
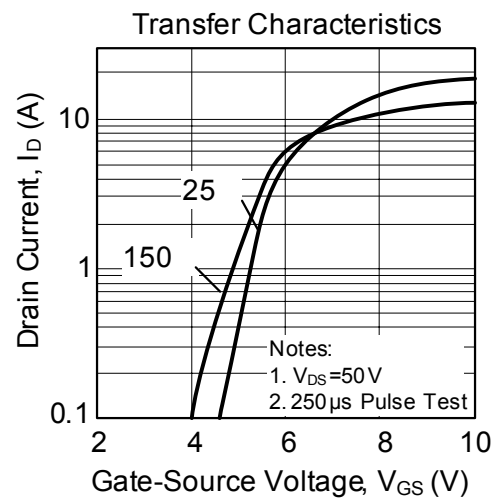
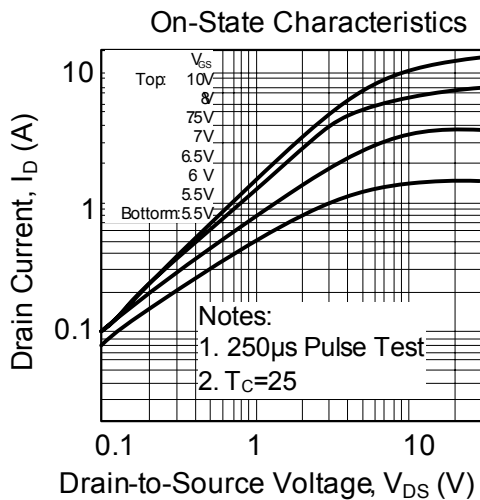
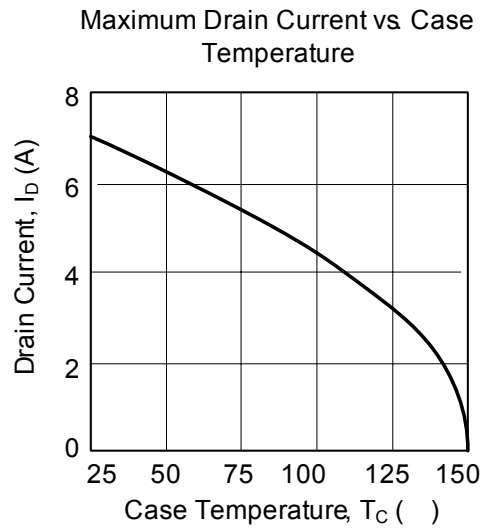
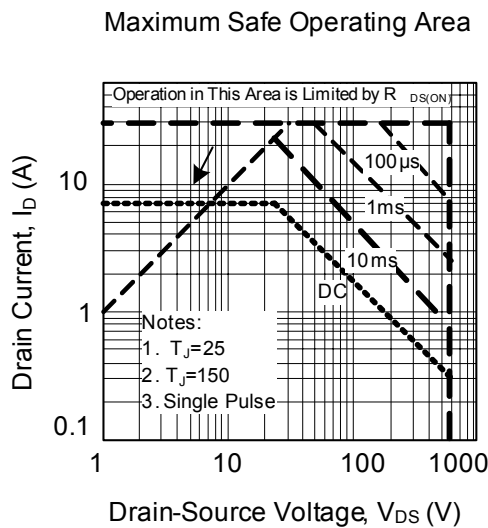
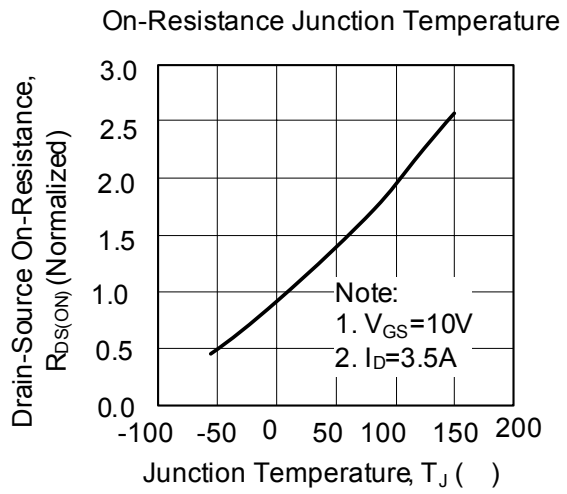
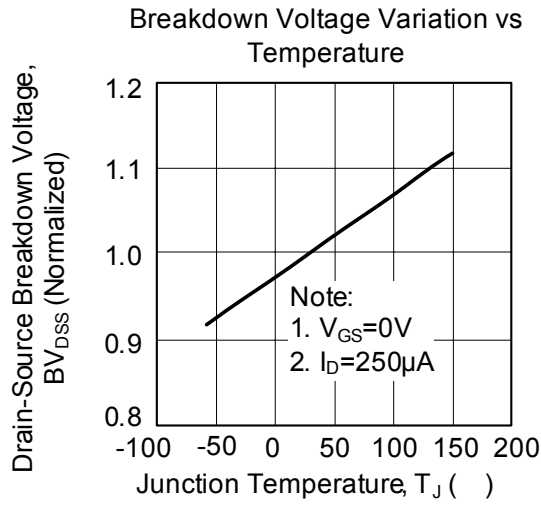

Fig. 4B Unclamped Inductive Switching Waveforms

■ TYPICAL CHARACTERISTICS



■ TYPICAL CHARACTERISTICS(Cont.)

On-Resistance Variation vs Drain Current and Gate Voltage

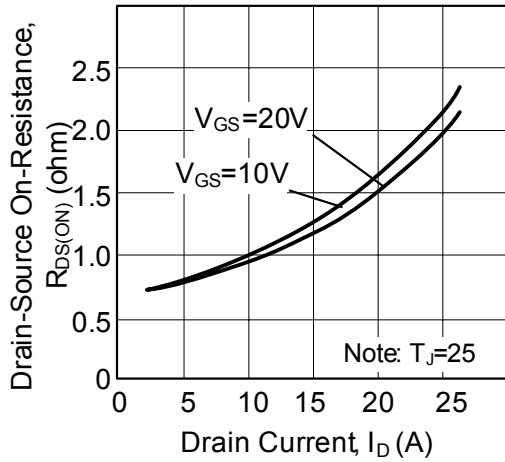

On State Current vs. Allowable Case Temperature

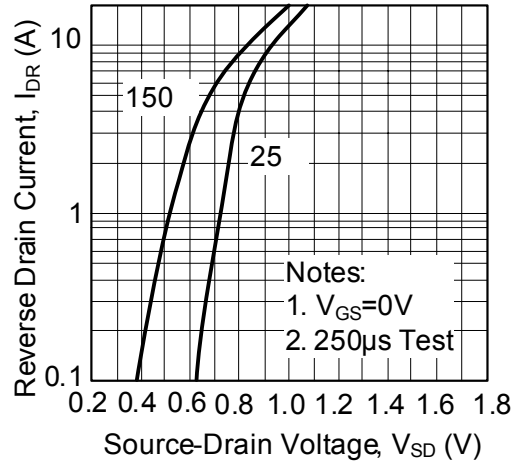

Capacitance Characteristics (Non-Repetitive)

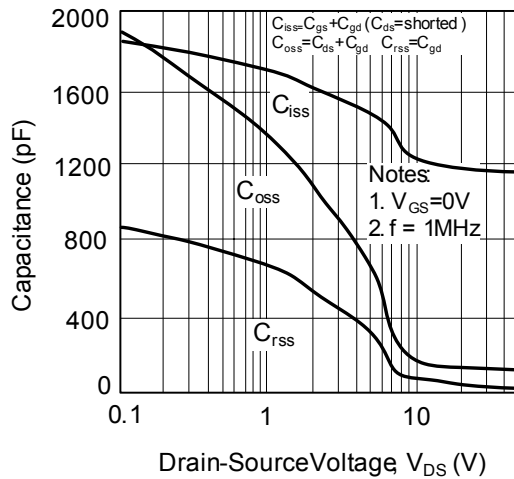

Gate Charge Characteristics

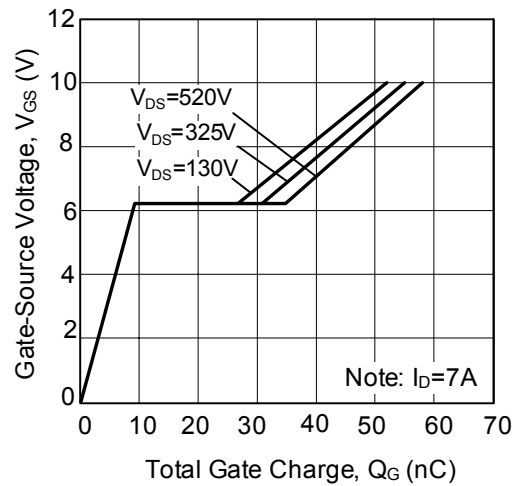

Transient Thermal Response Curve

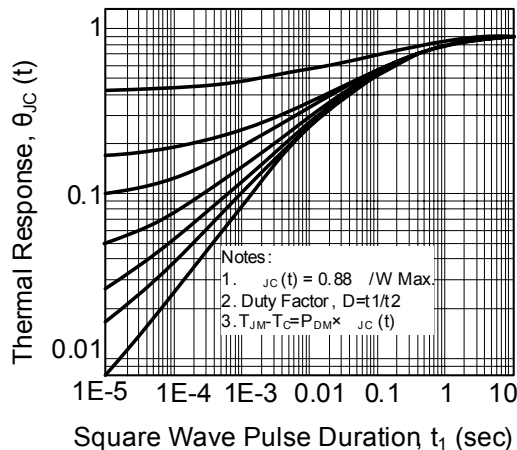

UTC assumes no responsibility for equipment failures that result from using products at values that exceed, even momentarily, rated values (such as maximum ratings, operating condition ranges, or other parameters) listed in products specifications of any and all UTC products described or contained herein. UTC products are not designed for use in life support appliances, devices or systems where malfunction of these products can be reasonably expected to result in personal injury. Reproduction in whole or in part is prohibited without the prior written consent of the copyright owner. The information presented in this document does not form part of any quotation or contract, is believed to be accurate and reliable and may be changed without notice.