

## Silicon PNP Power Transistors

## 2SA1216

**DESCRIPTION**

- With MT-200 package
- Complement to type 2SC2922

**APPLICATIONS**

- Audio and general purpose

**PINNING(see Fig.2)**

PIN	DESCRIPTION
1	Base
2	Collector;connected to mounting base
3	Emitter

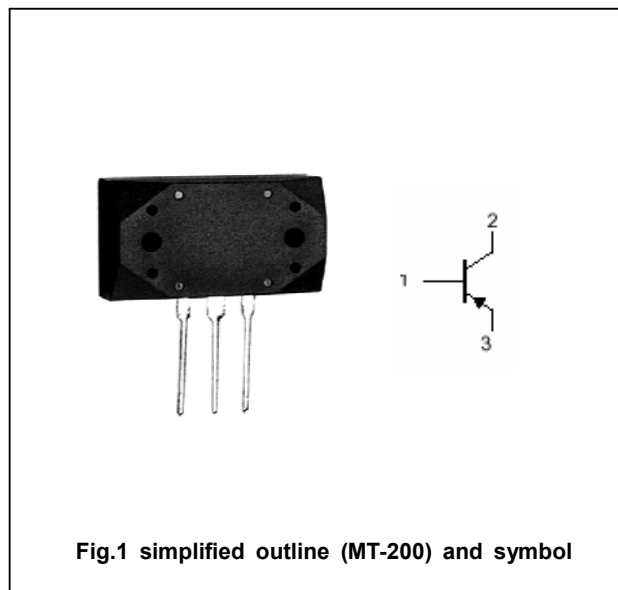
**Absolute maximum ratings(Ta=25℃)**

SYMBOL	PARAMETER	CONDITIONS	VALUE	UNIT
V <sub>CBO</sub>	Collector-base voltage	Open emitter	-180	V
V <sub>CEO</sub>	Collector-emitter voltage	Open base	-180	V
V <sub>EBO</sub>	Emitter-base voltage	Open collector	-5	V
I <sub>C</sub>	Collector current		-17	A
I <sub>B</sub>	Base current		-5	A
P <sub>C</sub>	Collector power dissipation	T <sub>C</sub> =25℃	200	W
T <sub>j</sub>	Junction temperature		150	℃
T <sub>stg</sub>	Storage temperature		-55~150	℃

## Silicon PNP Power Transistors

## 2SA1216

## CHARACTERISTICS

T<sub>j</sub>=25°C unless otherwise specified

SYMBOL	PARAMETER	CONDITIONS	MIN	TYP.	MAX	UNIT
V <sub>(BR)CEO</sub>	Collector-emitter breakdown voltage	I <sub>C</sub> =-25mA ; I <sub>B</sub> =0	-180			V
V <sub>CEsat</sub>	Collector-emitter saturation voltage	I <sub>C</sub> =-8A ; I <sub>B</sub> =-0.8A			-2.0	V
I <sub>CBO</sub>	Collector cut-off current	V <sub>CB</sub> =-180V ; I <sub>E</sub> =0			-100	μA
I <sub>EBO</sub>	Emitter cut-off current	V <sub>EB</sub> =-5V ; I <sub>C</sub> =0			-100	μA
h <sub>FE</sub>	DC current gain	I <sub>C</sub> =-8A ; V <sub>CE</sub> =-4V	30			
C <sub>ob</sub>	Output capacitance	I <sub>E</sub> =0 ; V <sub>CB</sub> =-10V ; f=1MHz		500		pF
f <sub>T</sub>	Transition frequency	I <sub>C</sub> =-2A ; V <sub>CE</sub> =-12V		40		MHz

## Switching times

t <sub>on</sub>	Turn-on time	I <sub>C</sub> =-10A ; R <sub>L</sub> =Ω I <sub>B1</sub> =-I <sub>B2</sub> =-1A V <sub>CC</sub> =-40V		0.30		μs
t <sub>s</sub>	Storage time			0.70		μs
t <sub>f</sub>	Fall time			0.20		μs

◆ h<sub>FE</sub> classifications

O	Y	P	G
30-60	50-100	70-140	90-180

## Silicon PNP Power Transistors

2SA1216

## PACKAGE OUTLINE

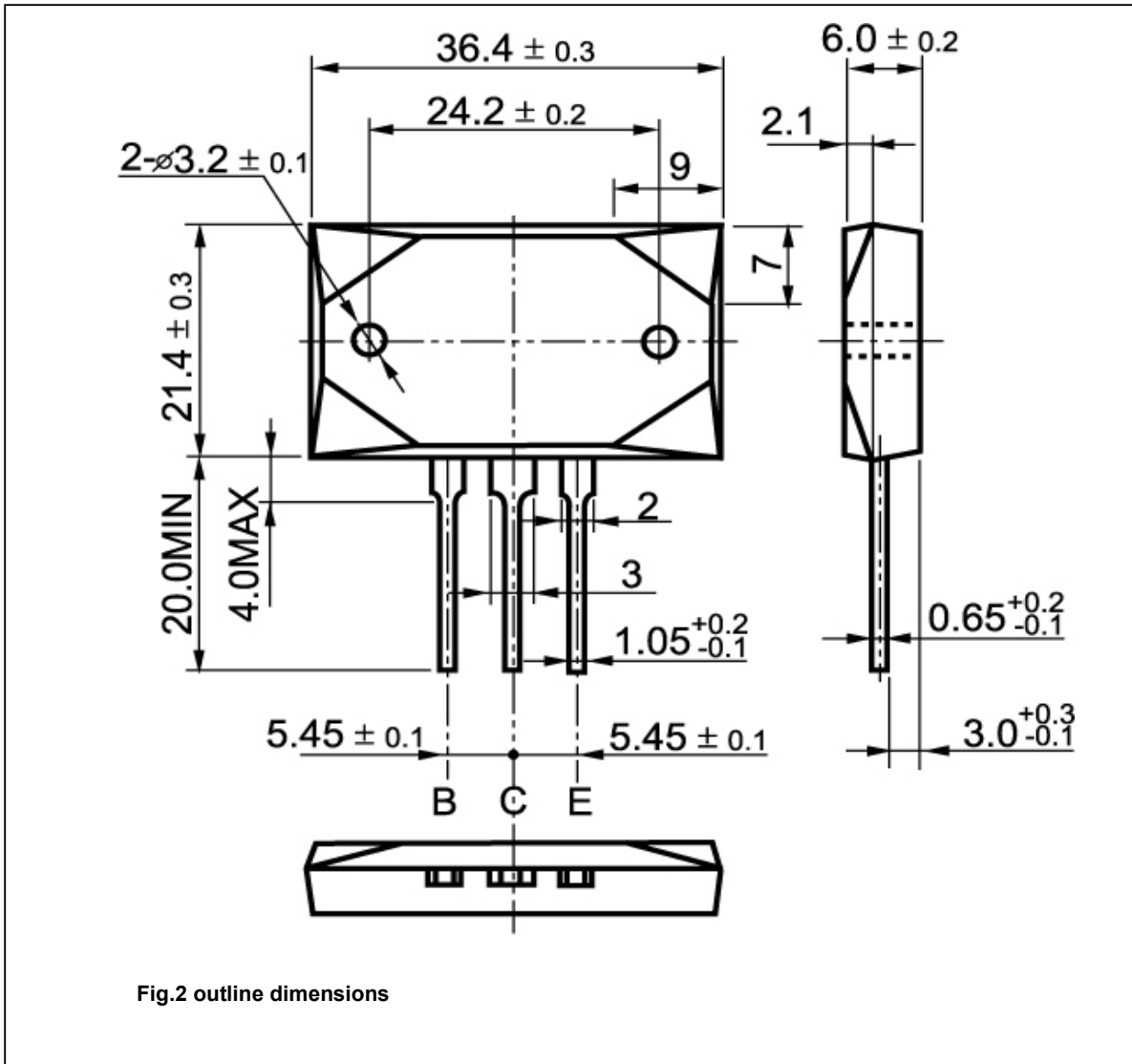

Silicon PNP Power Transistors

2SA1216

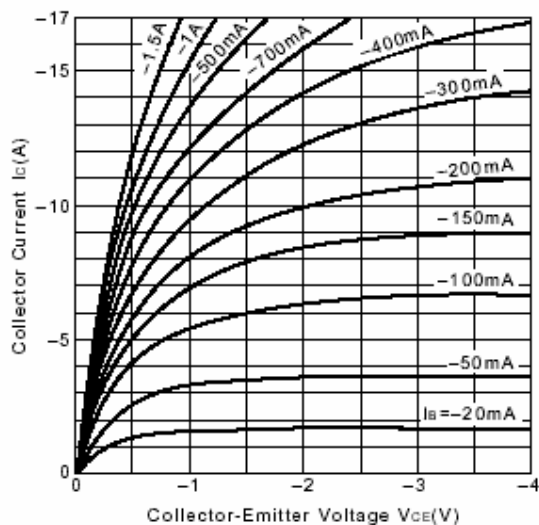

Fig.3 Static Characteristic

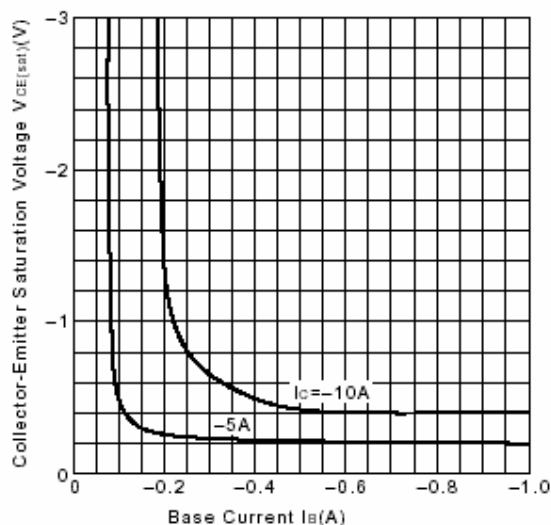

Fig.4  $V_{CE(sat)}$ - $I_B$  Characteristics

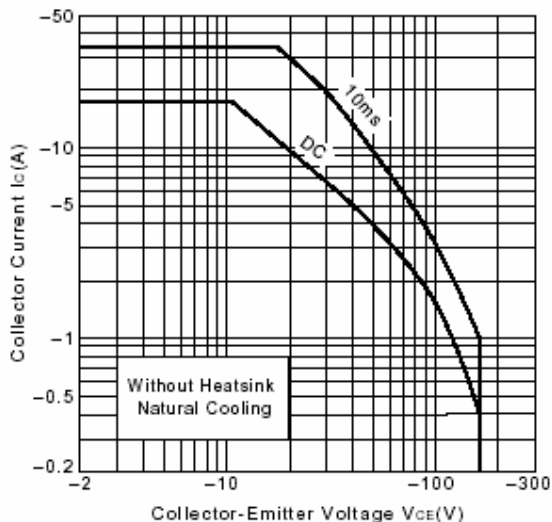

Fig.5 Safe Operating Area

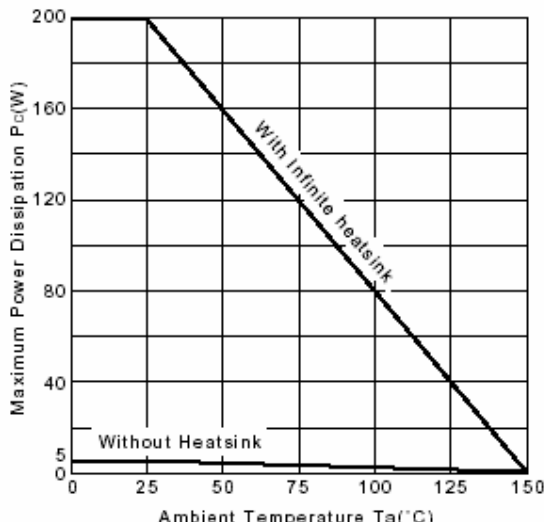

Fig.6  $P_c$ - $T_a$  Derating

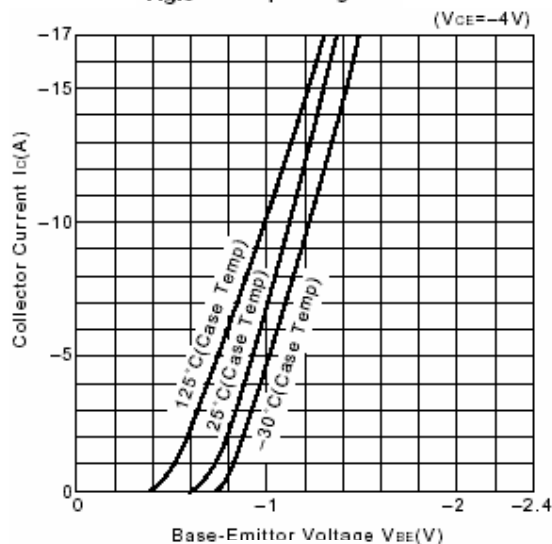

Fig.7  $I_C$ - $V_{BE}$

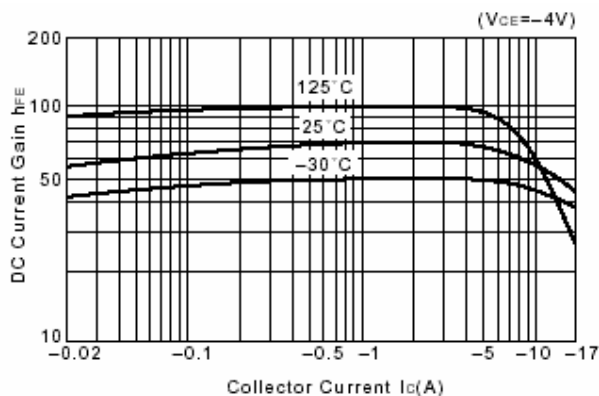

Fig.8 DC current Gain