

SEMICONDUCTOR SELECTION GUIDE

GUIDE BOOK

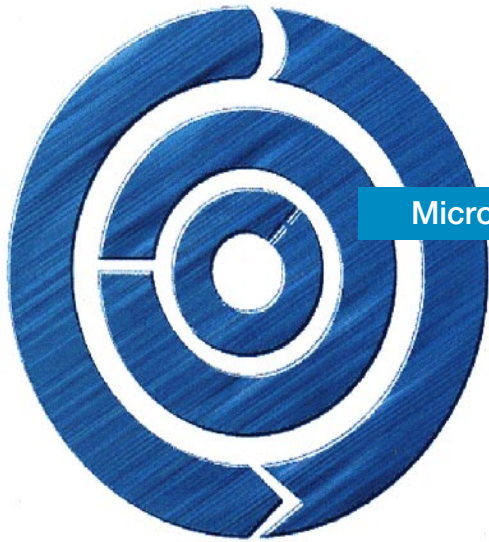

Microcomputer 1

IC Memory 2

Semi-Custom IC 3

Particular Purpose IC 4

General Purpose Linear IC 5

Transistor / Diode / Thyristor 6

Microwave Device / Consumer Use High Frequency Device 7

Optical Device 8

Packages 9

Index (Quick Reference by Type Number) 10

Oct. 1995

Microcomputer

4-Bit Single Chip Microcomputer	2
• 75XL Series	2
• 75X Series	8
• μPD7500 Series	17
• 17K Series	18
• μPD1700 Series	23
• μPD6133 Series	24
8-Bit Single Chip Microcomputer	26
• 87AD Series	26
8/16-Bit Single Chip Microcomputer	28
• 78K Series	28
V Series™	54
• 16-Bit.....	54
• 32-Bit.....	57
• 32-Bit RISC – V800 Series –	58
V_R Series™	60
Microcomputer Peripheral LSI.....	61

4-Bit Single Chip Microcomputer

75XL Series

■ **75XL series product evolution**

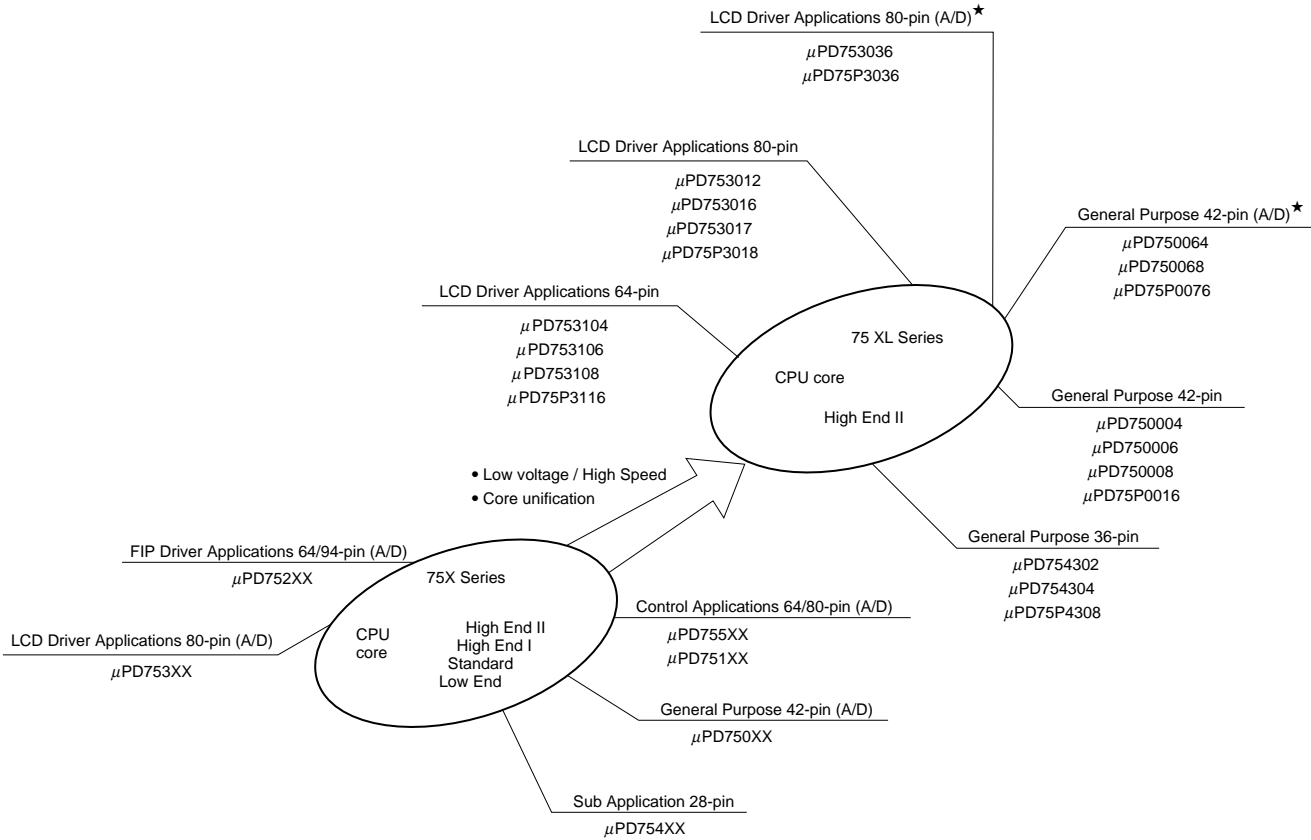

★ : Under development

4-Bit Single Chip Microcomputer

General Purpose Series

■ μ PD750008 series

Type number		μ PD750004/0006/0008	μ PD75P0016
ROM (bytes)		4096/6144/8192	16384 (PROM)
RAM (∞ 4 bits)		512	
General registers		(4-bit ∞ 8) ∞ 4 banks or (8-bit ∞ 4) ∞ 4 banks	
Instruction cycle		Selectable from 0.95 μ s/1.91 μ s/3.81 μ s/15.3 μ s (at main clock 4.19 MHz), 0.67 μ s/1.33 μ s/2.67 μ s/10.7 μ s (at main clock 6.0 MHz) and 122 μ s (at subclock 32 kHz)	
Input/ output ports	CMOS inputs	8 (also serve as INT, SIO)	Can be pulled up by software except P00
	CMOS inputs/outputs	18 (can drive LED)	
	N-ch inputs/outputs	8 (can drive LED, withstand voltage 12 V, can be pulled up by mask option except PROM version)	
Timer/Counters		4 channels • Timer/event counter • Basic interval timer/watchdog timer • Watch timer • 8-bit timer	
Serial interface		NEC standard serial bus interface/3-line serial interface	
Interrupts		• Vector interrupts: 7 (external: 3, internal: 4), • Test inputs: 2 (external: 1, internal: 1)	
Clock output (PCL)		• Φ , 524 kHz, 262 kHz, 65.5 kHz (Main system clock: 4.19 MHz) • Φ , 750 kHz, 375 kHz, 93.7 kHz (Main system clock: 6.0 MHz)	
Buzzer output (BUZ)		• 2 kHz, 4 kHz, 32 kHz (Main system clock: 4.19 MHz or subsystem clock: 32.768 kHz) • 2.86 kHz, 5.72 kHz, 45.8 kHz (Main system clock: 6.0 MHz)	
Instruction set		• Bit data set/reset/test/boolean operation instructions • 4/8-bit data transfer/operation/increment/decrement/compare instructions	
Supply voltage		2.2 to 5.5 V (when external clock used VDD = 1.8 to 5.5 V)	
Package		• 42-pin plastic SDIP, • 44-pin plastic QFP	

■ μ PD754304 series

Type number		μ PD754302/4304	μ PD75P4308
ROM (bytes)		2048/4096	8192 (PROM)
RAM (∞ 4 bits)		256	
General registers		(4-bit ∞ 8) ∞ 4 banks or (8-bit ∞ 4) ∞ 4 banks	
Instruction cycle		Selectable from 0.95 μ s/1.91 μ s/3.81 μ s/15.3 μ s (at main clock 4.19 MHz), 0.67 μ s/1.33 μ s/2.67 μ s/10.7 μ s (at main clock 6.0 MHz)	
Input/ output ports	CMOS inputs	8 (also serve as INT, SIO)	Can be pulled up by software except P00
	CMOS inputs/outputs	18 (4 can drive LED)	
	N-ch inputs/outputs	4 (can drive LED, withstand voltage 12 V, can be pulled up by mask option except PROM version)	
Timer/Counters		3 channels • Timer/event counter ∞ 2 ch. (Applicable at a 16-bit Timer/Event counter by Cascade connection) • Basic interval timer, • Watchdog timer	
Serial interface		2-line/3-line serial interface	
Interrupts		• Vector interrupts: 7 (external: 3, internal: 4), • Test inputs: 1 (external: 1)	
Clock output (PCL)		• Φ , 524 kHz, 262 kHz, 65.5 kHz (Main system clock: 4.19 MHz) • Φ , 750 kHz, 375 kHz, 93.7 kHz (Main system clock: 6.0 MHz)	
Instruction set		• Bit data set/reset/test/boolean operation instructions • 4/8-bit data transfer/operation/increment/decrement/compare instructions	
Supply voltage		1.8 to 5.5 V	
Package		• 36-pin plastic SSOP (300 mil, 0.8 mm pitch)	

4-Bit Single Chip Microcomputer

General Purpose Series

■ μ PD750068 series

Type number	μ PD750064 [★] /0068 [★]	μ PD75P0076 [★]
ROM (bytes)	4096/8192	16384 (PROM)
RAM (∞ 4 bits)	512	
General registers	(4-bit ∞ 8) ∞ 4 banks or (8-bit ∞ 4) ∞ 4 banks	
Instruction cycle	Selectable from 0.95 μ s/1.91 μ s/3.81 μ s/15.3 μ s (at main clock 4.19 MHz), 0.67 μ s/1.33 μ s/2.67 μ s/10.7 μ s (at main clock 6.0 MHz) and 122 μ s (at subclock 32 kHz)	
Input/ output ports	CMOS inputs	12 (also serve as INT, SIO)
	CMOS inputs/outputs	12 (can drive LED)
	N-ch inputs/outputs	8 (can drive LED, withstand voltage 12 V, can be pulled up by mask option except PROM version)
A/D converter	• 8-bit ∞ 8 ch	
Timer/Counters	4 channels • Timer/event counter ∞ 2 ch. (Applicable at a 16-bit Timer/Event counter by Cascade connection) • Basic interval timer/watchdog timer • Watch timer	
Serial interface	2-line/3-line serial interface	
Interrupts	• Vector interrupts: 7 (external: 3, internal: 4), • Test inputs: 2 (external: 1, internal: 1)	
Clock output (PCL)	• Φ , 524 kHz, 262 kHz, 65.5 kHz (Main system clock: 4.19 MHz) • Φ , 750 kHz, 375 kHz, 93.7 kHz (Main system clock: 6.0 MHz)	
Buzzer output (BUZ)	• 2 kHz, 4 kHz, 32 kHz (Main system clock: 4.19 MHz or subsystem clock: 32.768 kHz) • 2.86 kHz, 5.72 kHz, 45.8 kHz (Main system clock: 6.0 MHz)	
Instruction set	• Bit data set/reset/test/boolean operation instructions • 4/8-bit data transfer/operation/increment/decrement/compare instructions	
Supply voltage	1.8 to 5.5 V	
Package	• 42-pin plastic SDIP, • 44-pin plastic QFP	

★: Under development

4-Bit Single Chip Microcomputer
--

LCD Driver Series

■ μ PD753017 series

Type number	μ PD753012	μ PD753016	μ PD753017	μ PD75P3018
ROM (bytes)	12288	16384	24576	32768 (PROM)
RAM (∞ 4 bits)	1024			
General registers	(4-bit ∞ 8) ∞ 4 banks or (8-bit ∞ 4) ∞ 4 banks			
Instruction cycle	Selectable from 0.95 μ s/1.91 μ s/3.81 μ s/15.3 μ s (at main clock 4.19 MHz) , 0.67 μ s/1.33 μ s/2.67 μ s/10.7 μ s (at main clock 6.0 MHz) and 122 μ s (at subclock 32 kHz)			
Input/ output ports	CMOS inputs	40	8 (also serve as INT, SIO)	Can be pulled up by software except P00
	CMOS inputs/outputs		16 (can drive LED)	
	N-ch inputs/outputs		8 (can drive LED, withstand voltage 12 V, can be pulled up by mask option except PROM version)	
	CMOS outputs		4/8 (also serve as segment outputs, selection by software)	
LCD controller	<ul style="list-style-type: none"> • Segment outputs: 32 ∞ 4 (MAX.), • Display mode (static, 1/2, 1/3, 1/4 duty) • LCD drive voltage generation step down register (except PROM version) 			
Timer/Counters	5 channels • Timer/event counter ∞ 3 ch. (Applicable as a 16-bit Timer/Event counter by Cascade connection, Infrared remote control carrier generator) <ul style="list-style-type: none"> • Basic interval timer/watchdog timer • Watch timer 			
Serial interface	NEC standard serial bus interface/3-line serial interface			
Interrupts	<ul style="list-style-type: none"> • Vector interrupts: 8 (external: 3, internal: 5), • Test inputs: 2 (external: 1, internal: 1) 			
Clock output (PCL)	<ul style="list-style-type: none"> • Φ, 524 kHz, 262 kHz, 65.5 kHz (Main system clock: 4.19 MHz) • Φ, 750 kHz, 375 kHz, 93.7 kHz (Main system clock: 6.0 MHz) 			
Buzzer output (BUZ)	<ul style="list-style-type: none"> • 2 kHz, 4 kHz, 32 kHz (Main system clock: 4.19 MHz or subsystem clock: 32.768 kHz) • 2.86 kHz, 5.72 kHz, 45.8 kHz (Main system clock: 6.0 MHz) 			
Instruction set	<ul style="list-style-type: none"> • Bit data set/reset/test/boolean operation instructions • 4/8-bit data transfer/operation/increment/decrement/compare instructions • 8-bit data transfer instructions 			
Supply voltage	2.2 to 5.5 V (when External clock used $V_{DD} = 1.8$ to 5.5 V)			
Package	• 80-pin plastic QFP (0.5/0.65 mm pitch)			

4-Bit Single Chip Microcomputer

LCD Driver Series

■ μ PD753108 series

Type number		μ PD753104	μ PD753106	μ PD753108	μ PD75P3116	
ROM (bytes)		4096	6144	8192	16384 (PROM)	
RAM (∞ 4 bits)		512				
General registers		(4-bit ∞ 8) ∞ 4 banks or (8-bit ∞ 4) ∞ 4 banks				
Instruction cycle		Selectable from 0.95 μ s/1.91 μ s/3.81 μ s/15.3 μ s (at main clock 4.19 MHz) , 0.67 μ s/1.33 μ s/2.67 μ s/10.7 μ s (at main clock 6.0 MHz) and 122 μ s (at subclock 32 kHz)				
Input/ output ports	CMOS inputs	32	8 (also serve as INT, SIO)	Can be pulled up by software except P00		
	CMOS inputs/outputs		12 (4 can drive LED)			
	N-ch inputs/outputs		4 (can drive LED, withstand voltage 12 V, can be pulled up by mask option except PROM version)			
	CMOS outputs		8 (also serve as segment outputs, selection by software)			
LCD controller		<ul style="list-style-type: none"> • Segment outputs: 24 ∞ 4 (MAX.) • Display mode (static, 1/2, 1/3, 1/4 duty) • LCD drive voltage generation step down register (except PROM version) 				
Timer/Counters		5 channels • Timer/event counter ∞ 3 ch. (Applicable as a 16-bit Timer/Event counter by Cascade connection, Infrared remote control carrier generator) <ul style="list-style-type: none"> • Basic interval timer/watchdog timer • Watch timer 				
Serial interface		NEC standard serial bus interface/3-line serial interface				
Interrupts		<ul style="list-style-type: none"> • Vector interrupts: 6 (external: 3, internal: 3) • Test inputs: 2 (external: 1, internal: 1) 				
Clock output (PCL)		<ul style="list-style-type: none"> • Φ, 524 kHz, 262 kHz, 65.5 kHz (Main system clock: 4.19 MHz) • Φ, 750 kHz, 375 kHz, 93.7 kHz (Main system clock: 6.0 MHz) 				
Buzzer output (BUZ)		<ul style="list-style-type: none"> • 2 kHz, 4 kHz, 32 kHz (Main system clock: 4.19 MHz or subsystem clock: 32.768 kHz) • 2.86 kHz, 5.72 kHz, 45.8 kHz (Main system clock: 6.0 MHz) 				
Instruction set		<ul style="list-style-type: none"> • Bit data set/reset/test/boolean operation instructions • 4-bit data transfer/operation/increment/decrement/compare instructions • 8-bit data transfer instructions 				
Supply voltage		1.8 to 5.5 V				
Package		• 64-pin plastic QFP (0.65/0.8 mm pitch)				

4-Bit Single Chip Microcomputer

LCD Driver Series

■ μ PD753036 series

Type number	μ PD753036 [★]	μ PD75P3036 [★]
ROM (bytes)	16384	16384 (PROM)
RAM (∞ 4 bits)	768	
General registers	(4-bit ∞ 8) ∞ 4 banks or (8-bit ∞ 4) ∞ 4 banks	
Instruction cycle	Selectable from 0.95 μ s/1.91 μ s/3.81 μ s/15.3 μ s (at main clock 4.19 MHz) , 0.67 μ s/1.33 μ s/2.67 μ s/10.7 μ s (at main clock 6.0 MHz) and 122 μ s (at subclock 32 kHz)	
Input/ output ports	CMOS inputs	44 Can be pulled up by software except P00
	CMOS inputs/outputs	
	N-ch inputs/outputs	
	CMOS outputs	
A/D converter	• 8-bit ∞ 8 ch	
LCD controller	<ul style="list-style-type: none"> • Segment outputs: 20 ∞ 4 (MAX.), • Display mode (static, 1/2, 1/3, 1/4 duty) • LCD drive voltage generation step down register (except PROM version) 	
Timer/Counters	5 channels • Timer/event counter ∞ 3 ch. (Applicable as a 16-bit Timer/Event counter by Cascade connection, Infrared remote control carrier generator) <ul style="list-style-type: none"> • Basic interval timer/watchdog timer • Watch timer 	
Serial interface	NEC standard serial bus interface/3-line serial interface	
Interrupts	• Vector interrupts: 8 (external: 3, internal: 5), • Test inputs: 2 (external: 1, internal: 1)	
Clock output (PCL)	<ul style="list-style-type: none"> • Φ, 524 kHz, 262 kHz, 65.5 kHz (Main system clock: 4.19 MHz) • Φ, 750 kHz, 375 kHz, 93.7 kHz (Main system clock: 6.0 MHz) 	
Buzzer output (BUZ)	<ul style="list-style-type: none"> • 2 kHz, 4 kHz, 32 kHz (Main system clock: 4.19 MHz or subsystem clock: 32.768 kHz) • 2.86 kHz, 5.72 kHz, 45.8 kHz (Main system clock: 6.0 MHz) 	
Instruction set	<ul style="list-style-type: none"> • Bit data set/reset/test/boolean operation instructions • 4/8-bit data transfer/operation/increment/decrement/compare instructions • 8-bit data transfer instructions 	
Supply voltage	1.8 to 5.5 V	
Package	• 80-pin plastic QFP (0.5/0.65 mm pitch)	

★: Under development

4-Bit Single Chip Microcomputer

75X Series

■ **75X series product evolution**

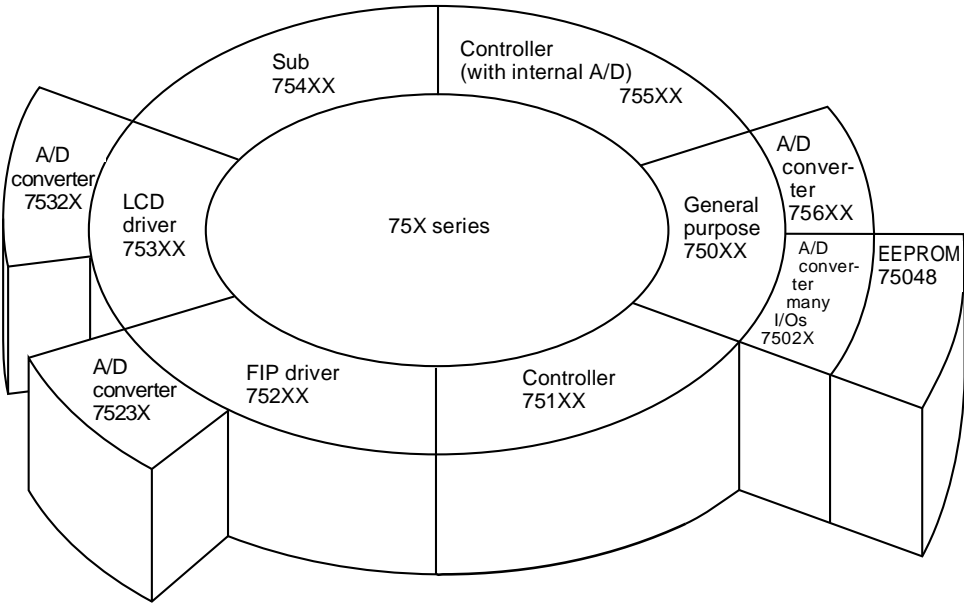

4-Bit Single Chip Microcomputer

Controller Series

■ μ PD751XX series (1/2)

Type number		μ PD75104/106/108/112/116	μ PD75104A/108A	μ PD75108F/112F/116F
ROM (bytes)		4096/6016/8064/12160/16256	4096/8064	8064/12160/16256
RAM (x 4 bits)		320/320/512/512/512	320/512	512
General registers		(4-bit x 8) ∞ 4 banks or (8-bit ∞ 4) ∞ 4 banks		
Instruction cycle		Selectable from 0.95 μ s/1.91 μ s/15.3 μ s (at 4.19 MHz)		
Minimum instruction execution time		0.95 μ s ($V_{DD} = 4.5$ V) 3.81 μ s ($V_{DD} = 2.7$ V)		0.95 μ s ($V_{DD} = 4.5$ V) 1.91 μ s ($V_{DD} = 2.7$ V)
Input/output ports	CMOS inputs	10 (also serve as INT, SIO, 4 can be pulled up at μ PD75104A/108A only)		
	CMOS inputs/outputs	54 32 (capable of driving LED, 24 can be pulled up at μ PD75104A/108A only)		
	N-ch inputs/outputs	12 (capable of driving LED, withstand voltage 12 V, can be pulled up)		
Comparator inputs		4-bit resolution ∞ 4 channels		
Timer/Counters		3 channels • Timer/event counter ∞ 2, • Basic interval timer		
Serial interface		3-line serial interface		
Interrupts		• Vector interrupts: 7 (external: 3, internal: 4), • External test inputs: 2		
Instruction set		• Bit data set/reset/test/boolean operation instructions • 4/8-bit data transfer/operation/increment/decrement/compare instructions		
Supply voltage		2.7 to 6.0 V		2.7 to 5.0 V ($T_a = -40$ to $+50$ °C) 2.8 to 5.0 V ($T_a = -40$ to $+60$ °C)
Package		• 64-pin plastic SDIP • 64-pin plastic QFP (1.0 mm pitch)	• 64-pin plastic QFP (0.8 mm pitch)	• 64-pin plastic QFP (1.0 mm pitch)

■ μ PD751XX series (2/2)

Type number		μ PD75P108B	μ PD75P116	μ PD75116H/117H	μ PD75P117H
ROM (bytes)		8064 (PROM)	16256 (PROM)	16256/24448	24448 (PROM)
RAM (x 4 bits)		512		768	
General registers		(4-bit x 8) ∞ 4 banks or (8-bit ∞ 4) ∞ 4 banks			
Instruction cycle		Selectable from 0.95 μ s/1.91 μ s/15.3 μ s (4.19 MHz)			
Minimum instruction execution time		0.95 μ s ($V_{DD} = 4.5$ V) 3.81 μ s ($V_{DD} = 2.7$ V)	0.95 μ s	0.95 μ s ($V_{DD} = 2.7$ V) 1.91 μ s ($V_{DD} = 1.8$ V)	
Input/output ports	CMOS inputs	10 (also serve as INT, SIO)		10 (also serve as INT, SIO)	
	CMOS inputs/outputs	54 32 (capable of driving LED)		54 32 (8 can drive LED)	
	N-ch inputs/outputs	12 (capable of driving LED, withstand voltage 12 V)		12 (withstand voltage 6 V, can be pulled up except PROM version)	
Comparator inputs		4-bit resolution ∞ 4 channels			
Timer/Counters		3 channels • Timer/event counter ∞ 2, • Basic interval timer			
Serial interface		3-line serial interface			
Interrupts		• Vector interrupts: 7 (external: 3, internal: 4), • External test inputs: 2			
Instruction set		• Bit data set/reset/test/boolean operation instructions • 4/8-bit data transfer/operation/increment/decrement/compare instructions			
Supply voltage		2.7 to 6.0 V	4.5 to 5.5 V	1.8 to 5.5 V ($T_a = -40$ to $+60$ °C)	
Package		• 64-pin ceramic SDIP with window (μ PD75P108B only) • 64-pin plastic SDIP • 64-pin plastic QFP (1.0 mm pitch)		• 64-pin plastic QFP (0.65/0.8 mm pitch) • 64-pin ceramic WQFN (0.8 mm pitch: μ PD75P117H only)	

4-Bit Single Chip Microcomputer

Controller Series

■ μ PD755XX series

Type number		μ PD75512/516	μ PD75P516	μ PD75517/518	μ PD75P518
ROM (bytes)		12160/16256	16256 (PROM)	24448/32640	32640 (PROM)
RAM (∞ 4 bits)		512		1024	
General registers		(4-bit ∞ 8) ∞ 4 banks or (8-bit ∞ 4) ∞ 4 banks			
Instruction cycle		Selectable from 0.95 μ s/1.91 μ s/15.3 μ s (at main clock 4.19 MHz) and 122 μ s (at subclock 32 kHz)		Selectable from 0.67 μ s/1.33 μ s/2.67 μ s/10.7 μ s (at main clock 6 MHz) and 122 μ s (at subclock 32 kHz)	
Input/ output ports	CMOS inputs	64	16 (also serve as INT, SIO, A/D inputs)	7 can be pulled up by software	
	CMOS inputs/outputs		28 (4 can drive LED)	4 can be pulled down by mask option except PROM version 16 can be pulled up by software	
	N-ch inputs/outputs		20 (8 can drive LED, withstand voltage 9 V, can be pulled up by mask option except PROM version)		
A/D converter		8-bit resolution ∞ 8 channels			
Timer/Counters		3 channels • Timer/event counter, • Basic interval timer, • Watch timer			
Serial interface		2 channels • NEC standard serial bus interface/3-line serial interface • 3-line serial interface			
Interrupts		• Vector interrupts: 7 (external: 3, internal: 4), • Test inputs: 2 (external: 1, internal: 1)			
Instruction set		• Bit data set/reset/test/boolean operation instructions • 4/8-bit data transfer/operation/increment/decrement/compare instructions			
Supply voltage		2.7 to 6.0 V	4.75 to 5.5 V	2.7 to 6.0 V	
Package		• 80-pin plastic QFP	• 80-pin plastic QFP • 80-pin ceramic WQFN	• 80-pin plastic QFP	• 80-pin plastic QFP • 80-pin ceramic WQFN

General Purpose Series

■ μ PD7500X series

Type number		μ PD75004/006/008	μ PD75P008
ROM (bytes)		4096/6016/8064	8064 (PROM)
RAM (∞ 4 bits)		512	
General registers		4-bit ∞ 8 or 8-bit ∞ 4	
Instruction cycle		Selectable from 0.95 μ s/1.91 μ s/15.3 μ s (at main clock 4.19 MHz) and 122 μ s (at subclock 32 kHz)	
Input/ output ports	CMOS inputs	34	8 (also serve as INT, SIO)
	CMOS inputs/outputs		18 (4 can drive LED)
	N-ch inputs/outputs		8 (can drive LED, withstand voltage 10 V, can be pulled up by mask option except PROM version)
Timer/Counters		3 channels • Timer/event counter, • Basic interval timer, • Watch timer	
Serial interface		NEC standard serial bus interface/3-line serial interface	
Interrupts		• Vector interrupts: 6 (external: 3, internal: 3), • Test inputs: 2 (external: 1, internal: 1)	
Instruction set		• Bit data set/reset/test/boolean operation instructions • 4-bit data transfer/operation/increment/decrement/compare instructions • 8-bit data transfer instructions	
Supply voltage		2.7 to 6.0 V	4.5 to 5.5 V
Package		• 42-pin plastic SDIP, • 44-pin plastic QFP	

4-Bit Single Chip Microcomputer
--

General Purpose Series

■ μ PD7502X series

Type number	μ PD75028/036	μ PD75P036	μ PD75048	μ PD75P048
ROM (bytes)	8064/16256	16256 (PROM)	8064	8064 (PROM)
RAM (∞ 4 bits)	512/1024	1024	512	
EEPROM (∞ 4 bits)	None		1024	
General registers	4-bit ∞ 8 or 8-bit ∞ 4			
Instruction cycle	Selectable from 0.95 μ s/1.91 μ s/15.3 μ s (at main clock 4.19 MHz) and 122 μ s (at subclock 32 kHz)			
Input/ output ports	CMOS inputs	12 (also serve as INT, SIO, A/D inputs)	27 can be pulled up by software 4 can be pulled down by software	
	CMOS inputs/outputs	48 24 (4 can drive LED)		
	N-ch inputs/outputs	12 (can drive LED, withstand voltage 10 V, can be pulled up by mask option except PROM version)		
A/D converter	8-bit resolution ∞ 8 channels			
Timer/Counters	4 channels • Timer/event counter • Basic interval timer • Watch timer • Multi-function timer (can be used for integration A/D converter)			
Serial interface	NEC standard serial bus interface/3-line serial interface			
Interrupts	• Vector interrupts: 7 (external: 3, internal: 4) • Test inputs: 2 (external: 1, internal: 1)		• Vector interrupts: 9 (external: 3, internal: 6) • Test inputs: 2 (external: 1, internal: 1)	
Instruction set	• Bit data set/reset/test/boolean operation instructions • 4-bit data transfer/operation/increment/decrement/compare instructions • 8-bit data transfer instructions			
Supply voltage	2.7 to 6.0 V			
Package	• 64-pin plastic SDIP • 64-pin ceramic WQFN (μ PD75P036 only) • 64-pin plastic QFP			

4-Bit Single Chip Microcomputer

General Purpose Series

■ μ PD7506X series

Type number		μ PD75064/066/068	μ PD75P068
ROM (bytes)		4096/6016/8064	8064 (PROM)
RAM (∞ 4 bits)		512	
General registers		4-bit ∞ 8 or 8-bit ∞ 4	
Instruction cycle		Selectable from 0.95 μ s/1.91 μ s/15.3 μ s (at main clock 4.19 MHz) and 122 μ s (at subclock 32 kHz)	
Input/output ports	CMOS inputs	12 (also serve as INT, SIO)	19 can be pulled up by software
	CMOS inputs/outputs	12 (4 can drive LED, also serve as A/D inputs)	
	N-ch inputs/outputs	8 (can drive LED, withstand voltage 10 V, also serve as A/D inputs, can be pulled up by mask option except PROM version)	
A/D converter		8-bit resolution ∞ 8 channels	
Timer/Counters		3 channels • Timer/event counter • Basic interval timer • Watch timer	
Serial interface		NEC standard serial bus interface/3-line serial interface	
Interrupts		• Vector interrupts: 6 (external: 3, internal: 3) • Test inputs: 2 (external: 1, internal: 1)	
Instruction set		• Bit data set/reset/test/boolean operation instructions • 4-bit data transfer/operation/increment/decrement/compare instructions • 8-bit data transfer instructions	
Supply voltage		2.7 to 6.0 V	
Package		• 42-pin plastic SDIP • 44-pin plastic QFP	

Slave Series

■ μ PD754XX series

Type number		μ PD75402A	μ PD75P402
ROM (bytes)		1920	1920 (PROM)
RAM (∞ 4 bits)		64	
General registers		4-bit ∞ 4 or 8-bit ∞ 2	
Instruction cycle		Selectable from 0.95 μ s/1.91 μ s/15.3 μ s (at 4.19 MHz)	
Input/output ports	CMOS inputs	6 (also serve as INT, SIO)	16 can be pulled up by software
	CMOS inputs/outputs	12 (8 can drive LED)	
	N-ch inputs/outputs	4 (can drive LED, withstand voltage 10 V, can be pulled up by mask option except PROM version)	
Timer/Counters		Basic interval timer	
Serial interface		NEC standard serial bus interface/3-line serial interface	
Interrupts		• Vector interrupts: 3 (external: 1, internal: 2) • External test inputs: 1	
Instruction set		• Bit data set/reset/test/boolean operation instructions • 4-bit data transfer/increment/boolean operation/compare instructions • 8-bit data transfer instructions	
Supply voltage		2.7 to 6.0 V	4.5 to 5.5 V
Package		• 28-pin plastic DIP • 28-pin plastic SDIP • 44-pin plastic QFP	

4-Bit Single Chip Microcomputer
--

FIP Driver Series

■ μ PD752XX series

Type number	μ PD75206/208	μ PD75212A/216A/217/218	μ PD75P216A	μ PD75P218	μ PD75268
ROM (bytes)	6016/8064	12160/16256/24448/32640	16256	32640	8064
RAM (∞ 4 bits)	369/497	512/512/768/1024	512	1024	512
General registers	(4-bit ∞ 8) ∞ 4 banks or (8-bit ∞ 4) ∞ 4 banks				4-bit x 8 or 8-bit x 4
Instruction cycle	Selectable from 0.95 μ s/1.91 μ s/15.3 μ s (at main clock 4.19 MHz) and 122 μ s (at subclock 32 kHz)				
Input/ output ports	CMOS inputs	8 (also serve as INT, SIO)			
	CMOS inputs/outputs	32 (8 can drive LED, 4 can be pulled down by mask option except PROM version)			
	P-ch outputs	4 (also serve as segment pins, can be pulled down by mask option except PROM version)			
FIP controller	9 to 12 segments, 9 to 16 digits (can be pulled down by mask option)	9 to 16 segments, 9 to 16 digits (can be pulled down by mask option)	9 to 16 segments, 9 to 16 digits	9 to 16 segments, 9 to 16 digits	9 to 16 segments, 9 to 16 digits (can be pulled down by mask option)
Timer/Counter	4 channels <ul style="list-style-type: none"> • Timer/event counter • Basic interval timer • Watch timer • Timer/pulse generator (can output 14-bit PWM) 				3 channels <ul style="list-style-type: none"> • Timer/event counter • Basic interval timer • Watch timer
Serial interface	3-line serial interface/serial bus interface				
Interrupts	<ul style="list-style-type: none"> • Vector interrupts: 8 (external: 3, internal: 5) • Test inputs: 2 (external: 1, internal: 1) 				<ul style="list-style-type: none"> • Vector interrupts: 6 (external: 3, internal: 3) • Test inputs: 3 (external: 1, internal: 2)
Instruction set	<ul style="list-style-type: none"> • Bit data set/reset/test/boolean operation instructions • 4-bit data transfer/operation/increment/decrement/compare instructions • 8-bit data transfer/operation/increment/decrement/compare instructions (transfer only at μPD75268) 				
Supply voltage	2.7 to 6.0 V		4.5 to 5.5 V	2.7 to 6.0 V	2.7 to 6.0 V
Package	<ul style="list-style-type: none"> • 64-pin plastic SDIP • 64-pin plastic QFP (except μPD75P216A) 				

4-Bit Single Chip Microcomputer

FIP Driver Series

■ μ PD7523X series

Type number		μ PD75236	μ PD75237/238	μ PD75P238
ROM (bytes)		16256	24448/32640	32640 (PROM)
RAM (∞ 4 bits)		768	1024	1024
General registers		(4-bit ∞ 8) ∞ 4 banks or (8-bit ∞ 4) ∞ 4 banks		
Instruction cycle		Selectable from 0.95 μ s/1.91 μ s/3.81 μ s/15.3 μ s (at main clock 4.19 MHz) and 122 μ s (at subclock 32 kHz)	Selectable from 0.67 μ s/1.33 μ s/2.67 μ s/10.7 μ s (at main clock 6 MHz) 122 μ s (at subclock 32 kHz)	
Input/ output ports	CMOS inputs	16 (also serve as INT, SIO, A/D inputs)	19 can be pulled up by software 4 can be pulled down by mask option	Same as left (however, no mask option)
	CMOS inputs/outputs	16		
	N-ch inputs/ outputs	8 (withstand voltage 10 V, can be pulled up by mask option)		
	P-ch outputs	24 (also serve as segment pins, can be pulled down by mask option)		
FIP controller		9 to 24 segments, 9 to 16 digits (can be pulled down by mask option except μ PD75P238)		
A/D converter		8-bit resolution x 8 channels		
Timer/Counters		5 channels • Timer/event counter • Event counter • Basic interval timer • Watch timer • Timer/pulse generator (can output 14-bit PWM)		
Serial interface		2 channels • NEC standard serial bus interface/3-line serial interface • 3-line serial interface		
Interrupts		• Vector interrupts: 8 (external: 3, internal: 5) • Test inputs: 3 (external: 1, internal: 2)		
Instruction set		• Bit data set/reset/test/boolean operation instructions • 4/8-bit data transfer/operation/increment/decrement/compare instructions		
Supply voltage		2.7 to 6.0 V		
Package		• 94-pin plastic QFP		• 94-pin plastic QFP • 94-pin ceramic WQFN

4-Bit Single Chip Microcomputer

LCD Driver Series

■ μ PD7530X series

Type number		μ PD75304/306/308/312/316	μ PD75P316A	μ PD75304B/306B/308B	μ PD75312B/316B	μ PD75P316B
ROM (bytes)		4096/6016/8064/12160/16256	16256 (PROM)	4096/6016/8064	12160/16256	16256 (PROM)
RAM (∞ 4 bits)		512	1024	512	1024	
General registers		4-bit ∞ 8 or 8-bit ∞ 4				
Instruction cycle		Selectable from 0.95 μ s/1.91 μ s/15.3 μ s (at main clock 4.19 MHz) and 122 μ s (at subclock 32 kHz)				
Input/ output ports	CMOS inputs	32 (40 MAX.)	8 (also serve as INT, SIO)	Can be pulled up by software except P00		
	CMOS inputs/outputs		16 (4 can drive LED)			
	N-ch inputs/outputs		8 (can drive LED, withstand voltage 10 V, can be pulled up by mask option except PROM version)			
	CMOS outputs		4/8 (also serve as segment outputs, selection by software)			
LCD controller		<ul style="list-style-type: none"> • Segment outputs: 32 ∞ 4 (MAX.) • Display mode (static, 1/2, 1/3, 1/4 duty) • LCD drive voltage generation step down register (except PROM version) 				
Timer/Counters		3 channels • Timer/event counter <ul style="list-style-type: none"> • Basic interval timer • Watch timer 				
Serial interface		NEC standard serial bus interface/3-line serial interface				
Interrupts		<ul style="list-style-type: none"> • Vector interrupts: 6 (external: 3, internal: 3) • Test inputs: 2 (external: 1, internal: 1) 				
Instruction set		<ul style="list-style-type: none"> • Bit data set/reset/test/boolean operation instructions • 4-bit data transfer/operation/increment/decrement/compare instructions • 8-bit data transfer instructions 				
Supply voltage		2.7 to 6.0 V		2.0 to 6.0 V		2.0 to 6.0 V
Package		<ul style="list-style-type: none"> • 80-pin plastic QFP (0.8 mm pitch) • 80-pin ceramic WQFN (0.8 mm pitch: μPD75P316A only) 		<ul style="list-style-type: none"> • 80-pin plastic QFP (0.5/0.65/0.8 mm pitch) 		<ul style="list-style-type: none"> • 80-pin plastic QFP (0.65/0.8 mm pitch) • 80-pin ceramic WQFN (0.65 mm pitch: μPD75P316B only)

4-Bit Single Chip Microcomputer
--

LCD Driver Series

■ μ PD7532X series

Type number	μ PD75328	μ PD75P328	μ PD75336	μ PD75P336
ROM (bytes)	8064	8064 (PROM)	16256	16256 (PROM)
RAM (∞ 4 bits)	512		768	
General registers	4-bit ∞ 8 or 8-bit ∞ 4		(4-bit ∞ 8) ∞ 4 banks or (8-bit ∞ 4) x 4 banks	
Instruction cycle	Selectable from 0.95 μ s/1.91 μ s/15.3 μ s (at main clock 4.19 MHz) and 122 μ s (at subclock 32 kHz)			
Input/ output ports	CMOS inputs	8 (also serve as INT, SIO)		Can be pulled up by software except P00
	CMOS inputs/outputs	20		
	N-ch inputs/outputs	8 (can drive LED, withstand voltage 10 V, can be pulled up by mask option except PROM version)		
	CMOS outputs	8 (also serve as segment outputs)		
LCD controller	<ul style="list-style-type: none"> • Segment outputs: 20 ∞ 4 (MAX.) • Display mode (static, 1/2, 1/3, 1/4 duty) • LCD drive voltage generation step down resistor (except PROM version) 			
A/D converter	8-bit resolution ∞ 6 channels		8-bit resolution ∞ 8 channels	
Timer/Counters	3 channels • Timer/event counter <ul style="list-style-type: none"> • Basic interval timer • Watch timer 		4 channels • Timer/event counter ∞ 2 <ul style="list-style-type: none"> • Basic interval timer • Watch timer 	
Serial interface	NEC standard serial bus interface/3-line serial interface			
Interrupts	<ul style="list-style-type: none"> • Vector interrupts: 6 (external: 3, internal: 3) • Test inputs: 2 (external: 1, internal: 1) 		<ul style="list-style-type: none"> • Vector interrupts: 7 (external: 3, internal: 4) • Test inputs: 2 (external: 1, internal: 1) 	
Instruction set	<ul style="list-style-type: none"> • Bit data set/reset/test/boolean operation instructions • 4-bit data transfer/operation/increment/decrement/compare instructions • 8-bit data transfer/operation/increment/decrement/compare instructions (transfer only except μPD75336) 			
Supply voltage	2.7 to 6.0 V	4.75 to 5.25 V	2.7 to 6.0 V	
Package	• 80-pin plastic QFP (0.65 mm pitch)		• 80-pin plastic QFP (0.5, 0.65 mm pitch)	

4-Bit Single Chip Microcomputer

μPD7500 Series

■ **μPD7500 series product evolution**

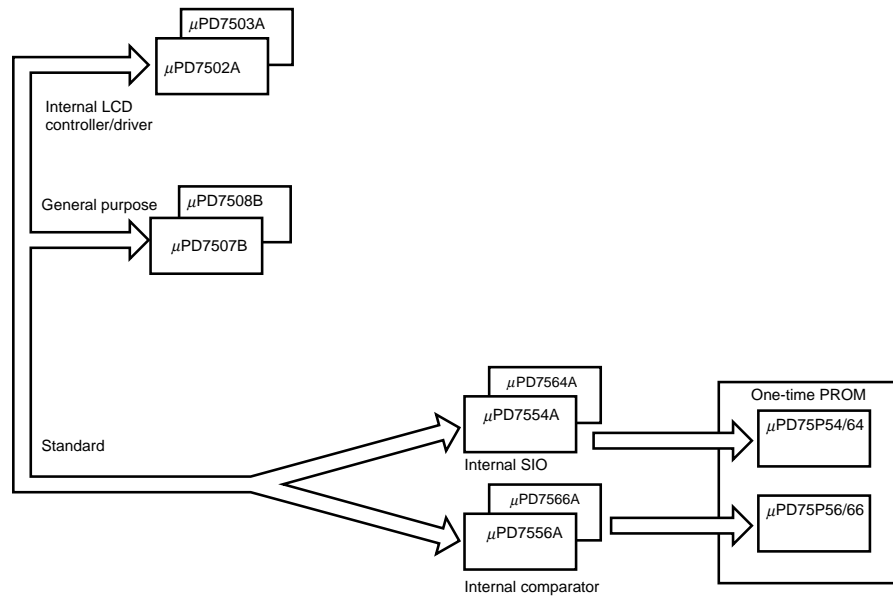

■ **μPD7500 series**

Type number	Features		ROM (∞8)	RAM (∞4)	I/O	Package	Supply voltage
μPD7502A	Internal LCD controller/driver	24 SEG	2K	128	23	• 64-pin QFP	2.5 to 6.0 V
μPD7503A			4K	224			
μPD7507B	General purpose	High speed (2.86 μs)	2K	128	32	• 40-pin SDIP • 44-pin QFP	2.2 to 6.0 V
μPD7508B			4K	224			
μPD7554A	Standard device	Internal serial interface	1K	64	16	• 20-pin SDIP • 20-pin SOP	2.0 to 6.0 V
μPD7564A		Ceramic oscillation			15		2.7 to 6.0 V
μPD7556A	Internal comparator	Internal comparator	1K	64	20	• 24-pin SDIP • 24-pin SOP	2.0 to 6.0 V
μPD7566A		Ceramic oscillation			19		2.7 to 6.0 V
μPD75P54	OTP	For 7554A	1K	64	16	• 20-pin SDIP • 20-pin SOP	4.5 to 6.0 V
μPD75P64		For 7564A			15		
μPD75P56		For 7556A			20	• 24-pin SDIP • 24-pin SOP	
μPD75P66		For 7566A			19		

4-Bit Single Chip Microcomputer

17K Series

17K series product evolution

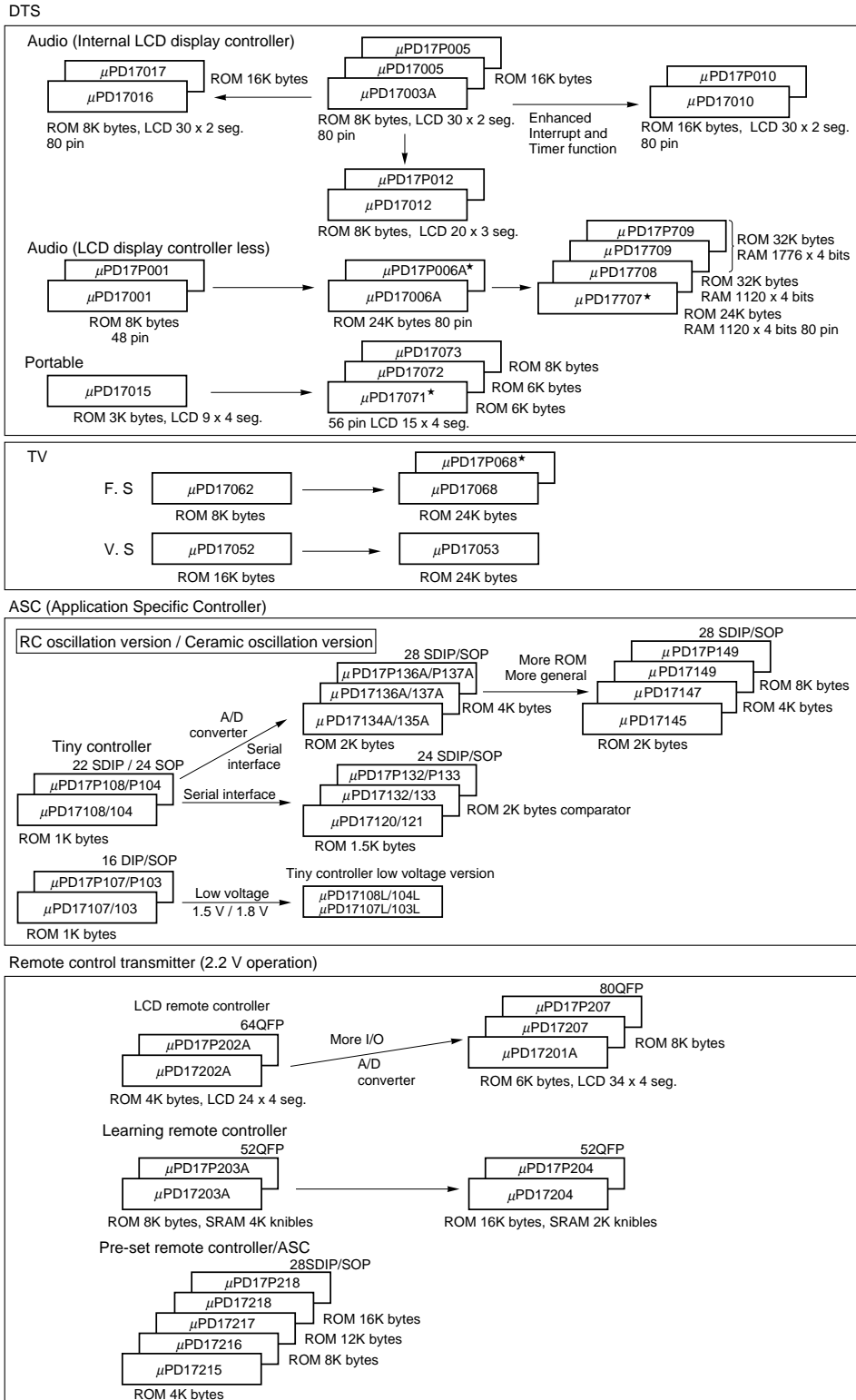

★ : Under development

4-Bit Single Chip Microcomputer

■ μ PD170XX (DTS) (1/3)

	μ PD17001	μ PD17003A	μ PD17005	μ PD17006A	μ PD17010	μ PD17012	μ PD17707*	μ PD17708*	μ PD17709*	
Typical applications	High performance tuner, car radio									
Package	• 48-pin QFP	• 80-pin QFP			• 64-pin QFP		• 80-pin QFP			
Supply voltage	+5 V \pm 10 %									
Supply current (CPU)	500 μ A TYP.									
ROM size	3836 ∞ 16 bits	3836 ∞ 16 bits	7932 ∞ 16 bits	12288 ∞ 16 bits	7932 ∞ 16 bits	4096 ∞ 16 bits	12288 ∞ 16 bits	16384 ∞ 16 bits		
RAM size	224 ∞ 4 bits	320 ∞ 4 bits	432 ∞ 4 bits	896 ∞ 4 bits	432 ∞ 4 bits	316 ∞ 4 bits	1120 ∞ 4 bits		1776 ∞ 4 bits	
Number of instructions	35									
Display	—————	Internal LCD driver Segments : 30 Common : 2		—————	Internal LCD driver Segments : 30 Common : 2		Internal LCD driver Segments : 20 Common : 3			
Input ports	8 lines	8 lines		8 lines	8 lines	8 lines	12 lines			
Output ports	12 lines	9 (+30) lines		13 lines	9 (+30) lines	8 (+20) lines		4 lines		
Input/output ports	12 lines	16 lines		40 lines	16 lines	14 lines		46 lines		
VDP (D/A converter)	4	4		4	4	3		3		
A/D converter	6	6		6	6	2		6		
Crystal oscillator	4.5 MHz									
PLL reference frequency	1, 1.25, 2.5, 3, 5, 6.25, 9, 10, 12.5, 25, 50, 100 kHz						1, 1.25, 2.5, 3.5, 6.25, 9, 10, 12.5, 18, 20, 25, 50, 100 kHz			
Applicable prescaler	Internally provided (130 MHz)	Internally provided (150 MHz)				Internally provided (250 MHz)		Internally provided (130 MHz)		
One-time PROM version	μ PD17P001	μ PD17P005		μ PD17P006A*	μ PD17P010	μ PD17P012	μ PD17P709*			

* : Under development

■ μ PD170XX (DTS) (2/3)

	μ PD17015	μ PD17016	μ PD17017	μ PD17071*	μ PD17072	μ PD17073
Typical applications	Portable tuner radio	High performance tuner, car radio		Portable tuner radio		
Package	• 38-pin shrink SOP	• 80-pin QFP		• 56-pin QFP		
Supply voltage	1.8 ~ 3.6 (PLL is operating)	+5 \pm 10%		1.8 ~ 3.6 (V)		
Supply current (CPU)	30 μ A	500 μ A TYP.		30 μ A		
ROM size	1528 ∞ 16 bits	3836 ∞ 16 bits	7932 ∞ 16 bits	3072 ∞ 16 bits		4096 ∞ 16 bits
RAM size	97 ∞ 4 bits	320 ∞ 4 bits	432 ∞ 4 bits	176 ∞ 4 bits		
Number of instructions	35					
Display	Internal LCD driver Segments : 9 Common : 4	Internal LCD driver Segments : 30 Common : 2		Internal LCD driver Segments : 15 Common : 4		
Input ports	3 lines	8 lines		4 lines		
Output ports	7 lines	9 (+8) lines		9 lines		
Input/output ports	2 lines	16 lines		8 lines		
VDP (D/A converter)	—————	2		—————		
A/D converter	—————	6		—————	2	
Crystal oscillator	75 kHz	4.5 MHz		75 kHz		
PLL reference frequency	1, 3, 5, 12.5 kHz	1, 1.25, 2.5, 3.5, 6.25, 9, 10, 12.5, 25, 50, 100 kHz		1, 3, 5, 6.25, 12.5, 25 kHz		
Applicable prescaler	Internal provided (220 MHz)	Internal provided (150 MHz)		Internal provided (230 MHz)		
One-time PROM version	—————	μ PD17P005		—————		

* : Under development

4-Bit Single Chip Microcomputer

■ μ PD170XX (DTS) (3/3)

	μ PD17062	μ PD17068	μ PD17052	μ PD17053
Typical applications	TV, CATV, LCD TV			
Package	<ul style="list-style-type: none"> • 48-pin shrink DIP • 64-pin QFP 	<ul style="list-style-type: none"> • 100-pin QFP 	<ul style="list-style-type: none"> • 64-pin shrink DIP 	<ul style="list-style-type: none"> • 64-pin shrink DIP
Supply voltage	+5 V \pm 10 %			
Supply current (CPU)	500 μ A TYP.			
ROM size	3968 x 16 bits	12032 x 16 bits	8192 x 16 bits	12288 x 16 bits
RAM size	336 x 4 bits	1007 x 4 bits	448 x 4 bits	672 x 4 bits
Number of instructions	35			
Display	IDC (internally provided) 99 characters max. per frame Display: 14 rows ∞ 19 columns 120 different characters	IDC (internally provided) 192/350 character Display: 17/15 rows ∞ 24 columns 255 different characters	IDC (internally provided) 99 characters max. per frame Display: 14 rows ∞ 19 columns 128 different characters	IDC (internally provided) 99 characters max. per frame Display: 14 rows ∞ 19 columns 256 different characters
Input ports	4 lines	4 lines	4 lines	
Output ports	8 lines	21 lines	20 lines	
Input/output ports	15 lines	19 lines	20 lines	
VDP (D/A converter)	4	9	4	
A/D converter	6	8	8	
Crystal oscillator	8 MHz		8 MHz (ceramic resonator)	
PLL reference frequency	6.25, 12.5, 25 kHz	5, 6.25, 10, 12.5, 25 kHz	Voltage synthesizer (14-bit D/A converter internally provided)	
Applicable prescaler	μ PB595 (1 GHz)		_____	
One-time PROM version	_____	μ PD17P068*	_____	

* : Under development

4-Bit Single Chip Microcomputer

■ μ PD17103 Sub-series (ASC) (1/3)

Item	μ PD17103	μ PD17104	μ PD17103L	μ PD17104L	μ PD17107	μ PD17108	μ PD17107L	μ PD17108L
ROM size	512 ∞ 16 bits							
RAM size	16 ∞ 4 bits							
Input/output ports Parentheses indicate number of N-ch open- drain pins	11 lines (3 lines)	16 lines (4 lines)	11 lines (3 lines)	16 lines (4 lines)	11 lines (3 lines)	16 lines (4 lines)	11 lines (3 lines)	16 lines (4 lines)
System clock	Ceramic oscillation				RC oscillation			
Supply voltage	2.7 to 6.0 V (at 2MHz) 4.5 to 6.0 V (at 8 MHz)		1.8 to 3.6 V (at 2 MHz)		2.7 to 6.0 V (at 250 kHz) 4.5 to 6.0 V (at 1 MHz)		1.5 to 3.6 V (at 200 kHz)	
Package	• 16-pin DIP • 16-pin SOP	• 22-pin shrink DIP • 24-pin SOP	• 16-pin DIP • 16-pin SOP	• 22-pin shrink DIP • 24-pin SOP	• 16-pin DIP • 16-pin SOP	• 22-pin shrink DIP • 24-pin SOP	• 16-pin DIP • 16-pin SOP	• 22-pin shrink DIP • 24-pin SOP
PROM version	μ PD17P103	μ PD17P104	μ PD17P103	μ PD17P104	μ PD17P107	μ PD17P108	μ PD17P107	μ PD17P108

■ μ PD17120 Sub-series/ μ PD17134A Sub-series (ASC) (2/3)

Item	μ PD17120	μ PD17121	μ PD17132	μ PD17133	μ PD17134A	μ PD17135A	μ PD17136A	μ PD17137A
ROM size	768 ∞ 16 bits		1024 ∞ 16 bits		1024 ∞ 16 bits		2048 ∞ 16 bits	
RAM size	64 ∞ 4 bits		111 ∞ 4 bits		112 ∞ 4 bits		112 ∞ 4 bits	
Input/output ports	19 lines (input: 1)				22 lines (input: 2)			
External interrupt	1 line				1 line			
Analog inputs	—		Comparator 4 channels*		A/D converter 4 channels			
Timers	1 channel				3 channels			
Serial interface	1 channel				1 channel			
Power-on reset	Provided (Built-in)				Provided (Built-in)			
System clock	RC oscillation	Ceramic oscillation	RC oscillation	Ceramic oscillation	RC oscillation	Ceramic oscillation	RC oscillation	Ceramic oscillation
Instruction execution time	8 μ s: @2 MHz	2 μ s: @8 MHz	8 μ s: @2 MHz	2 μ s: @8 MHz	8 μ s: @2 MHz	2 μ s: @8 MHz	8 μ s: @2 MHz	2 μ s: @8 MHz
Supply voltage	2.7 to 5.5 V				2.7 to 5.5 V (When using A/D converter 5 V \pm 10 %)			
Package	• 24-pin shrink DIP • 18-pin SOP				• 28-pin shrink DIP • 28-pin SOP			
One-time PROM version	μ PD17P132	μ PD17P133	μ PD17P132	μ PD17P133	μ PD17P136A	μ PD17P137A	μ PD17P136A	μ PD17P137A

*: can be used as low-resolution A/D converter by software

■ μ PD17145 Sub-series (ASC) (3/3)

Item	μ PD17145	μ PD17147	μ PD17149
ROM size	1024 ∞ 16 bits	2048 ∞ 16 bits	4096 ∞ 16 bits
RAM size	110 ∞ 4 bits		
Input/output ports	23 lines (input: 3)		
External interrupt	1 line		
Analog inputs	A/D converter 4 channels		
Timers	3 channels		
Serial interface	1 channel		
Power-on reset	Provided (Mask option)		
System clock	Ceramic oscillation		
Instruction execution time	2 μ s: @8 MHz		
Supply voltage	2.7 to 5.5 V (when using A/D converter 4.0 ~ 5.5 V, V _{REF} = 2.5 ~ V _{DD})		
Package	• 28-pin shrink DIP • 28-pin SOP		
One-time PROM version	μ PD17P149		

4-Bit Single Chip Microcomputer

■ μ PD172XX (remote control transmitter) (1/2)

	μ PD17201A	μ PD17207	μ PD17202A	μ PD17203A	μ PD17204
ROM size	3072 ∞ 16 bits	4096 ∞ 16 bits	2048 ∞ 16 bits	4096 ∞ 16 bits	7936 ∞ 16 bits
RAM size	336 ∞ 4 bits		112 ∞ 4 bits	336 ∞ 4 bits	
Stack level	5 levels		5 levels	5 levels	7 levels
Input/output ports	19 lines		16 lines	28 lines	
External interrupt	1 line				
Timers	2 lines		2 lines	4 lines	
Static RAM	None		None	4K nibbles	2K nibbles
Infrared remote control carrier generator	Internally provided				
Infrared remote control signal receive amplifier	None			Internally provided	
LCD controller/driver	136 segments max.		96 segments max.	None	
8-bit A/D converter	4 channels		None		
Low voltage detection circuit	None				
Subclock (32 kHz)	Internally provided				
Operation voltage range	2.2 to 5.5 V				
Instruction execution time (4 MHz)	4 μ s				
Package	• 80-pin plastic QFP		• 64-pin plastic QFP	• 52-pin plastic QFP	• 52-pin plastic QFP
One-time PROM version	μ PD17P207*		μ PD17P202A	μ PD17P203A	μ PD17P204

* : Under development

■ μ PD172XX (remote control transmitter/ASC) (2/2)

	μ PD17215	μ PD17216	μ PD17217	μ PD17218
ROM size	2048 ∞ 16 bits	4096 ∞ 16 bits	6144 ∞ 16 bits	8192 ∞ 16 bits
RAM size	111 ∞ 4 bits		223 ∞ 4 bits	
Stack level	5 levels			
Input/output ports	20 lines			
External interrupt	1 line			
Timers	2 lines			
Infrared remote control carrier generator	Internally provided			
Low voltage detection circuit	Internally provided ($\overline{\text{WDOUT}}$)			
Operation voltage range	2.2 to 5.5 V (4 μ s) 2.0 to 5.5 V (8 μ s)			
Instruction execution time (4 MHz)	4 μ s (high speed mode)			
Package	• 28-pin plastic SOP • 28-pin shrink DIP			
One-time PROM version	μ PD17P218			

4-Bit Single Chip Microcomputer

■ μ PD1700series (DTS) (1/2)

	μ PD1708A	μ PD1709A	μ PD1713A
Typical applications	Car radio, tuner	TV, CATV	Car radio, tuner
Package	• 52-pin QFP	• 28-pin shrink DIP	• 52-pin QFP
Supply voltage	5 V \pm 10 %		
Supply current (CPU)	400 μ A TYP.	600 μ A TYP.	400 μ A TYP.
ROM	16 bits x 1528 steps	16 bits x 1526 steps	16 bits x 1528 steps
RAM	4 bits x 96 words	4 bits x 64 words	4 bits x 96 words
Number of instructions	77	82	79
Display	LCD (1/2 duty)	LED	LCD (1/2 duty)
Segments	Internal LCD driver provided Segments: 23 Commons: 2	7 (internal LED driver provided) 2	Internal LCD driver provided Segments: 21 Commons: 2
Digits			
Input ports	4 (K ₀ to K ₃)	0	4 (K ₀ to K ₃) + 2
Output ports	8	2	7
I/O ports	4	6 (internal serial I/O provided)	4
VDP (D/A converter)	0	1	0
A/D converter	0	1	0
Crystal oscillator	4.5 MHz		
PLL reference frequency	1, 5, 6.25, 9, 10, 12.5, 25 kHz		
Applicable prescaler	Internally provided (150 MHz)	μ PB595 (1 GHz)	Internally provided (150 MHz)

■ μ PD1700series (DTS) (2/2)

	μ PD1715	μ PD1716	μ PD1720A	μ PD1721	μ PD1723
Typical applications	Portable radio	TV, VCR, car radio, high performance tuner	Car radio (for AM radio)	TV, VCR	High performance tuner, car radio
Package	• 54-pin QFP	• 28-pin shrink DIP	• 52-pin QFP	• 28-pin shrink DIP	• 64-pin QFP
Supply voltage	2.0 V to 3.6 V	5 V \pm 10 %			
Supply current (CPU)	30 μ A TYP.	500 μ A TYP.	400 μ A TYP.	600 μ A TYP.	500 μ A TYP.
ROM	16 bits ∞ 1528 steps	16 bits ∞ 1016 steps	16 bits ∞ 1016 steps	16 bits ∞ 1526 steps	16 bits ∞ 2040 steps
RAM	4 bits ∞ 96 words	4 bits ∞ 64 words	4 bits ∞ 64 words	4 bits ∞ 64 words	4 bits ∞ 256 words
Number of instructions	76	82	78	82	94
Display	LCD (1/3 duty)	–	LCD (1/2 duty)	LED	LCD (1/2 duty)
Segments	Internal LCD driver provided Segments: 16 Commons: 3	–	Internal LCD driver provided Segments: 21 Commons: 2	7	Internal LCD driver provided Segments: 28 Commons: 2
Digits					
Input ports	4 (K ₀ to K ₃)	0	4 (K ₀ to K ₃)	0	4 (K ₀ to K ₃)
Output ports	9	5	7	2	12
I/O ports	4	8	4	6 (internal serial I/O provided)	8 (internal serial I/O provided)
VDP (D/A converter)	1	0	0	1	1
A/D converter	0	1	0	1	1
Crystal oscillator	75 kHz	4.5 MHz			
PLL reference frequency	1, 3, 5, 6.25, 12.5, 25 kHz	1, 5, 6.25, 9, 10, 12.5, 25 kHz			
Applicable prescaler	Internally provided (130 MHz)	Internally provided (150 MHz) μ PB587 (1 GHz)	–	μ PB595 (1 GHz)	Internally provided (150 MHz)

4-Bit Single Chip Microcomputer

■ μ PD6133 series (remote control transmitter/ASC)

Type number	μ PD6133	μ PD63*	μ PD6134	μ PD64*	μ PD6604
Operating voltage range	1.8 to 3.6 V				
Operation clock (f_x)	300 k to 1 MHz	2 M to 8 MHz	300 k to 1 MHz	2 M to 8 MHz	300 k to 1 MHz
	Ceramic oscillator			CR oscillator	
ROM size	512 \times 10 bits		1002 \times 10 bits		
RAM size	32 \times 4 bits				
Modulation carrier frequency	f_x , $f_x/2$, $f_x/8$, $f_x/12$, $f_x/16$, $f_x/24$, High level				
9 bits timer	1 ch				
Number of keys	8 \times 6 = 48				
Low voltage detection circuit	Provided (Mask-option)				
Package	• 20-pin SOP		• 20-pin SOP • 20-pin shrink DIP		• 20-pin shrink SOP • 20-pin SOP
Flash EEPROM version	μ PD61F35*				

*: Under development

8-Bit Single Chip Microcomputer

87AD Series

■ **87AD series product evolution**

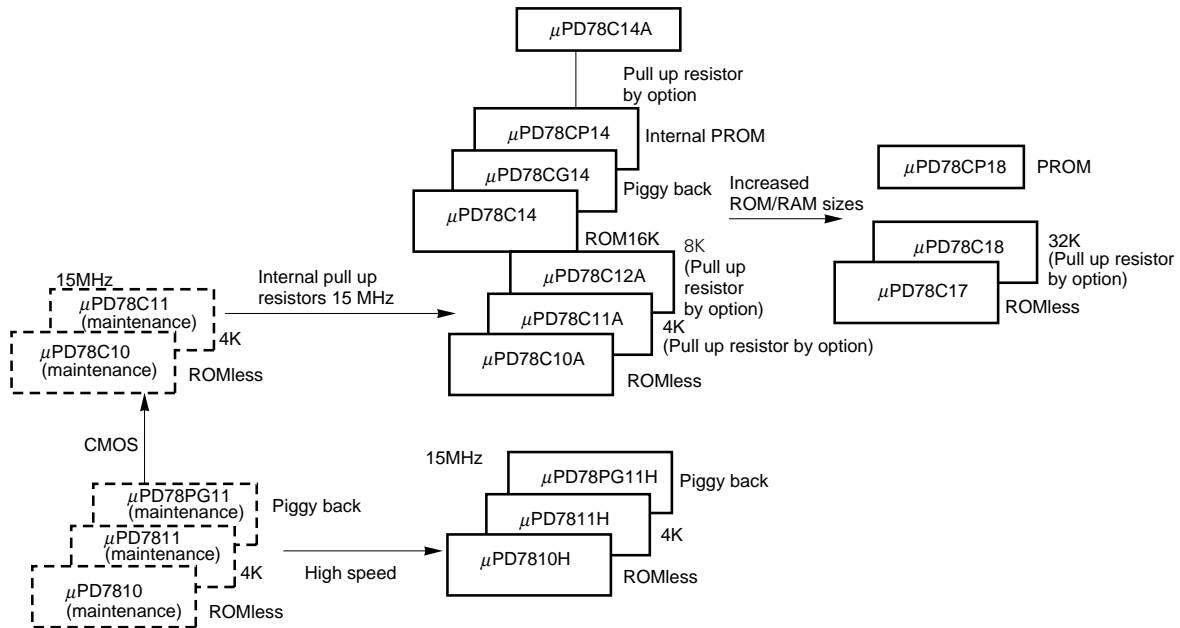

■ **87AD series (1/2)**

Item	μPD7811H/10H	
Number of instructions	158	
Minimum instruction execution cycle	0.8 μs/15 MHz	
Internal memory	ROM size	4096 ∞ 8 bits (μPD7810H is ROMless)
	RAM size	256 ∞ 8 bits
Inter-rupts	External sources	3 (NMI, INT 1, 2)
	Internal sources	8 (INTT 0, 1), (INTE 0, 1), (INTEIN, INTAD), (INTSR, INTST)
Timer/Counters	8-bits ∞ 2, 16-bit ∞ 1	
I/O pins	Input ports	8-bit (AN)
	Input/output ports	8-bit ∞ 5 (PA, PB, PC, PD, PF)
	Serial I/O	1 channel (PC 0/TxD), (PC 1/RxD), (PC 2/SCK)
Features	<ul style="list-style-type: none"> • 8 analog signal input pins. Internal 8-bit high precision A/D converter (absolute accuracy: 0.4 % ±1/2 LSB) • Serial interface can accommodate asynchronous, synchronous, and I/O interface (capable of 9600 bps in asynchronous mode). • Enhanced timer/counters for control applications • Internal zero-cross detection function for time or phase control. Enhanced interrupt function for effective utilization of abundant internal functions. 	
Process	N-MOS	
Package	• 64-pin QUIP/SDIP	
Piggy back or EPROM version	μPD78PG11H	

8-Bit Single Chip Microcomputer

■ 87AD series (2/2)

Item	μ PD78C11A/10A	μ PD78C12A	μ PD78C14	μ PD78C14A	μ PD78C18/17
Number of instructions	159				
Minimum instruction execution cycle	0.8 μ s/15 MHz				
Internal memory	ROM size	4K bytes (μ PD78C10A is ROMless)	8K bytes	16K bytes	32K bytes (μ PD78C17 is ROMless)
	RAM size	256 \times 8-bits			1024 \times 8-bits
Inter-rupts	External sources	3			
	Internal sources	8			
Timer/Counters	8-bits \times 2, 16-bit \times 1				
I/O pins	Input ports	8-bit (AN)			
	Input/output ports	8-bit \times 5 (PA, PB, PC, PD, PF)			
	Serial I/O	1 channel (PC 0/TxD), (PC 1/RxD), (PC 2/SCK)			
Features	<ul style="list-style-type: none"> Full CMOS version of μPD7811H Enhanced standby function (STOP mode) Low power consumption: 1μA at 2.5 V (typ.) Internal pull up resistors can be specified for ports A, B, and C, by mask option for μPD78C11A. 	<ul style="list-style-type: none"> 8K-byte ROM version of μPD78C11A Internal pull up resistors can be specified. 	<ul style="list-style-type: none"> 16K-byte ROM version of μPD78C11 	<ul style="list-style-type: none"> Same functions as μPD78C14 Internal pull up resistors can be specified. Package size: 14 mm \times 14 mm Pin pitch: 0.8 mm For super miniature size system. 	<ul style="list-style-type: none"> Large internal ROM/ RAM ROM: 32K bytes (μPD78C18) RAM: 1024 bytes Internal pull up resistors can be specified (μPD78C18)
Process	CMOS				
Package	<ul style="list-style-type: none"> 64-pin QUIP/SDIP/QFP (14 mm \times 20 mm) 68-pin QFJ 			<ul style="list-style-type: none"> 64-pin QFP (\square 14 mm) 	<ul style="list-style-type: none"> 64-pin QUIP/SDIP/QFP (14 mm \times 20 mm)
Piggy back or EPROM version	μ PD78CG14, μ PD78CP14				μ PD78CP18

8/16-Bit Single Chip Microcomputer

78K Series

■ 78K series product evolution

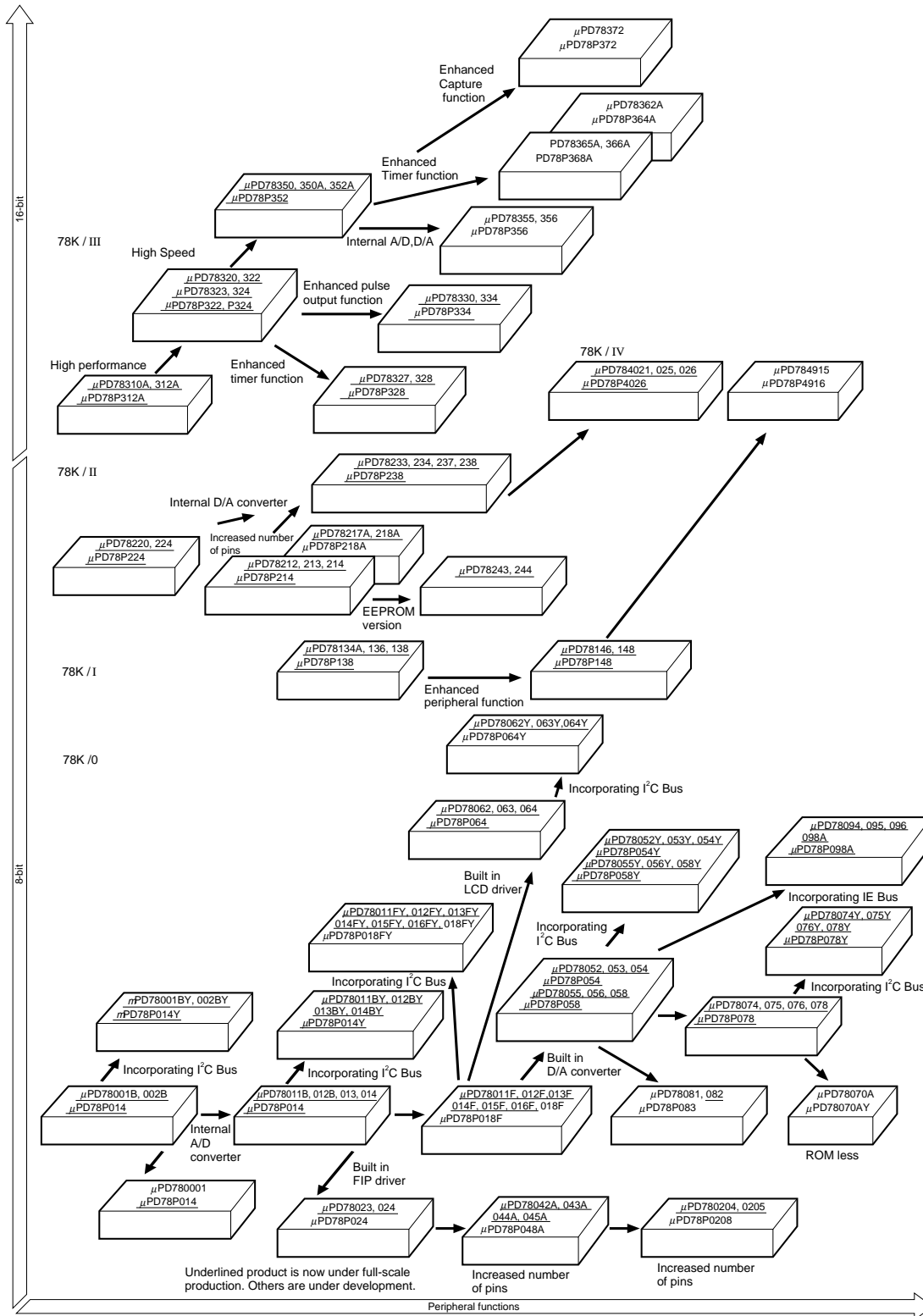

8/16-Bit Single Chip Microcomputer

■ 78K/0 series (General purpose series)

Type number		μ PD780001*	μ PD78001B	μ PD78002B	μ PD78011B	μ PD78012B	μ PD78013	μ PD78014	μ PD78P014	
Number of instruction		63	61		63					
Instruction cycle	Main system clock	0.4 μ s, 0.8 μ s, 1.6 μ s, 3.2 μ s, 6.4 μ s (10 MHz operation)								
	Sub system clock	122 μ s (32.768 kHz operation)								
Memory space extension function		64K bytes								
General register		8-bit ∞ 8 ∞ 4 banks								
Internal memory	ROM size	8K bytes		16K bytes	8K bytes	16K bytes	24K bytes	32K bytes		
	Internal high speed RAM	192 bytes	256 bytes	384 bytes	512 bytes		1024 bytes			
	Buffer RAM size	-		-	32 bytes		32 bytes			
Interrupt	Internal source	7			10					
	External source	4	5		5					
I/O port	CMOS input	4	2		2					
	CMOS input/output	35	47		47					
	N-ch open-drain I/O	-	4		4					
Timer/Counter		8-bit timer ∞ 2 Watchdog timer ∞ 1	8-bit timer ∞ 2 Watch timer ∞ 1 Watchdog timer ∞ 1		16-bit timer ∞ 1 8-bit timer ∞ 2 Watch timer ∞ 1 Watchdog timer ∞ 1					
Serial interface		Clock synchronized ∞ 1 ch			Clock synchronized ∞ 1 ch Clock synchronized with automatic TX/RX function ∞ 1 ch					
A/D converter		8-bit ∞ 8 ch	-		8-bit ∞ 8 ch					
Operation voltage		2.7 to 6.0 V			2.7 to 6.0 V					
Package		<ul style="list-style-type: none"> • 64-pin plastic shrink DIP • 64-pin plastic QFP (□14 mm) 			<ul style="list-style-type: none"> • 64-pin plastic shrink DIP • 64-pin plastic QFP (□14 mm) 			<ul style="list-style-type: none"> • 64-pin plastic shrink DIP • 64-pin plastic QFP (□14 mm) • 64-pin ceramic shrink DIP with window 		

* : Under development

8/16-Bit Single Chip Microcomputer

■ 78K/0 series (General purpose with I²C bus interface series)

Type number		μ PD78001BY	μ PD78002BY	μ PD78011BY	μ PD78012BY	μ PD78013Y	μ PD78014Y	μ PD78P014Y	
Number of instruction		61			63				
Instruction cycle	Main system clock	0.4 μ s, 0.8 μ s, 1.6 μ s, 3.2 μ s, 6.4 μ s (10 MHz operation)							
	Sub system clock	122 μ s (32.768 kHz operation)							
Memory space extension function		64K bytes							
General register		8-bit ∞ 8 ∞ 4 banks							
Internal memory	ROM size	8K bytes	16K bytes	8K bytes	16K bytes	24K bytes	32K bytes		
	Internal high speed RAM	256 bytes	384 bytes	512 bytes			1024 bytes		
	Buffer RAM size	–	–	32 bytes			32 bytes		
Interrupt	Internal source	7			10				
	External source	5			5				
I/O port	CMOS input	2			2				
	CMOS input/output	47			47				
	N-ch open-drain I/O	4			4				
Timer/Counter		8-bit timer ∞ 2 Watch timer ∞ 1 Watchdog timer ∞ 1			16-bit timer ∞ 1 8-bit timer ∞ 2 Watch timer ∞ 1 Watchdog timer ∞ 1				
Serial interface		Clock synchronized ∞ 1 ch			I ² C bus interface ∞ 1 ch Clock synchronized with automatic TX/RX function ∞ 1 ch				
A/D converter		–			8-bit ∞ 8 ch				
Operation voltage		2.7 to 6.0 V			2.7 to 6.0 V				
Package		<ul style="list-style-type: none"> • 64-pin plastic shrink DIP • 64-pin plastic QFP (□14 mm) 		<ul style="list-style-type: none"> • 64-pin plastic shrink DIP • 64-pin plastic QFP (□14 mm) 			<ul style="list-style-type: none"> • 64-pin plastic shrink DIP • 64-pin plastic QFP (□14 mm) • 64-pin ceramic shrink DIP with window 		

8/16-Bit Single Chip Microcomputer

■ 78K/0 series (General purpose series)

Type number		μ PD78011F	μ PD78012F	μ PD78013F	μ PD78014F	μ PD78015F	μ PD78016F	μ PD78018F*	μ PD78P018F*
Number of instruction		63							
Instruction cycle	Main system clock	0.4 μ s, 0.8 μ s, 1.6 μ s, 3.2 μ s, 6.4 μ s (10 MHz operation)							
	Sub system clock	122 μ s (32.768 kHz operation)							
Memory space extension function		64K bytes							
General register		8-bit ∞ 8 ∞ 4 banks							
Internal memory	ROM size	8K bytes	16K bytes	24K bytes	32K bytes	40K bytes	48K bytes	60K bytes	
	Internal high speed RAM	512 bytes		1024 bytes		1536 bytes		2048 bytes	
	Buffer RAM size	32 bytes							
Interrupt	Internal source	10							
	External source	5							
I/O port	CMOS input	2							
	CMOS input/output	47							
	N-ch open-drain I/O	4							
Timer/Counter		16-bit timer ∞ 1 8-bit timer ∞ 2 Watch timer ∞ 1 Watchdog timer ∞ 1							
Serial interface		Clock synchronized ∞ 1 ch Clock synchronized with automatic TX/RX function ∞ 1 ch							
A/D converter		8-bit ∞ 8 ch							
Operation voltage		1.8 to 5.5 V							
Package		<ul style="list-style-type: none"> • 64-pin plastic shrink DIP • 64-pin plastic QFP (□12 mm) • 64-pin plastic QFP (□14 mm) 						<ul style="list-style-type: none"> • 64-pin plastic shrink DIP • 64-pin plastic QFP (□12 mm) • 64-pin plastic QFP (□14 mm) • 64-pin ceramic shrink DIP with window • 64-pin ceramic WQFN with window (□14 mm) 	

*: Under development

8/16-Bit Single Chip Microcomputer

■ 78K/0 series (General purpose series)

Type number		μ PD78011FY	μ PD78012FY	μ PD78013FY	μ PD78014FY	μ PD78015FY	μ PD78016FY	μ PD78018FY*	μ PD78P018FY*
Number of instruction		63							
Instruction cycle	Main system clock	0.4 μ s, 0.8 μ s, 1.6 μ s, 3.2 μ s, 6.4 μ s (10 MHz operation)							
	Sub system clock	122 μ s (32.768 kHz operation)							
Memory space extension function		64K bytes							
General register		8-bit ∞ 8 ∞ 4 banks							
Internal memory	ROM size	8K bytes	16K bytes	24K bytes	32K bytes	40K bytes	48K bytes	60K bytes	
	Internal high speed RAM	512 bytes		1024 bytes		1536 bytes		2048 bytes	
	Buffer RAM size	32 bytes							
Interrupt	Internal source	10							
	External source	5							
I/O port	CMOS input	2							
	CMOS input/output	47							
	N-ch open-drain I/O	4							
Timer/Counter		16-bit timer ∞ 1 8-bit timer ∞ 2 Watch timer ∞ 1 Watchdog timer ∞ 1							
Serial interface		I ² C bus interface ∞ 1 ch Clock synchronized with automatic TX/RX function ∞ 1 ch							
A/D converter		8-bit ∞ 8 ch							
Operation voltage		1.8 to 5.5 V							
Package		<ul style="list-style-type: none"> • 64-pin plastic shrink DIP • 64-pin plastic QFP (□12 mm) • 64-pin plastic QFP (□14 mm) 						<ul style="list-style-type: none"> • 64-pin plastic shrink DIP • 64-pin plastic QFP (□12 mm) • 64-pin plastic QFP (□14 mm) • 64-pin ceramic shrink DIP with window • 64-pin ceramic WQFN with window (□14 mm) 	

★: Under development

8/16-Bit Single Chip Microcomputer

■ 78K/0 series (FIP series)

Type number		μ PD78023	μ PD78024	μ PD78P024*
Number of instruction		63		
Instruction cycle	Main system clock	0.4 μ s, 0.8 μ s, 1.6 μ s, 3.2 μ s, 6.4 μ s (5 MHz operation)		
	Sub system clock	122 μ s (32.768 kHz operation)		
General register		8-bit \times 8 \times 4 banks		
Internal memory	ROM size	24K bytes	32K bytes	
	Internal high speed RAM	512 bytes		
	Display data RAM size	32 bytes		
Interrupt	Internal source	11		
	External source	4		
I/O port	CMOS input	2		
	CMOS input/output	26		
	P-ch open-drain output	18		
	P-ch open-drain I/O	8		
Timer/Counter		16-bit timer \times 1 8-bit timer \times 2 Watch timer \times 1 Watchdog timer \times 1		
Serial interface		Clock synchronized \times 2 ch		
A/D converter		8-bit \times 8 ch		
Operation voltage		2.7 to 6.0 V		
Package		<ul style="list-style-type: none"> • 64-pin plastic QFP (14 mm \times 20 mm) • 64-pin plastic shrink DIP 	<ul style="list-style-type: none"> • 64-pin plastic QFP (14 mm \times 20 mm) • 64-pin plastic shrink DIP • 64-pin ceramic shrink DIP with window 	

* : Under development

8/16-Bit Single Chip Microcomputer

■ 78K/0 series (FIP series)

Type number		μ PD78042A	μ PD78043A	μ PD78044A	μ PD78045A	μ PD78P048A
Number of instruction		63				
Instruction cycle	Main system clock	0.4 μ s, 0.8 μ s, 1.6 μ s, 3.2 μ s, 6.4 μ s (5 MHz operation)				
	Sub system clock	122 μ s (32.768 kHz operation)				
General register		8-bit ∞ 8 ∞ 4 banks				
Internal memory	ROM size	16K bytes	24K bytes	32K bytes	40K bytes	60K bytes
	Internal high speed RAM	512 bytes		1024 bytes		
	Buffer RAM size	64 bytes				
	Display data RAM size	48 bytes				
Interrupt	Internal source	12				
	External source	4				
I/O port	CMOS input	2				
	CMOS input/output	27				
	N-ch open-drain I/O	5				
	P-ch open-drain output	18				
	P-ch open-drain I/O	16				
Timer/Counter		16-bit timer ∞ 1 8-bit timer ∞ 2 Watch timer ∞ 1 Watchdog timer ∞ 1 6-bit Up/Down counter ∞ 1				
FIP controller/driver		Display output: 34 • Segment output: 9-24 • Digit output: 2-16				
Serial interface		Clock synchronized ∞ 1 ch Clock synchronized with automatic TX/RX function ∞ 1 ch				
A/D converter		8-bit ∞ 8 ch				
Operation voltage		2.7 to 6.0 V				
Package		• 80-pin plastic QFP (14 mm ∞ 20 mm)			• 80-pin plastic QFP (14 mm ∞ 20 mm) • 80-pin ceramic WQFN (14 mm ∞ 20 mm)	

8/16-Bit Single Chip Microcomputer

■ 78K/0 series (FIP series)

Type number		μ PD780204	μ PD780205	μ PD78P0208*
Number of instruction		63		
Instruction cycle	Main system clock	0.4 μ s, 0.8 μ s, 1.6 μ s, 3.2 μ s, 6.4 μ s (5 MHz operation)		
	Sub system clock	122 μ s (32.768 kHz operation)		
General register		8-bit ∞ 8 ∞ 4 banks		
Internal memory	ROM size	32K bytes	40K bytes	60K bytes
	Internal high speed RAM	1024 bytes		
	Internal extended RAM	–	–	1024 bytes
	Buffer RAM size	64 bytes		
	Display data RAM size	80 bytes		
Interrupt	Internal source	12		
	External source	4		
I/O port	CMOS input	2		
	CMOS input/output	27		
	N-ch open-drain I/O	5		
	P-ch open-drain output	24		
	P-ch open-drain I/O	16		
Timer/Counter		16-bit timer ∞ 1 8-bit timer ∞ 2 Watch timer ∞ 1 Watchdog timer ∞ 1 6-bit Up/Down counter ∞ 1		
FIP controller/driver		Display output: 53 • Segment output: 9-40 • Digit output: 2-16		
Serial interface		Clock synchronized ∞ 1 ch Clock synchronized with automatic TX/RX function ∞ 1 ch		
A/D converter		8-bit ∞ 8 ch		
Operation voltage		2.7 to 6.0 V		
Package		• 100-pin plastic QFP (14 mm ∞ 20 mm)		• 100-pin plastic QFP (14 mm ∞ 20 mm) • 100-pin ceramic WQFN (14 mm ∞ 20 mm)

* : Under development

8/16-Bit Single Chip Microcomputer

■ 78K/0 series (General purpose series)

Type number		μ PD78052	μ PD78053	μ PD78054	μ PD78P054	μ PD78055	μ PD78056	μ PD78058	μ PD78P058
Number of instruction		63							
Instruction cycle	Main system clock	0.4 μ s, 0.8 μ s, 1.6 μ s, 3.2 μ s, 6.4 μ s 12.8 μ s (5.0 MHz operation)							
	Sub system clock	122 μ s (32.768 kHz operation)							
General register		8-bit ∞ 8 ∞ 4 banks							
Internal memory	ROM size	16K bytes	24K bytes	32K bytes	40K bytes	48K bytes	60K bytes		
	Internal high speed RAM	512 bytes	1024 bytes						
	Buffer RAM size	32 bytes							
	Internal extended RAM							1024 bytes	
Interrupt	Internal source	15							
	External source	8							
I/O port	CMOS input	2							
	CMOS input/output	63							
	N-ch open-drain I/O	4							
Timer/Counter		16-bit timer ∞ 1 8-bit timer ∞ 2 Watch timer ∞ 1 Watchdog timer ∞ 1							
Serial interface		Clock synchronized ∞ 1 ch Clock synchronized with automatic TX/RX function ∞ 1 ch Clock synchronized or UART ∞ 1 ch							
A/D converter		8-bit ∞ 8 ch							
D/A converter		8-bit ∞ 2 ch							
Operation voltage		2.0 to 6.0 V							
Package		<ul style="list-style-type: none"> • 80-pin plastic QFP (□12 mm) • 80-pin plastic QFP (□14 mm) 	<ul style="list-style-type: none"> • 80-pin plastic QFP (□12 mm) • 80-pin plastic QFP (□14 mm) • 80-pin ceramic WQFN (□14 mm) 	<ul style="list-style-type: none"> • 80-pin plastic QFP (□14 mm) 	<ul style="list-style-type: none"> • 80-pin plastic QFP (□14 mm) • 80-pin ceramic WQFN (□14 mm) 				

8/16-Bit Single Chip Microcomputer

■ 78K/0 series (General purpose with I²C bus interface series)

Type number	μ PD78052Y	μ PD78053Y	μ PD78054Y	μ PD78P054Y	μ PD78055Y	μ PD78056Y	μ PD78058Y	μ PD78P058Y
Number of instruction	63							
Instruction cycle	Main system clock	0.4 μ s, 0.8 μ s, 1.6 μ s, 3.2 μ s, 6.4 μ s 12.8 μ s (5.0 MHz operation)						
	Sub system clock	122 μ s (32.768 kHz operation)						
General register	8-bit ∞ 8 ∞ 4 banks							
Internal memory	ROM size	16K bytes	24K bytes	32K bytes	40K bytes	48K bytes	60K bytes	
	Internal high speed RAM	512 bytes	1024 bytes					
	Buffer RAM size	32 bytes						
	Internal extended RAM							1024 bytes
Interrupt	Internal source	15						
	External source	8						
I/O port	CMOS input	2						
	CMOS input/output	63						
	N-ch open-drain I/O	4						
Timer/Counter	16-bit timer ∞ 1 8-bit timer ∞ 2 Watch timer ∞ 1 Watchdog timer ∞ 1							
Serial interface	Clock synchronized with I ² C bus interface function ∞ 1 ch Clock synchronized with automatic TX/RX function ∞ 1 ch Clock synchronized or UART ∞ 1 ch							
A/D converter	8-bit ∞ 8 ch							
D/A converter	8-bit ∞ 2 ch							
Operation voltage	2.0 to 6.0 V							
Package	<ul style="list-style-type: none"> • 80-pin plastic QFP (□12 mm) • 80-pin plastic QFP (□14 mm) 		<ul style="list-style-type: none"> • 80-pin plastic QFP (□12 mm) • 80-pin plastic QFP (□14 mm) • 80-pin ceramic WQFN (□14 mm) 		<ul style="list-style-type: none"> • 80-pin plastic QFP (□14 mm) 		<ul style="list-style-type: none"> • 80-pin plastic QFP (□14 mm) • 80-pin ceramic WQFN (□14 mm) 	

8/16-Bit Single Chip Microcomputer

■ 78K/0 series (LCD series)

Type number		μ PD78062	μ PD78063	μ PD78064	μ PD78P064
Number of instruction		63			
Instruction cycle	Main system clock	0.4 μ s, 0.8 μ s, 1.6 μ s, 3.2 μ s, 6.4 μ s, 12.8 μ s (5.0 MHz operation)			
	Sub system clock	122 μ s (32.768 kHz operation)			
General register		8-bit ∞ 8 ∞ 4 banks			
Internal memory	ROM size	16K bytes	24K bytes	32K bytes	
	Internal high speed RAM	512 bytes	1024 bytes		
	Display data RAM size	40 ∞ 4-bit			
Interrupt	Internal source	14			
	External source	7			
I/O port	CMOS input	2			
	CMOS input/output	55			
Timer/Counter		16-bit timer/event counter ∞ 1 8-bit timer/event counter ∞ 2 Watch timer ∞ 1 Watchdog timer ∞ 1			
Serial interface		Clock synchronized ∞ 1 ch Clock synchronized or UART ∞ 1 ch			
A/D converter		8-bit ∞ 8 ch			
LCD controller/driver		<ul style="list-style-type: none"> • Segment output : 40 (max) • Common output : 4 (max) • Display mode : 1/2, 1/3 duty 			
Operation voltage		2.0 to 6.0 V			
Package		<ul style="list-style-type: none"> • 100-pin plastic QFP (\square14 mm, 0.5 mm pitch) • 100-pin plastic QFP (14 mm ∞ 20 mm, 0.65 mm pitch) 		<ul style="list-style-type: none"> • 100-pin plastic QFP (\square14 mm) • 100-pin plastic QFP (14 mm ∞ 20) • 100-pin ceramic WQFN (14 mm ∞ 20 mm) 	

8/16-Bit Single Chip Microcomputer

■ 78K/0 series (LCD series)

Type number		μ PD78062Y	μ PD78063Y	μ PD78064Y	μ PD78P064Y [★]
Number of instruction		63			
Instruction cycle	Main system clock	0.4 μ s, 0.8 μ s, 1.6 μ s, 3.2 μ s, 6.4 μ s, 12.8 μ s (5.0 MHz operation)			
	Sub system clock	122 μ s (32.768 kHz operation)			
General register		8-bit ∞ 8 ∞ 4 banks			
Internal memory	ROM size	16K bytes	24K bytes	32K bytes	
	Internal high speed RAM	512 bytes	1024 bytes		
	Display data RAM size	40 ∞ 4-bit			
Interrupt	Internal source	14			
	External source	7			
I/O port	CMOS input	2			
	CMOS input/output	55			
Timer/Counter		16-bit timer/event counter ∞ 1 8-bit timer/event counter ∞ 2 Watch timer ∞ 1 Watchdog timer ∞ 1			
Serial interface		Clock synchronized with I ² C bus interface function ∞ 1 ch Clock synchronized or UART ∞ 1 ch			
A/D converter		8-bit ∞ 8 ch			
LCD controller/driver		<ul style="list-style-type: none"> • Segment output : 40 (max) • Common output : 4 (max) • Display mode : 1/2, 1/3 duty 			
Operation voltage		2.0 to 6.0 V			
Package		<ul style="list-style-type: none"> • 100-pin plastic QFP (□14 mm, 0.5 mm pitch) • 100-pin plastic QFP (14 mm ∞ 20 mm, 0.65 mm pitch) 		<ul style="list-style-type: none"> • 100-pin plastic QFP (□14 mm) • 100-pin plastic QFP (14 mm ∞ 20) • 100-pin ceramic WQFN (14 mm ∞ 20 mm) 	

★: Under development

8/16-Bit Single Chip Microcomputer

■ 78K/0 series (General purpose series)

Type number		μ PD78074	μ PD78075	μ PD78076	μ PD78078	μ PD78P078	
Number of instruction		63					
Instruction cycle	Main system clock	0.4 μ s, 0.8 μ s, 1.6 μ s, 3.2 μ s, 6.4 μ s, 12.8 μ s (5.0 MHz operation)					
	Sub system clock	122 μ s (32.768 kHz operation)					
Memory space extension function		64K bytes					
General register		8-bit ∞ 8 ∞ 4 banks					
Internal memory	ROM size	32K bytes	40K bytes	48K bytes	60K bytes	60K bytes	
	Internal high speed RAM	1024 bytes					
	Internal extended RAM	_____			1024 bytes		
	Buffer RAM size	32 bytes					
Interrupt	Internal source	17					
	External source	8					
I/O port	CMOS input	2					
	CMOS input/output	78					
	N-ch open-drain I/O	8					
Timer/Counter		16-bit timer ∞ 1 8-bit timer ∞ 4 Watch timer ∞ 1 Watchdog timer ∞ 1					
Serial interface		Clock synchronized ∞ 1 ch Clock synchronized with automatic TX/RX function ∞ 1 ch Clock synchronized or UART ∞ 1 ch					
A/D converter		8-bit ∞ 8 ch					
D/A converter		8-bit ∞ 2 ch					
Operation voltage		1.8 to 5.5 V					
Package		<ul style="list-style-type: none"> • 100-pin plastic QFP (□14 mm) • 100-pin plastic QFP (14 mm ∞ 20 mm) 				<ul style="list-style-type: none"> • 100-pin plastic QFP (□14 mm) • 100-pin plastic QFP (14 mm ∞ 20 mm) • 100-pin ceramic WQFN (14 mm ∞ 20 mm) 	

8/16-Bit Single Chip Microcomputer

■ 78K/0 series (General purpose series)

Type number		μ PD78074Y	μ PD78075Y	μ PD78076Y	μ PD78078Y	μ PD78P078Y
Number of instruction		63				
Instruction cycle	Main system clock	0.4 μ s, 0.8 μ s, 1.6 μ s, 3.2 μ s, 6.4 μ s, 12.8 μ s (5.0 MHz operation)				
	Sub system clock	122 μ s (32.768 kHz operation)				
Memory space extension function		64K bytes				
General register		8-bit ∞ 8 ∞ 4 banks				
Internal memory	ROM size	32K bytes	40K bytes	48K bytes	60K bytes	60K bytes
	Internal high speed RAM	1024 bytes				
	Internal extended RAM	—————			1024 bytes	
	Buffer RAM size	32 bytes				
Inter-rupt	Internal source	17				
	External source	8				
I/O port	CMOS input	2				
	CMOS input/output	78				
	N-ch open-drain I/O	8				
Timer/Counter		16-bit timer ∞ 1 8-bit timer ∞ 4 Watch timer ∞ 1 Watchdog timer ∞ 1				
Serial interface		Clock synchronized with I ² C bus interface function ∞ 1 ch Clock synchronized with automatic TX/RX function ∞ 1 ch Clock synchronized or UART ∞ 1 ch				
A/D converter		8-bit ∞ 8 ch				
D/A converter		8-bit ∞ 2 ch				
Operation voltage		1.8 to 5.5 V				
Package		<ul style="list-style-type: none"> • 100-pin plastic QFP (□14 mm) • 100-pin plastic QFP (14 mm ∞ 20 mm) 			<ul style="list-style-type: none"> • 100-pin plastic QFP (□14 mm) • 100-pin plastic QFP (14 mm ∞ 20 mm) • 100-pin ceramic WQFN (14 mm ∞ 20 mm) 	

8/16-Bit Single Chip Microcomputer

■ 78K/0 series (General purpose series)

Type number		μ PD78070A	μ PD78070AY
Number of instruction		63	
Instruction cycle	Main system clock	0.4 μ s, 0.8 μ s, 1.6 μ s, 3.2 μ s, 6.4 μ s, 12.8 μ s (5.0 MHz operation)	
	Sub system clock	122 μ s (32.768 kHz operation)	
Memory space extension function		64K bytes	
General register		8-bit \times 8 \times 4 banks	
Internal memory	Internal high speed RAM	1024 bytes	
	Buffer RAM size	32 bytes	
Interrupt	Internal source	17	
	External source	8	
I/O port	CMOS input	2	
	CMOS input/output	78	
	N-ch open-drain I/O	8	
Timer/Counter		16-bit timer ∞ 1 8-bit timer ∞ 4 Watch timer ∞ 1 Watchdog timer ∞ 1	
Serial interface		Clock synchronized ∞ 1 ch Clock synchronized with automatic TX/RX function ∞ 1 ch Clock synchronized or UART ∞ 1 ch	Clock synchronized with I ² C bus interface function ∞ 1 ch Clock synchronized with automatic TX/RX function ∞ 1 ch Clock synchronized or UART ∞ 1 ch
A/D converter		8-bit \times 8 ch	
D/A converter		8-bit \times 2 ch	
Operation voltage		1.8 to 5.5 V	
Package		<ul style="list-style-type: none"> • 100-pin plastic QFP (□14 mm) • 100-pin plastic QFP (14 mm \times 20 mm) 	

8/16-Bit Single Chip Microcomputer

■ 78K/0 series (General purpose series)

Type number		μ PD78081 [★]	μ PD78082	μ PD78P083 [★]
Number of instruction		63		
Instruction cycle	Main system clock	0.4 μ s, 0.8 μ s, 1.6 μ s, 3.2 μ s, 6.4 μ s, 12.8 μ s (5.0 MHz operation)		
	Memory space extension function	64K bytes		
General register		8-bit ∞ 8 ∞ 4 banks		
Internal memory	ROM size	8K bytes	16K bytes	24K bytes
	Internal high speed RAM	256 bytes	384 bytes	512 bytes
Inter-rupt	Internal source	8		
	External source	3		
I/O port	CMOS input	1		
	CMOS input/output	32		
Timer/Counter		8-bit timer ∞ 2 Watch timer ∞ 1		
Serial interface		Clock synchronized or UART ∞ 1 ch		
A/D converter		8 bit ∞ 8 ch		
Operation voltage		1.8 to 5.5 V		
Package		<ul style="list-style-type: none"> • 42-pin plastic shrink DIP • 44-pin plastic QFP (10 mm ∞ 10 mm) 	<ul style="list-style-type: none"> • 42-pin plastic shrink DIP • 44-pin plastic QFP (10 mm ∞ 10 mm) • 42-pin ceramic shrink DIP with window 	

★: Under development

8/16-Bit Single Chip Microcomputer

■ 78K/0 series (IEBus controller series)

Type number		μ PD78094	μ PD78095	μ PD78096	μ PD78098A	μ PD78P098A
Number of instruction		63				
Instruction cycle	Main system clock	0.5 μ s, 1.0 μ s, 2.0 μ s, 4.0 μ s, 8.0 μ s 16.0 μ s (6.0 MHz operation)				
	Sub system clock	122 μ s (32.768 kHz operation)				
General register		8-bit \times 8 \times 4 banks				
Internal memory	ROM size	32K bytes	40K bytes	48K bytes	60K bytes	
	Internal high speed RAM	1024 bytes			3072 bytes	
	Buffer RAM size	32 bytes				
Interrupt	Internal source	16				
	External source	8				
I/O port	CMOS input	2				
	CMOS input/output	63				
	N-ch open-drain I/O	4				
Timer/Counter		16-bit timer ∞ 1 8-bit timer ∞ 2 Watch timer ∞ 1 Watchdog timer ∞ 1				
Serial interface		Clock synchronized ∞ 1 ch Clock synchronized with automatic TX/RX function ∞ 1 ch Clock synchronized or UART ∞ 1 ch				
IE bus controller		TX/RX speed: 26k bps (max.)				
A/D converter		8-bit ∞ 8 ch				
D/A converter		8-bit ∞ 2 ch				
Operation voltage		2.7 to 6.0 V				
Package		<ul style="list-style-type: none"> • 80-pin plastic QFP (□14 mm) 			<ul style="list-style-type: none"> • 80-pin plastic QFP (□14 mm) • 80-pin ceramic WQFN (□14 mm) 	

8/16-Bit Single Chip Microcomputer

■ 78K/I series

Type number		μ PD78134	μ PD78134A	μ PD78136	μ PD78138	μ PD78P138	μ PD78146	μ PD78148	μ PD78P148	
Number of instruction		63	64							
Minimum instruction execution cycle		333 ns/12 MHz								
Data memory space extension function		64K bytes					—			
Internal memory	ROM size	16K bytes	24K bytes	32K bytes	32K bytes (PROM)	24K bytes	32K bytes	32K bytes (PROM)		
	RAM size	384 bytes	640 bytes			688 bytes*	816 bytes*			
Inter-rupt	External sources	5					5			
	Internal sources	12					20			
I/O pins	Input ports	10					24			
	Output ports	12					12			
	Input/output ports	36					40			
Analog input		8-bit A/D converter 8 channels					8-bit A/D converter 15 channels			
OP-amp		—					2 channels			
Timer/Counter		16-bit timer ∞ 3 7-bit timer ∞ 1 18-bit free-running-counter ∞ 1					16-bit timer ∞ 3 8-bit timer ∞ 1 22-bit free-running-counter ∞ 1 8-bit up-down-counter ∞ 1			
PWM output		12-bit PWM ∞ 2 (carrier freq. 23.4 KHz)	12-bit PWM ∞ 2 (carrier freq. 23.4 KHz/46.9 KHz)				12-bit PWM ∞ 2 (carrier freq. 23.4 KHz/46.9 KHz) 8-bit PWM ∞ 3 (carrier freq. 5.9 KHz) 14-bit PWM ∞ 1 (carrier freq. 5.9 KHz)			
Multiplier		—					Hardware multiplier is included			
Serial interface		Clock synchronized (can accommodate SBI) 1 channel					Clock synchronized (can accommodate SBI) 1 channel Clock synchronized (automatic data transmit function) 1 channel			
Features		<ul style="list-style-type: none"> System-control and servo control for VCR Multi-function timer set for software servo control application such as VCR 					<ul style="list-style-type: none"> System-control and servo control for VCR Multi-function timer set for software-servo control application such as VCR High-speed multiply with hardware multiplier Low-voltage and low-current count operation with Hardware clock function 			
Package		• 80-pin QFP			• 80-pin QFP • 80-pin WQFN		• 100-pin QFP		• 100-pin QFP • 100-pin WQFN	

*: contained automatic data transmit buffer 48 byte

8/16-Bit Single Chip Microcomputer

■ 78K/II series (1/2)

Type number	μ PD78212	μ PD78213	μ PD78214	μ PD78P214	μ PD78217A	μ PD78218A	μ PD78P218A	μ PD78243	μ PD78244	
Number of instructions	65									
Minimum instruction execution cycle	333 ns/ 12 MHz	500 ns/ 12 MHz	333 ns/12 MHz		500 ns/ 12 MHz	333 ns/12 MHz		500 ns/ 12 MHz	333 ns/ 12 MHz	
Data memory space extension function	1M bytes									
Internal memory	ROM size	8K bytes	–	16K bytes	16K bytes (PROM)	–	32K bytes	32K bytes (PROM)	–	16K bytes
	RAM size	384 bytes	512 bytes			1024 bytes			512 bytes	
	EEPROM size	–							512 bytes	
Inter-rupts	External sources	7								
	Internal sources	12						14		
I/O pins	Inputs	14 (of these, 6 can be pulled up by software)								
	Outputs	12 (of these, 8 can directly drive transistor.)								
	Input/output ports	28 (can be pulled up by software)	10 (can be pulled up by software)	28 (can be pulled up by software). Of these, 16 can directly drive LED.		10 (can be pulled up by software)	28 (can be pulled up by software). Of these, 16 can directly drive LED.		10 (can be pulled up by software)	28 (can be pulled up by software)
Analog inputs	8-bit A/D converter: 8 channels									
Timer/Counter	16-bit timer/counter x 1 8-bit timer/counter x 3									
Serial interface	UART (internal dedicated baud rate generator) ááá 1 channel Clock synchronized (can accommodate SBI) ááááá 1 channel									
Features	• Real-time output port for stepping motor control				• Internal memory extended from μ PD78214			• First EEPROM version in 78K series		
Package	• 64-pin SDIP • 64-pin QUIP (except μ PD78212) • 68-pin QFJ (except μ PD78212) • 64-pin QFP • 74-pin QFP			Same as left • 64-pin SDIP with window	• 64-pin SDIP • 64-pin QFP		Same as left • 64-pin SDIP with window	• 64-pin SDIP • 64-pin QFP		

8/16-Bit Single Chip Microcomputer

■ 78K/II series (2/2)

Type number		μ PD78220	μ PD78224	μ PD78P224	μ PD78233	μ PD78234	μ PD78237	μ PD78238	μ PD78P238
Number of instructions		65							
Minimum instruction execution cycle		500 ns/ 12 MHz	333 ns/12 MHz		500 ns/ 12 MHz	333 ns/ 12 MHz	500 ns/ 12 MHz	333 ns/12 MHz	
Data memory space extension function		1M bytes							
Internal memory	ROM size	–	16K bytes	16K bytes (PROM)	–	16K bytes	–	32K bytes	32K bytes (PROM)
	RAM size	640 bytes			640 bytes		1024 bytes		
Inter-rupts	External sources	8			7				
	Internal sources	9			12				
I/O pins	Inputs	8			16				
	Outputs	12	20		12				
	Input/output ports	25 (of these, 8 can directly drive LED)	35 (of these, 8 can directly drive LED)		18 (can be pulled up by software. 8 can directly drive LED)	36 (can be pulled up by software. 24 can directly drive LED)	18 (can be pulled up by software. 8 can directly drive LED)	36 (can be pulled up by software. 24 can directly drive LED)	
Analog inputs		Variable threshold voltage input port (16 steps): 8			8-bit A/D converter 8 channels				
Analog outputs		—			8-bit D/A converter: 2 outputs				
Timer/Counter		16-bit timer/counter ∞ 1 8-bit timer/counter ∞ 2			16-bit timer/counter ∞ 1 8-bit timer/counter ∞ 3				
Serial interface		UART (internal dedicated baud rate generator) ááá 1 channel Clock synchronized (can accommodate SBI) ááááá 1 channel							
Features		• Real-time output port for stepping motor control			• Real-time output port for stepping motor control • Two 12-bit PWM outputs				
Package		• 94-pin QFP • 84-pin QFJ			• 84-pin QFJ • 80-pin QFP • 94-pin QFP				Same as left • 94-pin WQFN

8/16-Bit Single Chip Microcomputer

■ 78K/III series (1/6)

Type number	μ PD78310A	μ PD78312A	μ PD78P312A	μ PD78320	μ PD78322	μ PD78P322	μ PD78323	μ PD78324	μ PD78P324	
Number of instructions	96			111						
Minimum instruction execution cycle	500 ns/12 MHz			250 ns/16 MHz						
Internal memory	ROM size	–	8K bytes	8K bytes (PROM)	–	16K bytes	16K bytes (PROM)	–	32K bytes	32K bytes (PROM)
	RAM size	256 bytes			640 bytes			1024 bytes		
Inter-rupts	External sources	4			8					
	Internal sources	14			13					
I/O pins	Inputs	8			16					
	Outputs	–			–					
	Input/output ports	24	40		21	39		21	39	
Analog inputs	8-bit A/D converter 4 channels			10-bit A/D converter 8 channels						
Timer/Counter	16-bit up/down counter ∞ 2 16-bit interval timer ∞ 2			18/16-bit free running timer ∞ 1 16-bit timer/event counter ∞ 1						
Serial interface	UART/clock synchronized 1 channel			UART 1 channel Clock synchronized (can accommodate SBI) 1 channel						
Features	<ul style="list-style-type: none"> Compared to μPD78310/μPD78312 and μPD78P312, 16-bit data transfer instructions and 4-multiplied count mode added. Suitable for servo control 			<ul style="list-style-type: none"> Real-time pulse unit which functions as a high performance pulse generator. 						
Package	<ul style="list-style-type: none"> 64-pin SDIP 68-pin QFJ 64-pin QUIP 64-pin QFP 		Same as left <ul style="list-style-type: none"> 64-pin SDIP with window 64-pin QUIP with window 	<ul style="list-style-type: none"> 68-pin QFJ 74-pin QFP 80-pin QFP 	Same as left <ul style="list-style-type: none"> 68-pin WQFN 74-pin WQFN 80-pin WQFN 		<ul style="list-style-type: none"> 68-pin QFJ 74-pin QFP 	Same as left <ul style="list-style-type: none"> 68-pin WQFN 74-pin WQFN 		

8/16-Bit Single Chip Microcomputer

■ 78K/III series (3/6)

Type number	μPD78350	μPD78350A	μPD78352A	μPD78P352	μPD78355	μPD78356	μPD78P356
Number of instructions	113				115		
Minimum instruction execution cycle	160 ns/25 MHz	125 ns/32 MHz			125 ns/32 MHz		
Internal memory	ROM size	–	32K	–	–	48K bytes	–
	PROM size	–		32K	–	–	48K bytes
	RAM size	640 bytes			2K bytes		
Inter-rupts	External sources	5			5		
	Internal sources	4			25		
I/O pins	Inputs	6			8 (8 can also serve as analog input pins)		
	Outputs	–			–		
	Input/output ports	24	44		49	68	
PWM unit	8-bit PWM output 2channels				12-bit PWM output 2 channels		
Analog inputs	–				10-bit A/D converter 8 channels		
					High speed conversion time 2 μs		
Analot outputs	–				8-bit D/A converter 2 channels		
Timer/Counter	16-bit timer ∞ 3				16-bit timer ∞ 2 16-bit counter ∞ 3 10-bit timer ∞ 1		
Serial interface	–				UART áááááááááááááááááá 1 channel Clock synchronized (can accommodate SBI) áááááááááááááááááá 1 channel Clock synchronized (with pin switching function) áááááááááááááááááá 1 channel		
Features	<ul style="list-style-type: none"> Sum of products operation instructions Suitable as ASIC control 				<ul style="list-style-type: none"> Fine pitch package (0.5 mm pitch) Low voltage operation (2.7 to 5.5 V) High performance internal A/D converter and D/A converter suitable for analog data 		
Package	• 64-pin QFP (t = 2.7 mm)	• 64-pin QFP (t = 1.5 mm)	• 64-pin WQFN		• 100-pin plastic QFP • 120-pin plastic QFP	• 120-pin ceramic WQFN	

8/16-Bit Single Chip Microcomputer

■ 78K/IV series (2/2)

Type number		μ PD784915 [★]	μ PD78P4916 [★]
Number of instructions		113	
Minimum instruction execution cycle		250 ns/16 MHz	
Internal memory	ROM size	48K bytes	62K bytes (PROM)
	RAM size	1280 bytes	2048 bytes
Inter-rupts	External sources	9	
	Internal sources	20	
I/O pins	Inputs	8	
	Outputs	0	
	Input/output ports	46	
A/D converter		8-bit resolution ∞ 12 channels	
Analog circuit for VCR		CTL amplifier, RECCTL driver CFG amplifier DFG amplifier, DPG comparater, DPG separation circuit Reel-FG comparater (2 channels) Csync comparater	
Timer/Counter		22-bit FRC counter ∞ 1 16-bit timer ∞ 6 8-bit counter ∞ 2 5-bit UDC counter ∞ 1	
PWM output		16-bit PWM ∞ 3 (carrier freq.: 62.5 kHz) 8-bit PWM ∞ 3 (carrier freq.: 62.5 kHz)	
Serial interface		Clock synchronized ∞ 2 channels	
Features		<ul style="list-style-type: none"> • System-control and servo-control and timer-control for VCR • Super-timer-unit and Analog circuit for software servo control application such as VCR • CPU operation by subsystem clock (Low power operation) 	
Package		<ul style="list-style-type: none"> • 100-pin QFP (14 ∞ 20 mm) 	

★: Under development

V Series™

■ 16-Bit V series product evolution

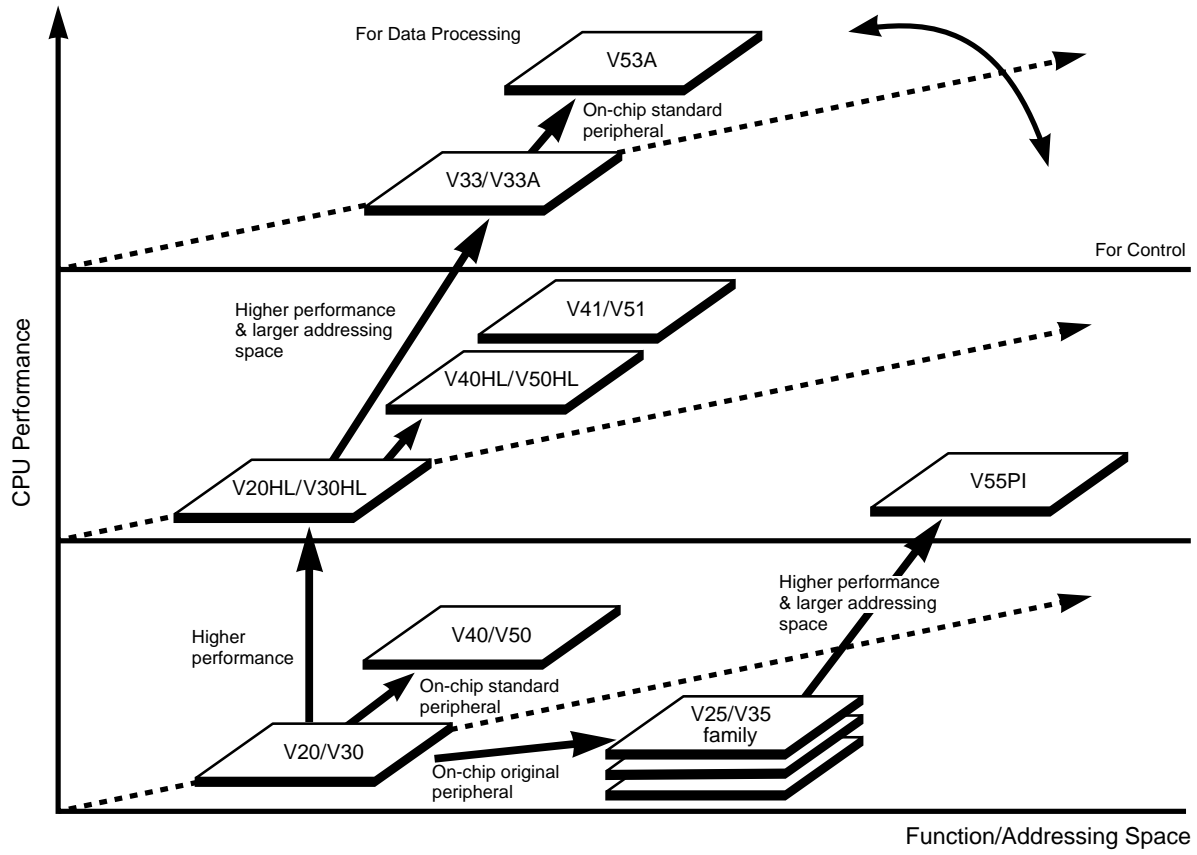

V Series

■ 16-Bit (1/2)

Type number	Alias	Features	Internal bus	External bus	Real memory space	Operating frequency	Package
μ PD70108	V20™	<u>CMOS process</u> High speed, low power consumption Upward software and pin compatible, including interfacing with peripheral controller <u>Measures taken to increase speed</u> <ul style="list-style-type: none"> • Dual data bus system 	16 bits	8 bits	1M bytes	5/8/10 MHz	<ul style="list-style-type: none"> • 40-pin DIP • 44-pin QFJ • 52-pin QFP
μ PD70116	V30™	<ul style="list-style-type: none"> • Effective address generation circuit • Multiplication/division by programmable shifter • High speed processing by dedicated register <u>Two operating modes</u> <ul style="list-style-type: none"> • 8080 emulation mode added <u>Standby function</u>	16 bits	16 bits			
μ PD70108H	V20HL™	<u>V20/V30 compatible, high speed low voltage operation</u> <ul style="list-style-type: none"> • Capable of operating at 16 MHz (at 5 V) • Capable of operating at 3 V (at 8 MHz) • Clock can be stopped 	16 bits	8 bits	1M bytes	10/12.5/16 MHz	<ul style="list-style-type: none"> • 40-pin DIP • 44-pin QFJ • 52-pin QFP • 52-pin TQFP
μ PD70116H	V30HL™		16 bits	16 bits			
μ PD70136A	V33A™	Performance is approximately 4 times higher than V30 16M-byte address extension mode Internal bus sizing function 1 bus cycle = 2 clocks Internal floating point processor (μ PD72291) interface function	16 bits	8/16 bits (Selectable)	16M bytes	10/12.5/16 MHz	<ul style="list-style-type: none"> • 68-pin PGA • 68-pin QFJ
μ PD70136	V33™						<ul style="list-style-type: none"> • 68-pin PGA • 68-pin QFJ • 74-pin QFP
μ PD70208	V40™	<u>V20/V30 + peripheral controllers</u> <u>V20/V30 CPU plus the following peripheral functions:</u> <ul style="list-style-type: none"> • 4-ch DMA controller • 3-ch 16-bit timer/counter • Interrupt controller • Clock generator • DRAM refresh controller • Programmable wait generator (Internal peripheral controllers are subset functions of μ PD7105X series)	16 bits	8 bits	1M bytes	8/10 MHz	<ul style="list-style-type: none"> • 68-pin QFJ • 68-pin PGA • 80-pin QFP
μ PD70216	V50™		16 bits	16 bits			
μ PD70208H	V40HL™	<u>V40/V50 upper compatible, high speed low voltage operation</u> <ul style="list-style-type: none"> • Capable of operating at 20 MHz (at 5 V) • Capable of operating at 3 V (at 10 MHz) • Selectable clock frequency • Enhanced peripheral functions 	16 bits	8 bits	1M bytes	10/12.5/16/20 MHz	<ul style="list-style-type: none"> • 68-pin QFJ • 80-pin QFP • 80-pin TQFP
μ PD70216H	V50HL™		16 bits	16 bits			
μ PD70236A	V53A™	<u>V33A + enhanced peripheral functions of V40/V50</u> <ul style="list-style-type: none"> • DMA capable of supporting 16MB space • Dedicated BRG for timer/counter • Low power control <ul style="list-style-type: none"> · Stop mode · Halt mode · Variable clock mode • Capable of operating at 3 V and 10 MHz (only for V53A) • Capable of operating at 4 V and 16 MHz (only for V53A) 	16 bits	8/16 bits (Selectable)	16M bytes	10/12.5/16/20 MHz	<ul style="list-style-type: none"> • 132-pin PGA • 120-pin QFP (0.8, 0.5 or 0.4 mm pin pitch)

V Series

■ **16-Bit (2/2)**

Type number	Alias	Features	Internal bus	External bus	Real memory space	Operating frequency	Package
μ PD70270	V41™	V20HL/30HL + Peripheral control unit Each product is a microcomputer with a CPU core comprising NEC's "V20HL/V30HL" and peripheral circuits compatible with PC/XT™ • EMS Ver 4.0 support circuit • DMA control unit (equivalent to μ PD71037)	16 bits	8 bits	16M bytes	16 MHz	• 160-pin QFP
μ PD70280	V51™	• Interrupt control unit (equivalent to μ PD71059) • Timer/counter unit (equivalent to μ PD71037) • Keyboard control unit • Memory control unit • External I/O decoder • ROM decoder	16 bits	16 bits			
μ PD70433	V55P1™	Software compatible with V20/30/25/35 • 16 general purpose register banks (512-byte internal RAM) Following various peripheral features for mechanical control • Multi-mode interrupt controller (Vectored/Register bank switching/Macro service) • 2 real time output ports for controlling stepping motors • 8-bit A/D converter with 4 inputs • 2 DMA controllers with intelligent modes • 5 16-bit timer/counters • 2 asynchronous/synchronous serial controllers • 8-bit parallel interface • Watchdog timer • MH/MR codec instructions	16 bits	8/16 bits (Selectable)	16M bytes	12.5/16 MHz	• 120-pin QFP (0.8 or 0.5 mm pin pitch) • 132-pin PGA
μ PD70320	V25™	Software compatible with V20/V30. Following additional peripheral features including RAM: • 2-ch DMA controller • 2-ch serial controller • 2-ch 16-bit timer/counter • Interrupt controller	16 bits	8 bits	1M bytes	8 MHz	• 84-pin QFJ • 94-pin QFP
μ PD70330	V35™	• 24 general purpose I/O port pins • 8 general purpose register banks • RAM 256B	16 bits	16 bits			
μ PD79011	V25HS™	CPU with built-in RTOS (internal ROM of V25/V35 to which real-time OS is transplanted)	16 bits	8 bits	1M bytes	8 MHz	• 84-pin QFJ • 94-pin QFP
μ PD79021	V35HS™		16 bits	16 bits			
μ PD70325	V25+™	High speed version of V25/V35 DMA transfer function	16 bits	8 bits	1M bytes	8/10 MHz	• 84-pin QFJ • 94-pin QFP
μ PD70335	V35+™		16 bits	16 bits			

V Series

■ 32-Bit

Type number	Alias	Features	Address/data bus	Memory space	Operating frequency	Package
μ PD70616	V60™	<ul style="list-style-type: none"> • Virtual memory (paging method) • Level protection architecture • 4-level hierarchical protection function for system multi-programming. • Abundant general registers • Thirty two 32-bit general registers for optimizing compiler • Refined instruction set • 2-address method: Arbitrary addressing mode can be used independently for source operand and destination operand. 	24 bits/ 16 bits	4G bytes	16 MHz	• 68-pin PGA
μ PD70632	V70™	<ul style="list-style-type: none"> • Abundant address modes and data types • Auto increment/decrement mode for string process, and memory indirect addressing for pointer operation • Multiprocessor system • FRM function for increasing system reliability using two or more processors. • V20/V30 simulation mode 	32 bits/ 32 bits		20 MHz	<ul style="list-style-type: none"> • 132-pin PGA • 200-pin QFP
μ PD70615	V60	<ul style="list-style-type: none"> • Identical with μPD70616 except that FRM function and V20/V30 emulation function are eliminated. High cost-to-performance chip 	24 bits/ 16 bits		16 MHz	• 120-pin QFP

V Series

■ 32-Bit RISC V800 Series product evolution

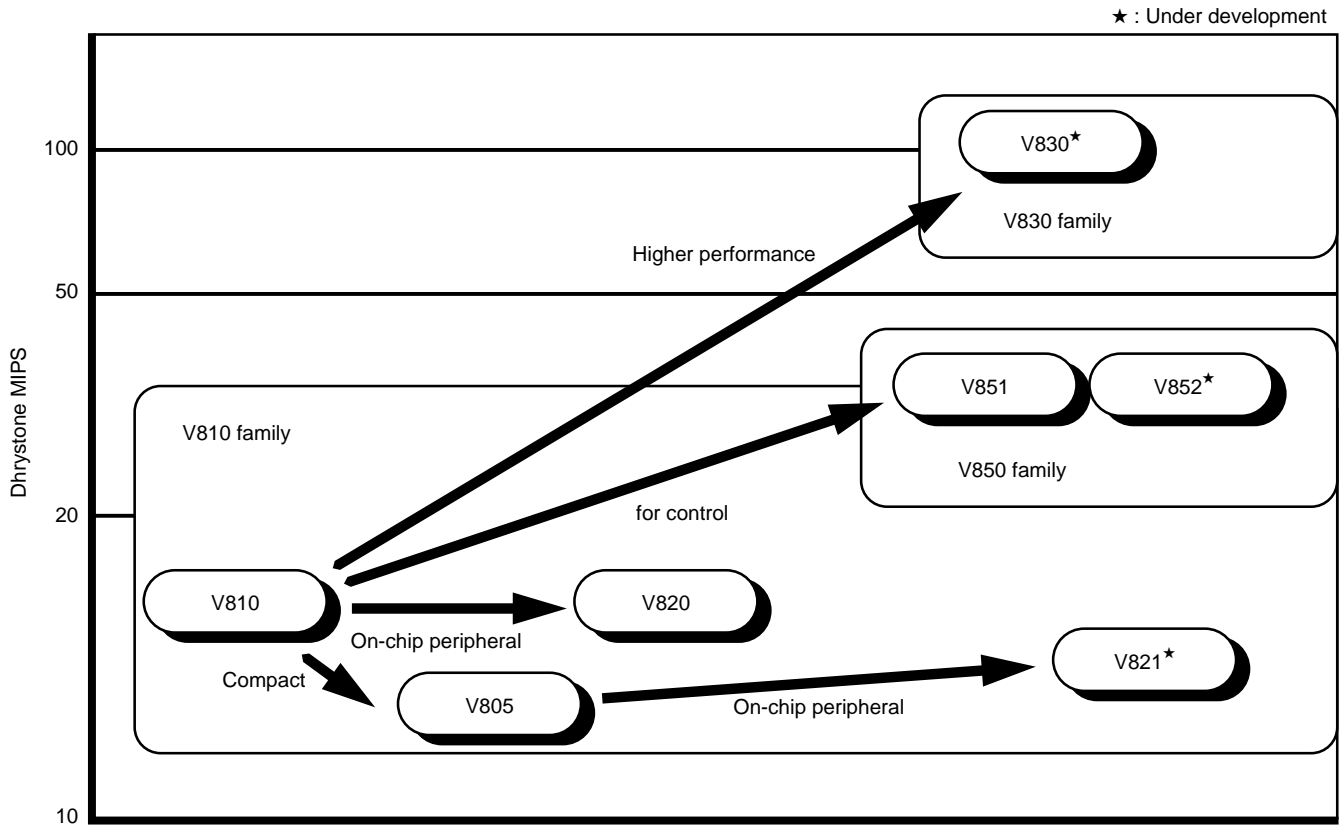

V Series

■ 32-Bit RISC – V800 Series –

Type number	Alias	Features	Address/data bus	Memory space	Performance/frequency	Package
μ PD70732	V810™	<ul style="list-style-type: none"> 32-bit RISC architecture 1-instruction/clock with 5-stage pipeline 32 32-bit general purpose registers 1K-byte instruction cache Operation supply voltage 2.2 to 5.5 V Consumption power (TYP.) 500mW (V810 5 V, 25 MHz) 280mW (V805 5 V, 20 MHz) 	32 bits/ 32 bits	4G bytes	18MIPS/25 MHz (Dhrystone)	<ul style="list-style-type: none"> 120-pin QFP 176-pin PGA
μ PD70731	V805™	<ul style="list-style-type: none"> V810 core + peripheral controllers 2-ch Serial I/O 3-ch 16-bit timer/counter 4-ch 32-bit DMA controller Access controller Interrupt controller Clock generator 	32 bits/ 16 bits		13MIPS/20 MHz (Dhrystone)	<ul style="list-style-type: none"> 100-pin QFP
μ PD70742	V820™	<ul style="list-style-type: none"> V810 core + peripheral controllers Memory controller (DRAM, Page-ROM) 2-ch Serial I/O (UARTx1, CS1x1) 2-ch 16-bit timer/counter 2-ch DMA controller Interrupt controller Watchdog timer 	32 bits/ 32 bits		18MIPS/25 MHz (Dhrystone)	<ul style="list-style-type: none"> 208-pin QFP 280-pin PGA
μ PD70741*	V821™	<ul style="list-style-type: none"> High-performance RISC processor (V830 core) Multiplier (32 \times 32 \rightarrow 64-bit) Internal memory 4K-byte instruction cache 4K-byte data cache 4K-byte RAM for instruction 4K-byte RAM for data Consumption power (TARGET) 500mW (3.3 V, 100 MHz) 	24 bits/ 16 bits	4G bytes (Internal) 64M bytes (external MAX)	16MIPS/25 MHz (Dhrystone)	<ul style="list-style-type: none"> 100-pin QFP
μ PD705100*	V830™	<ul style="list-style-type: none"> 32-bit RISC (V850 core) 1 chip microcomputer Multiplier (16 \times 16 \rightarrow 32-bit) Internal memory 32K-byte ROM (μPD703001: ROM less), 1K-byte RAM 2-ch Serial I/O (UARTx1, CS1x1) 2-ch 16-bit timer/counter Interrupt controller Operation supply voltage 2.0 to 5.5 V (Mask ROM, ROM less) 2.7 to 5.5 V (PROM) Consumption power (TYP.) 207mW (5 V, 25 MHz), 267mW (5 V, 33 MHz)* 	32 bits/ 32 bits	4G bytes	118MIPS/100 MHz (Dhrystone)	<ul style="list-style-type: none"> 144-pin QFP
μ PD703000/ 70P3000/ 703001	V851™	<ul style="list-style-type: none"> 32-bit RISC (V850 core) 1 chip microcomputer Multiplier (16 \times 16 \rightarrow 32-bit) Internal memory 90K-byte ROM, 3K-byte RAM 4-ch Serial I/O (UARTx1, CS1x3) 2-ch 16-bit timer/counter Interrupt controller Operation supply voltage 2.0 to 5.5 V (Mask ROM) 2.7 to 5.5 V (PROM) Low consumption power 	24 bits/ 16 bits	4G bytes (Internal) 16M bytes (external MAX)	29MIPS/25 MHz 38MIPS/33 MHz* (Dhrystone, Except μ PD703001)	<ul style="list-style-type: none"> 100-pin QFP (μPD703000/ 70P3000/ 703001) 120-pin WQFN (μPD70P3000)
μ PD703002*/ 70P3002	V852™	<ul style="list-style-type: none"> 32-bit RISC (V850 core) 1 chip microcomputer Multiplier (16 \times 16 \rightarrow 32-bit) Internal memory 90K-byte ROM, 3K-byte RAM 4-ch Serial I/O (UARTx1, CS1x3) 2-ch 16-bit timer/counter Interrupt controller Operation supply voltage 2.0 to 5.5 V (Mask ROM) 2.7 to 5.5 V (PROM) Low consumption power 	24 bits/ 16 bits	4G bytes (Internal) 16M bytes (external MAX)	29MIPS/25 MHz (Dhrystone)	<ul style="list-style-type: none"> 100-pin QFP (μPD703000/ 70P3000) 120-pin WQFN (μPD70P3002)

*: Under development

VR Series™

Type number	Alias	Features	Address/ data bus	Virtual memory space	Performance	Package
μPD30400	V _R 4000PC™	<ul style="list-style-type: none"> • 64-bit architecture • 2 operation per 1 clock execution with superpipelined processing • On chip floating point processing unit • On chip primary cache memory (instruction 8K + data 8K Byte) • Software upppered compatible with VR3000A • Internal 100 MHz, external 50 MHz operation 	36/64	Kernel: 16EXA bytes User : 64G bytes	41 SPEC int92 43 SPEC fp92 (Internal 100 MHz)	• 179-pin PGA
μPD30401	V _R 4000SC™	<ul style="list-style-type: none"> • Same function with V_R4000PC, furthermore on chip secondary cache memory controller supported • Internal 100 MHz, external 50 MHz operation 	36/64	Kernel: 16EXA bytes User : 64G bytes	62 SPEC int92 63 SPEC fp92 (Internal 100 MHz)	• 447-pin PGA
μPD30410	V _R 4400PC™	<ul style="list-style-type: none"> • V_R4000PC compatible • On chip primary cache (I16KB + D16KB) • Internal 200 MHz, external 100 MHz operation★ 	36/64	Kernel: 16EXA bytes User : 64G bytes	83 SPEC int92 92 SPEC fp92 (Internal 200 MHz)	• 179-pin PGA
μPD30412	V _R 4400MC™	<ul style="list-style-type: none"> • Same function with V_R4400PC, furthermore on chip secondary cache memory controller and correspond to multiprocessing system supported 	36/64	Kernel: 16EXA bytes User : 64G bytes	141 SPEC int92 143 SPEC fp92 (Internal 200 MHz)	• 447-pin PGA
μPD30450	V _R 4200™	<ul style="list-style-type: none"> • V_R4000PC compatible • Low power (1.5 W typ) • On chip primary cache (I16KB + D8KB) • Internal 80 MHz, external 40 MHz operation 	33/64	Kernel: 16EXA bytes User : 8G bytes	55 SPEC int92 30 SPEC fp92 (Internal 80 MHz)	• 208-pin QFP • 179-pin PGA
μPD30100★	V _R 4100™	<ul style="list-style-type: none"> • Low poewr (100 mW @33 MHz, 2.2 V) • 2 level power management • 64 bit architecture • On chip MMU 	32/32	Kernel: 16EXA bytes User : 4G bytes	40 MIPS (Internal 133 MHz)	• 100-pin QFP
μPD30200★	V _R 4300™	<ul style="list-style-type: none"> • High speed operation from 100 MHz pipe • Large on chip cache I16K + D8K byte • 64 bit architecture • High speed floating operation • On chip MMU 	32/32	Kernel: 16EXA bytes User : 4G bytes	70 SPEC int 45 SPEC fp92 (Internal 100 MHz)	• 120-pin QFP

★: Under development

Microcomputer Peripheral LSI

Type number	Process	Function	Supply voltage	Clock frequency	Package	Remarks
μ PD77C30	CMOS	PCM \times ADPCM (Coding/decoding)	+5 V	8.192 MHz	<ul style="list-style-type: none"> • 28-pin DIP • 44-pin QFJ 	—

■ V series peripheral LSI

Type number	Process	Function	Supply voltage	Package
μ PD71037	CMOS	8-bit DMA controller	+5 V	<ul style="list-style-type: none"> • 40-pin DIP • 44-pin QFJ • 44-pin QFP
μ PD71051		Serial control unit		<ul style="list-style-type: none"> • 28-pin SOP • 44-pin QFP • 28-pin DIP • 28-pin QFJ
μ PD71054		Programmable timer/counter		<ul style="list-style-type: none"> • 24-pin DIP • 28-pin QFJ • 44-pin QFP
μ PD71055		Parallel interface unit		<ul style="list-style-type: none"> • 40-pin DIP • 44-pin QFP • 44-pin QFJ
μ PD71059		Interrupt control unit		<ul style="list-style-type: none"> • 28-pin SOP • 44-pin QFP • 28-pin DIP • 44-pin QFJ
μ PD71071		16-bit DMA controller		<ul style="list-style-type: none"> • 48-pin DIP • 52-pin QFJ • 52-pin QFP
μ PD71082		8-bit latch Non-invert type		<ul style="list-style-type: none"> • 20-pin DIP • 20-pin SOP
μ PD71083		8-bit latch Invert type		
μ PD71011		Clock generator		<ul style="list-style-type: none"> • 18-pin DIP • 20-pin SOP
μ PD71084		Clock generator		<ul style="list-style-type: none"> • 18-pin DIP • 20-pin SOP
μ PD71086		8-bit bus transceiver Non-invert type		<ul style="list-style-type: none"> • 20-pin DIP • 20-pin SOP
μ PD71087		8-bit bus transceiver Invert type		
μ PD71088		Bus controller		
μ PD71101		Composite peripheral LSI integrating μ PD71051 ∞ 2, μ PD71054, μ PD71055, μ PD71059, and BRG		<ul style="list-style-type: none"> • 120-pin QFP
μ PD71611		Clock generator for V60		<ul style="list-style-type: none"> • 20-pin DIP
μ PD71613		System controller for V60		
μ PD71621		Clock generator for V70		
μ PD71641		Cache memory controller		
μ PD72291		Floating point processor		<ul style="list-style-type: none"> • 132-pin PGA
μ PD72691	<ul style="list-style-type: none"> • 68-pin PGA 			

■ VR series peripheral LSI

Type number	Process	Function	Supply voltage	Package
μ PD30311 (VR3010A)	CMOS	Floating point coprocessor (40/33 MHz operation)	+5 V	<ul style="list-style-type: none"> • 84-pin PGA • 84-pin PPGA
μ PD31441		Chip set for Vr4000, Vr4200, Vr4400	+3.3 V	<ul style="list-style-type: none"> • 240-pin QFP
μ PD31442				

EMPTY PAGE

IC Memory

Dynamic RAM	64	2
Dynamic RAM Module	72	
Static RAM	75	
Mask ROM	78	
PROM	79	
Flash MEMORY	80	
Other	81	
• Dual-Port Graphic Buffer.....	81	
• Synchronous Graphics RAM	81	
• Graphic Memory	81	
• Silicon File	82	
• Field/Line Buffer	82	

Dynamic RAM

■ **Low Voltage Operation 64M Dynamic RAM**

Organization (words ∞ bits)	Part number	Access time MAX. (ns)	Refresh cycle (cycles/ ms)	Maximum supply current		Supply voltage (V)	Package	Remarks
				Active (mA)	Standby (mA)			
16M ∞ 4	μPD4264400	50 60 70	8K/64*	100 90 80	0.5	3.3±0.3	• 32-pin SOJ (400 mil) • 32-pin TSOP II (400 mil)	Fast page
	μPD4265400	50 60 70	4K/64	130 110 100				
8M ∞ 8	μPD4264800	50 60 70	8K/64*	105 95 85	0.5	3.3±0.3	• 32-pin SOJ (400 mil) • 32-pin TSOP II (400 mil)	-
	μPD4265800	50 60 70	4K/64	135 115 105				
4M ∞ 16	μPD4264160	50 60 70	8K/64*	110 100 90	0.5	3.3±0.3	• 50-pin TSOP II (400 mil)	Fast page + Byte read/write
	μPD4265160	50 60 70	4K/64	140 120 110				

* CBR/Hidden Refresh: 4K/64

■ **Low Voltage Operation 64M Dynamic RAM with Self Refresh**

Organization (words ∞ bits)	Part number	Access time MAX. (ns)	Refresh cycle (cycles/ ms)	Maximum supply current				Supply voltage (V)	Package	Remarks
				Active (mA)	Standby (mA)	Self refresh (μA)	Long refresh (μA)			
16M ∞ 4	μPD42S64400*	50 60 70	8K/128*	100 90 80	0.2	300	300	3.3±0.3	• 32-pin SOJ (400 mil) • 32-pin TSOP II (400 mil)	Fast page
	μPD42S65400*	50 60 70	4K/128	130 110 100						
8M ∞ 8	μPD42S64800*	50 60 70	8K/128*	105 95 85	0.2	300	300	3.3±0.3	• 32-pin SOJ (400 mil) • 32-pin TSOP II (400 mil)	Fast page
	μPD42S65800*	50 60 70	4K/128	135 115 105						
4M ∞ 16	μPD42S64160*	50 60 70	8K/128*	110 100 90	0.2	300	300	3.3±0.3	• 50-pin TSOP II (400 mil)	Fast page
	μPD42S65160*	50 60 70	4K/128	140 120 110						

* CBR/Hidden Refresh: 4K/128

★: Under development

Dynamic RAM

■ 16M Dynamic RAM

Organization (words ∞ bits)	Part number	Access time MAX. (ns)	Refresh cycle (cycles/ ms)	Maximum supply current		Supply voltage (V)	Package	Remarks
				Active (mA)	Standby (mA)			
4M ∞ 4	μ PD4216400	50 60 70 80	4K/64	100 90 80 70	1	5±10 %	<ul style="list-style-type: none"> • 26-pin SOJ (300 mil) • 26-pin TSOP II (300 mil) 	Fast page
	μ PD4217400	50 60 70 80	2K/32	10 110 100 90				
2M ∞ 8	μ PD4216800	50 60 70 80	4K/64	100 90 80 70			<ul style="list-style-type: none"> • 28-pin SOJ (400 mil) • 28-pin TSOP II (400 mil) 	
	μ PD4217800	50 60 70 80	2K/32	120 110 100 90				
1M ∞ 16	μ PD4216160	60 70 80	4K/64	100 90 80			<ul style="list-style-type: none"> • 42-pin SOJ (400 mil) • 50-pin TSOP II (400 mil) 	Fast page + Byte read/write
	μ PD4218160	60 70 80	1K/16	160 150 140				

■ 16M Dynamic RAM with Self Refresh
--

Organization (words ∞ bits)	Part number	Access time MAX. (ns)	Refresh cycle (cycles/ ms)	Maximum supply current				Supply voltage (V)	Package	Remarks
				Active (mA)	Standby (mA)	Self refresh (μ A)	Long refresh (μ A)			
4M ∞ 4	μ PD42S16400	50 60 70 80	4K/128	100 90 80 70	0.25	250	450	5±10 %	<ul style="list-style-type: none"> • 26-pin SOJ (300 mil) • 26-pin TSOP II (300 mil) 	Fast page
	μ PD42S17400	50 60 70 80	2K/128	120 110 100 90						
2M ∞ 8	μ PD42S16800	50 60 70 80	4K/128	100 90 80 70			450		<ul style="list-style-type: none"> • 28-pin SOJ (400 mil) • 28-pin TSOP II (400 mil) 	
	μ PD42S17800	50 60 70 80	2K/128	120 110 100 90						
1M ∞ 16	μ PD42S16160	60 70 80	4K/128	100 90 80			450		<ul style="list-style-type: none"> • 42-pin SOJ (400 mil) • 50-pin TSOP II (400 mil) 	Fast page + Byte read/write
	μ PD42S18160	60 70 80	1K/128	160 150 140						

Dynamic RAM

■ **Low Voltage Operation 16M Dynamic RAM**

Organization (words ∞ bits)	Part number	Access time MAX. (ns)	Refresh cycle (cycles/ ms)	Maximum supply current		Supply voltage (V)	Package	Remarks	
				Active (mA)	Standby (mA)				
4M ∞ 4	μPD4216400L	60 70 80	4K/64	80 70 60	0.5	3.3±0.3	<ul style="list-style-type: none"> • 26-pin SOJ (300 mil) • 26-pin TSOP II (300 mil) 	Fast page	
	μPD4217400L	60 70 80	2K/32	100 90 80					
2M ∞ 8	μPD4216800L	60 70 80	4K/64	80 70 60	0.5		<ul style="list-style-type: none"> • 28-pin SOJ (400 mil) • 28-pin TSOP II (400 mil) 	-	
	μPD4217800L	60 70 80	2K/32	100 90 80					
1M ∞ 16	μPD4216160L	60 70 80	4K/64	90 80 70			0.5	<ul style="list-style-type: none"> • 42-pin SOJ (400 mil) • 50-pin TSOP II (400 mil) 	Fast page + Byte read/write
	μPD4218160L	60 70 80	1K/16	150 140 130					

■ **Low Voltage Operation 16M Dynamic RAM with Self Refresh**

Organization (words ∞ bits)	Part number	Access time MAX. (ns)	Refresh cycle (cycles/ ms)	Maximum supply current				Supply voltage (V)	Package	Remarks		
				Active (mA)	Standby (mA)	Self refresh (μA)	Long refresh (μA)					
4M ∞ 4	μPD42S16400L	60 70 80	4K/128	80 70 60	0.15	150	220	3.3±0.3	<ul style="list-style-type: none"> • 26-pin SOJ (300 mil) • 26-pin TSOP II (300 mil) 	Fast page		
	μPD42S17400L	60 70 80	2K/128	100 90 80							200	
2M ∞ 8	μPD42S16800L	60 70 80	4K/128	80 70 60	0.15	150	220		<ul style="list-style-type: none"> • 28-pin SOJ (400 mil) • 28-pin TSOP II (400 mil) 			
	μPD42S17800L	60 70 80	2K/128	100 90 80							200	
1M ∞ 16	μPD42S16160L	60 70 80	4K/128	90 80 70			0.15		150	220	<ul style="list-style-type: none"> • 42-pin SOJ (400 mil) • 50-pin TSOP II (400 mil) 	Fast page + Byte read/write
	μPD42S18160L	60 70 80	1K/128	150 140 130								

Dynamic RAM

■ 16M Dynamic RAM (Hyper Page Mode*)

Organization (words ∞ bits)	Part number	Access time MAX. (ns)	Refresh cycle (cycles/ ms)	Maximum supply current		Supply voltage (V)	Package	Remarks
				Active (mA)	Standby (mA)			
4M ∞ 4	μ PD4216405	50 60 70 80	4K/64	100 90 80 70	1	5±10 %	<ul style="list-style-type: none"> • 26-pin SOJ (300 mil) • 26-pin TSOP II (300 mil) 	Hyper page
	μ PD4217401	50 60 70 80	2K/32	10 110 100 90				
2M ∞ 8	μ PD4217801	50 60 70 80	2K/32	120 110 100 90			<ul style="list-style-type: none"> • 28-pin SOJ (400 mil) • 28-pin TSOP II (400 mil) 	
1M ∞ 16	μ PD4216161	60 70 80	4K/64	100 90 80			<ul style="list-style-type: none"> • 42-pin SOJ (400 mil) • 50-pin TSOP II (400 mil) 	Hyper page + Byte read/write
	μ PD4218161	60 70 80	1K/16	160 150 140				

*: Hyper Page Mode is equivalent to EDO

■ 16M Dynamic RAM with Self Refresh (Hyper Page Mode*)

Organization (words ∞ bits)	Part number	Access time MAX. (ns)	Refresh cycle (cycles/ ms)	Maximum supply current				Supply voltage (V)	Package	Remarks
				Active (mA)	Standby (mA)	Self refresh (μ A)	Long refresh (μ A)			
4M ∞ 4	μ PD42S16405	50 60 70 80	4K/128	100 90 80 70	0.25	250	450	5±10 %	<ul style="list-style-type: none"> • 26-pin SOJ (300 mil) • 26-pin TSOP II (300 mil) 	Hyper page
	μ PD42S17401	50 60 70 80	2K/128	120 110 100 90						
2M ∞ 8	μ PD42S17801	50 60 70 80	2K/128	120 110 100 90			400		<ul style="list-style-type: none"> • 28-pin SOJ (400 mil) • 28-pin TSOP II (400 mil) 	
1M ∞ 16	μ PD42S16161	60 70 80	4K/128	100 90 80			450		<ul style="list-style-type: none"> • 42-pin SOJ (400 mil) • 50-pin TSOP II (400 mil) 	Hyper page + Byte read/write
	μ PD42S18161	60 70 80	1K/128	160 150 140			350			

*: Hyper Page Mode is equivalent to EDO

Dynamic RAM

■ **Low Voltage Operation 16M Dynamic RAM (Hyper Page Mode*)**

Organization (words ∞ bits)	Part number	Access time MAX. (ns)	Refresh cycle (cycles/ ms)	Maximum supply current		Supply voltage (V)	Package	Remarks
				Active (mA)	Standby (mA)			
4M ∞ 4	μPD42164005L	60 70 80	4K/64	80 70 60	0.5	3.3±0.3	• 26-pin SOJ (300 mil) • 26-pin TSOP II (300 mil)	Hyper page
	μPD4217401L	60 70 80	2K/32	100 90 80				
2M ∞ 8	μPD4217801L	60 70 80	2K/32	100 90 80			• 28-pin SOJ (400 mil) • 28-pin TSOP II (400 mil)	–
1M ∞ 16	μPD4216161L	60 70 80	4K/64	90 80 70			• 42-pin SOJ (400 mil) • 50-pin TSOP II (400 mil)	Hyper page + Byte read/write
	μPD4218161L	60 70 80	1K/16	150 140 130				

*: Hyper Page Mode is equivalent to EDO

■ **Low Voltage Operation 16M Dynamic RAM with Self Refresh (Hyper Page Mode*)**

Organization (words ∞ bits)	Part number	Access time MAX. (ns)	Refresh cycle (cycles/ ms)	Maximum supply current				Supply voltage (V)	Package	Remarks
				Active (mA)	Standby (mA)	Self refresh (μA)	Long refresh (μA)			
4M ∞ 4	μPD42S16401L	60 70 80	4K/128	80 70 60	0.15	150	220	3.3±0.3	• 26-pin SOJ (300 mil) • 26-pin TSOP II (300 mil)	Hyper page
	μPD42S17401L	60 70 80	2K/128	100 90 80						
2M ∞ 8	μPD42S17801L	60 70 80	2K/128	100 90 80			200		• 28-pin SOJ (400 mil) • 28-pin TSOP II (400 mil)	
1M ∞ 16	μPD42S16161L	60 70 80	4K/128	90 80 70			220		• 42-pin SOJ (400 mil) • 50-pin TSOP II (400 mil)	Hyper page + Byte read/write
	μPD42S18161L	60 70 80	1K/128	150 140 130			180			

*: Hyper Page Mode is equivalent to EDO

Dynamic RAM

■ 4M Dynamic RAM

Organization (words ∞ bits)	Part number	Access time MAX. (ns)	Refresh cycle (cycles/ ms)	Maximum supply current			Supply voltage (V)	Package	Remarks
				Active (ms)	Standby (mA)	Long refresh (μ A)			
1M ∞ 4	μ PD424400	60 70	1K/16	120 100	1	–	5 \pm 10 %	• 26-pin SOJ (300 mil) • 26-pin TSOP II (300 mil)	Fast page
	μ PD424400-L	60 70	1K/128	120 100	0.2	300			
512K ∞ 8	μ PD424800	60 70 80	1K/16	105 105 95	1	–		• 28-pin SOJ (400 mil) • 28-pin TSOP II (400 mil)	
256K ∞ 16	μ PD424260	60 70 80	512/8	160 160 145			• 40-pin SOJ (400 mil) • 44-pin TSOP II (400 mil)	Fast page Byte read/write	

■ 4M Dynamic RAM with Self Refresh

Organization (words ∞ bits)	Part number	Access time MAX. (ns)	Refresh cycle (cycles/ ms)	Maximum supply current				Supply voltage (V)	Package	Remarks
				Active (ms)	Standby (mA)	Self refresh (μ A)	Long refresh (μ A)			
1M ∞ 4	μ PD42S4400	60 70	1K/128	120 100	0.15	150	200	5 \pm 10 %	• 26-pin SOJ (300 mil) • 26-pin TSOP II (300 mil)	Fast page
512K ∞ 8	μ PD42S4800	60 70 80	1K/128	105 105 95						
256K ∞ 16	μ PD42S4260	60 70 80	512/128	160 160 145					• 40-pin SOJ (400 mil) • 44-pin TSOP II (400 mil)	

■ Low Voltage Operation 4M Dynamic RAM

Organization (words ∞ bits)	Part number	Access time MAX. (ns)	Refresh cycle (cycles/ ms)	Maximum supply current		Supply voltage (V)	Package	Remarks
				Active (ms)	Standby (mA)			
256K ∞ 16	μ PD424260AL	60 70 80	512/8	80 70 60	0.5	3.3 \pm 0.3	• 40-pin SOJ (400 mil) • 44-pin TSOP II (400 mil)	Fast page Byte read/write

■ Low Voltage Operation 4M Dynamic RAM with Self Refresh

Organization (words ∞ bits)	Part number	Access time MAX. (ns)	Refresh cycle (cycles/ ms)	Maximum supply current				Supply voltage (V)	Package	Remarks
				Active (ms)	Standby (mA)	Self refresh (μ A)	Long refresh (μ A)			
256K ∞ 16	μ PD42S4260AL	60 70 80	512/128	80 70 60	0.08	80	100	3.3 \pm 0.3	• 40-pin SOJ (400 mil) • 44-pin TSOP II (400 mil)	Fast page Byte read/write

Dynamic RAM

■ 4M Dynamic RAM (Hyper Page Mode*)

Organization (words ∞ bits)	Part number	Access time MAX. (ns)	Refresh cycle (cycles/ ms)	Maximum supply current			Supply voltage (V)	Package	Remarks
				Active (ms)	Standby (mA)	Long refresh (μ A)			
256K ∞ 16	μ PD424210	60-G 70	512/8	160 150	1	–	5 \pm 10 %	• 40-pin SOJ (400 mil) • 44-pin TSOP II (400 mil)	Hyperpage Byte read/write

*: Hyper Page Mode is equivalent to EDO

■ 4M Dynamic RAM with Self Refresh (Hyper Page Mode*)

Organization (words ∞ bits)	Part number	Access time MAX. (ns)	Refresh cycle (cycles/ ms)	Maximum supply current				Supply voltage (V)	Package	Remarks
				Active (ms)	Standby (mA)	Self refresh (μ A)	Long refresh (μ A)			
256K ∞ 16	μ PD42S4210	60-G 70	512/128	160 150	0.15	150	200	5 \pm 10 %	• 40-pin SOJ (400 mil) • 44-pin TSOP II (400 mil)	Hyperpage Byte read/write

*: Hyper Page Mode is equivalent to EDO

■ Low Voltage Operation 4M Dynamic RAM (Hyper Page Mode*)

Organization (words ∞ bits)	Part number	Access time MAX. (ns)	Refresh cycle (cycles/ ms)	Maximum supply current		Supply voltage (V)	Package	Remarks
				Active (ms)	Standby (mA)			
256K ∞ 16	μ PD424210AL	60 70 80	512/8	80 70 60	0.5	3.3 \pm 0.3	• 40-pin SOJ (400 mil) • 44-pin TSOP II (400 mil)	Hyperpage Byte read/write

*: Hyper Page Mode is equivalent to EDO

■ Low Voltage Operation 4M Dynamic RAM with Self Refresh (Hyper Page Mode*)

Organization (words ∞ bits)	Part number	Access time MAX. (ns)	Refresh cycle (cycles/ ms)	Maximum supply current				Supply voltage (V)	Package	Remarks
				Active (ms)	Standby (mA)	Self refresh (μ A)	Long refresh (μ A)			
256K ∞ 16	μ PD42S4210AL	60 70 80	512/128	80 70 60	0.08	80	100	3.3 \pm 0.3	• 40-pin SOJ (400 mil) • 44-pin TSOP II (400 mil)	Hyperpage Byte read/write

*: Hyper Page Mode is equivalent to EDO

Dynamic RAM

■ Synchronous DRAM

Organization (words ∞ bits)	Part number	Cycle time MIN. (ns)	Refresh cycle (cycles/ ms)	Maximum supply current			Inter- face	Supply voltage (V)	Package
				Active Normal/Burst (Grade-10, C.L.=3) (mA)	Standby (Power down Mode) (mA)	Self refresh (mA)			
4M ∞ 4	μ PD4516421	10 (100 MHz)	2K/32	80 mA/150 mA (MAX.)	2	2	LVTTTL	3.3±0.3	• 44-pin TSOP II (400 mil)
2M ∞ 8	μ PD4516821	12 (83 MHz) 13 (75 MHz)		85 mA/165 mA (MAX.)					
1M ∞ 16	μ PD4516161	15 (66 MHz)		90 mA/210 mA (MAX.)					

C.L. = CAS Latency

■ Rambus™ DRAM (under development)

Organization (words ∞ bits)	Part number		Operating frequency (MHz)	Supply voltage (V)	Maximum supply current (mA)	Package
2M ∞ 9	μ PD488170L	-A50	250	3.3 ±0.15	250	• 32-pin SVP • 72/36-pin SSOP
		-A40	200			
2M ∞ 8	μ PD488130L	-A50	250			
		-A40	200			

Dynamic RAM Module

■ SIMM

Capacity (byte)	Organiza- tion (words ∞ bits)	Part number	Access time MAX. (ns)	Maximum supply current		Supply voltage (V)	Package	Remarks
				Active (mA)	Standby (mA)			
32M	8M ∞ 36	MC-428000A36	60 70 80	1420 1260 1140	24	5±10 %	• 72-pin SIMM socket type (solder-coated/gold-plated)	Fast page
		MC-428000A32	60 70 80	860 780	16			
	MC-428000F32	60 70	940 860	16	Hyper page (EDO)			
16M	4M ∞ 36	MC-424000A36	60 70 80	1360 1200 1080	12		• 72-pin SIMM socket type socket type (solder-coated/gold-plated)	Fast page
		MC-424000A32	60 70 80	880 800 720	8			
	MC-424000F32	60 70	880 800	8	Hyper page (EDO)			
8M	2M ∞ 36	MC-422000A36	60 70 80 100	1300 1180 1060 940	24			Fast page
		MC-422000A32	60 70 80	324 304 284	4			
	MC-422000F32	60 70	324 304	4	Hyper page (EDO)			
4M	1M ∞ 36	MC-421000A36	60 70 80 100	1240 1120 1000 880	12		• 72-pin SIMM socket type socket type (solder-coated/gold-plated)	Fast page
		MC-421000A32	60 70 80	320 300 280	2			
	MC-421000F32	60 70	320 300	2	Hyper page (EDO)			

■ SOD (SOD: Small Outline DIMM, DIMM: Dual Inline Memory Module)

Organiza- tion (words ∞ bits)	Bank	Part number	Access time MAX. (ns)	Refresh cycle (cycles/ ms)	Maximum supply current			Supply voltage (V)	Package	Mounted devices	Remarks
					Active (mA)	Standby (mA)	Self refresh (μA)				
1M ∞ 32	1	MC-42S1000LAD32S	60 70 80	1K/128	300	1	360	3.3±0.3	• 72-pin SOD Socket type (Gold plated)	D42S18160LG5 ∞ 2 pcs.	Fast page Self refresh
					280 260						
2M ∞ 32	1	MC-42S2000LAB32S	60 70 80	2K/128	400	2	600			D42S17800LG5 ∞ 4 pcs.	
					360 320						
4M ∞ 32	2	MC-42S2000LAD32S	60 70 80	1K/128	301		720			D42S18160LG5 ∞ 4 pcs.	
					281 261						
4M ∞ 32	1	MC-42S4000LAC32S	60 70 80	2K/128	800	4	1200			D42S17400LG3 ∞ 8 pcs.	
					720 640						
4M ∞ 32	2	MC-42S4000LAB32S	60 70 80		405		1200			D42S17800LG5 ∞ 8 pcs.	
					365 325						

Dynamic RAM Module

■ 8 Byte DIMM (DIMM: Dual Inline Memory Module)

Organization (words ∞ bits)	Part number	Access time MAX. (ns)	Refresh cycle (cycles/ ms)	Maximum supply current		Supply voltage (V)	Package	Remarks
				Active (mA)	Standby (mA)			
1M ∞ 64	MC-421000AA64	60 70 80	1K/16	650 610 570	68	5.0±0.25	• 168-pin DIMM Socket type (Gold plated)	Fast page
	MC-421000FA64	60 70		650 610				Hyper page (EDO)
2M ∞ 64	MC-422000AA64	60 70 80		660 620 580	72			Fast page
	MC-422000FA64	60 70		660 620				
1M ∞ 72 (ECC)	MC-421000AD72	60 70 80		890 810 750	70			Fast page
2M ∞ 72 (ECC)	MC-422000AB72	60 70 80		1000 910 820	73			Fast page
	MC-422000FB72	60 70		1000 910				
	MC-422000LAB72	60 70 80		910 820 730	14			3.3±0.3
	MC-422000LFB72	60 70	910 820	Hyper page (EDO)				
4M ∞ 72 (ECC)	MC-424000AB72	60 70 80	1990 1810 1630	82	5.0±0.25	Fast page		
	MC-424000AC72	60 70 80	1630 1480 1270					
	MC-424000FB72*	60 70	1990 1810	19	3.3±0.3	Hyper page (EDO)		
	MC-424000FC72	60 70	1630 1450					
	MC-424000LAB72	60 70 80	1810 1630 1450	Fast page				
	MC-424000LAC72	70 80	1270 1090		Hyper page (EDO)			
	MC-424000LFB72*	60 70	1810 1630	Fast page				
	MC-424000LFC72	60 70	1450 1270					

★: Under development

Dynamic RAM Module

■ Synchronous DRAM DIMM

Organization (words ∞ bits)	Part number	Minimum cycle time MAX. (ns)	Refresh cycle (cycles/ ms)	Maximum supply current		Supply voltage (V)	Package	Remarks		
				Active (mA)	Standby (mA)					
2M ∞ 72	MC-452AA72	10 12 13	2K/32	765 720 675	18	3.3±0.3	• 200-pin DIMM Socket type (Gold plated)	Unbuffered		
	MC-452BA72	10 12 13		TBD	TBD			Buffered		
2M ∞ 80	MC-452AA80	10 12 13		850 800 750	20			Unbuffered		
	MC-454BA80	10 12 13		TBD	TBD			Buffered		
4M ∞ 72	MC-454BA/BC72	10 12 13								
4M ∞ 80	MC-454BA/BC80	10 12 13								

Static RAM

■ Low Power Static RAM

Capacity (bits)	Organization (words ∞ bits)	Part number	Access time MAX. (ns)	Maximum supply current			Supply voltage (V)	Package	Remarks	
				Active (mA)	Standby (mA)	Data retention (μA)				
256K	32K ∞ 8	μPD43256B with CS, OE	70	45	0.1	50	5±10 %	<ul style="list-style-type: none"> • 28-pin DIP (600 mil) • 28-pin SOP (450 mil) • 32-pin TSOP I (600 mil) • 28-pin TSOP I (8 ∞ 13.4 mm) 	L version	
			85	45	0.05	20			LL version	
		μPD43257B with CE1, CE2	70	45	0.1	50			<ul style="list-style-type: none"> • 28-pin DIP (600 mil) • 28-pin SOP (450 mil) 	L version
			85	45	0.05	20				LL version
1M	128K ∞ 8	μPD431000A with CE1, CE2, OE	70	70	0.1	50	<ul style="list-style-type: none"> • 32-pin DIP (600 mil) • 32-pin SOP (525 mil) • 32-pin TSOP I (8 ∞ 20 mm) 	L version		
			85		0.05	20		LL version		
			100							

■ Low Power Static RAM Low Voltage (2.7 to 5.5 V) Operation

Capacity (bits)	Organization (words ∞ bits)	Part number	Access time MAX. (ns)	Maximum supply current			Supply voltage (V)	Package
				Active (mA)	Standby (μA)	Data retention (μA)		
256K	32K ∞ 8	μPD43256B-B12 with CS, OE	120	20	25	20	3±10 %	<ul style="list-style-type: none"> • 28-pin SOP (450 mil) • 32-pin TSOP I (600 mil) • 28-pin TSOP I (8 ∞ 13.4 mm)
			85	45	50	20	3.3 < V _{CC} < 4.5	
				5±10 %				
1M	128K ∞ 8	μPD431000A-B15 with CE1, CE2, OE	150	20	25	20	3±10 %	<ul style="list-style-type: none"> • 32-pin SOP (525 mil) • 32-pin TSOP I (8 ∞ 20 mm)
			100	70	50	20	3.3 < V _{CC} < 4.5	
				5±10 %				

■ Low Power Static RAM Low Voltage (3.0 to 5.5 V) Operation

Capacity (bits)	Organization (words ∞ bits)	Part number	Access time MAX. (ns)	Maximum supply current			Supply voltage (V)	Package
				Active (mA)	Standby (mA)	Data retention (μA)		
256K	32K ∞ 8	μPD43256B-A10	100	45	50	20	3.3 ± 0.3 V	<ul style="list-style-type: none"> • 28-pin SOP (450 mil) • 32-pin TSOP I (600 mil) • 28-pin TSOP I (8 ∞ 13.4 mm)
			85				5±10 %	
		μPD43256B-A12	120				3.3 ± 0.3 V	
			85				5±10 %	

Static RAM

■ **Fast Static RAM**

Capacity (bits)	Organization (words ∞ bits)	Part number	Access time MAX. (ns)	Maximum supply current			Supply voltage (V)	Package	Remarks
				Active (mA)	Standby (mA)	Data retention (μA)			
1M	128K ∞ 8	μPD431008	15 17 20	160 150 140	10	-	5±10 %	• 32-pin SOJ (400 mil)	-
	128K ∞ 9	μPD431009	15 17 20	160 150 140				• 36-pin SOJ (400 mil)	
	64K ∞ 16	μPD431016	15 17 20	240 230 220				• 44-pin SOJ (400 mil)	
	64K ∞ 18	μPD431018	15 17 20	240 230 220					
4M	1M ∞ 4	μPD434004	20 25	150 140				• 32-pin SOJ (400 mil)	
	512K ∞ 8	μPD434008	20 25	190 170				• 36-pin SOJ (400 mil)	

■ **Fast Static RAM Low Voltage (3.0 to 3.6 V) Operation**

Capacity (bits)	Organization (words ∞ bits)	Part number	Access time MAX. (ns)	Maximum supply current			Supply voltage (V)	Package	
				Active (mA)	Standby (mA)	Data retention (μA)			
1M	128K ∞ 8	μPD431008L	17	120	100	5	-	3.3±0.3	• 32-pin SOJ (400 mil)
	128K ∞ 9	μPD431009L	20						• 36-pin SOJ (400 mil)
	64K ∞ 16	μPD431016L							• 44-pin SOJ (400 mil)
	64K ∞ 18	μPD431018L							

■ **Synchronous Static RAM**

Capacity (bits)	Organization (words ∞ bits)	Part number	Access time MAX. (ns)	Maximum supply current			Supply voltage (V)	Package	Remarks
				Active (mA)	Standby (mA)	Data retention (μA)			
1M	32K ∞ 32	μPD431232L	8 9 12	250	2	-	3.3±0.2	• 100-pin TQFP	-

Static RAM

■ BiCMOS Fast Static RAM

Capacity (bits)	Organization (words ∞ bits)	Part number	Access time MAX. (ns)	Maximum supply current			Supply voltage (V)	Package	Remarks
				Active (mA)	Standby (mA)	Data retention (μA)			
256K	32K ∞ 8	μPD46258	6 7	–	–	–	5±10 %	• 32-pin SOJ (300 mil)	–
1M	128K ∞ 8	μPD461008	8 9 10	185				• 32-pin SOJ (400 mil)	

■ BiCMOS Fast Static RAM (3.3 V ± 0.3 V)

Capacity (bits)	Organization (words ∞ bits)	Part number	Access time MAX. (ns)	Maximum supply current			Supply voltage (V)	Package	Remarks
				Active (mA)	Standby (mA)	Data retention (μA)			
256K	32K ∞ 8	μPD46259L	12	130	20	–	3.3±0.3	• 32-pin SOJ (300 mil)	–
1M	64K ∞ 16	μPD461016L	10 12	260	70		3.3 ^{+0.3} _{-0.15}	• 44-pin SOJ (400 mil)	
	64K ∞ 18	μPD461018L	10 12	260			3.3±0.3	• 44-pin TSOP II (400 mil)	

■ BiCMOS Synchronous Static RAM

Capacity (bits)	Organization (words ∞ bits)	Part number	Access time MAX. (ns)	Maximum supply current			Supply voltage (V)	Package	Remarks
				Active (mA)	Standby (mA)	Data retention (μA)			
1M	32K ∞ 18	μPD461318*	2	TBD	TBD	–	3.3±0.3	• 119-pin BGA	User-option ① Dual-CLK R/L ② Single-CLK R/R
			2.5						
			3						
			7						
			8.5						
			10						
			2						
			2.5						
			3						
			7						
8.5									
10									
32K ∞ 36	μPD461336*	2	TBD	TBD	–	3.3±0.3	• 119-pin BGA	User-option ① Dual-CLK R/L ② Single-CLK R/R	
		2.5							
		3							
		7							
		8.5							
		10							
		2							
		2.5							
		3							
		7							
8.5									
10									

* : Under development

Mask ROM

■ Mask ROM

Capacity (bits)	Organization (words ∞ bits)	Part number	Access time MAX. (ns)	Maximum supply current		Supply voltage (V)	Package	Remarks
				Active (mA)	Standby (mA)			
32M	2M ∞ 16 or 1M ∞ 32 (selectable)	μ PD23C32140*	100/30	120	0.1	5 ±10 %	<ul style="list-style-type: none"> 70-pin SSOP (500 mil) 70-pin TSOP II (400 mil) 	with page access read mode
	4M ∞ 8 or 2M ∞ 16 (selectable)	μ PD23C32000	120	70	<ul style="list-style-type: none"> 44-pin SOP (600 mil) 48-pin TSOP I (12 ∞ 18 mm)* 44-pin TSOP II (400 mil)* 		–	
16M	2M ∞ 8 or 1M ∞ 16 (selectable)	μ PD23C16000W	120	70	<ul style="list-style-type: none"> 42-pin DIP (600 mil) 44-pin SOP (600 mil) 48-pin TSOP I (12 ∞ 18 mm) 44-pin TSOP II (400 mil) 		μ PD16040A ...	with page access read mode
		μ PD23C16040A	120/35	100			Pin-compatible with PROM μ PD27C8000	
8M	1M ∞ 8 or 512K ∞ 16 (selectable)	μ PD23C8000W	120	70	<ul style="list-style-type: none"> 32-pin DIP (600 mil) 32-pin SOP (525 mil) 		Pin-compatible with PROM μ PD27C8001	
	1M ∞ 8	μ PD23C8001EJ	120	50				
4M	512K ∞ 8 or 256K ∞ 16 (selectable)	μ PD23C4000S μ PD23C4040	100 10/50	100 150	<ul style="list-style-type: none"> 40-pin DIP (600 mil) 40-pin SOP (525 mil) 		Pin-compatible with PROM μ PD27C4000 μ PD23C4040 ...	with page access read mode
	512K ∞ 8	μ PD23C4001EJ	120	50			<ul style="list-style-type: none"> 32-pin DIP (600 mil) 32-pin SOP (525 mil) 40-pin TSOP I (10 ∞ 20 mm) 	Pin-compatible with PROM μ PD27C4001
2M	256K ∞ 8	μ PD23C2001E	200	40	<ul style="list-style-type: none"> 32-pin DIP (600 mil) 		Pin-compatible with PROM μ PD27C2001	
1M	128K ∞ 8	μ PD23C1001EA	150	40			Pin-compatible with PROM μ PD27C1001A	
		μ PD23C1000EB			Pin-compatible with PROM μ PD27C1000A			
		μ PD23C1000B			–			
		μ PD23C1010B			–			

* : Under development

■ Mask ROM (Low Voltage Operation)

Capacity (bits)	Organization (words ∞ bits)	Part number	Access time MAX. (ns)	Maximum supply current		Supply voltage (V)	Package	Remarks
				Active (mA)	Standby (mA)			
32M*	4M ∞ 8 or 2M ∞ 16 (selectable)	μ PD23C32000	200	20	20	3.0±0.3	<ul style="list-style-type: none"> 44-pin SOP (600 mil) 48-pin TSOP I (12 ∞ 18 mm) 44-pin TSOP II (400 mil) 	–
16M	2M ∞ 8 or 1M ∞ 16 (selectable)	μ PD23C16000LW	200	20	20		<ul style="list-style-type: none"> 42-pin DIP (600 mil) 44-pin SOP (600 mil) 48-pin TSOP I (12 ∞ 18 mm) 44-pin TSOP II (400 mil) 	
8M	1M ∞ 8 or 512K ∞ 16 (selectable)	μ PD23C8000LW	230	30	30			

* : Under development

PROM

■ UV EPROM

Capacity (bits)	Organization (words ∞ bits)	Part number	Access time MAX. (ns)	Maximum supply current		Supply voltage (V)	Package	Remarks
				Active (mA)	Standby (mA)			
8M	1M ∞ 8 or 512K ∞ 16 (selectable)	μ PD27C8000	120 150 170	50	0.1	V _{PP} = 12.5±0.3 V _{CC} = 5 ±10 %	• 42-pin DIP (600 mil)	Pin-compatible with Mask ROM μ PD23C8000 series
	1M ∞ 8	μ PD27C8001	120 150 170	30			• 32-pin DIP (600 mil)	Pin-compatible with Mask ROM μ PD23C8001E series
4M	512K ∞ 8 or 256K ∞ 16 (selectable)	μ PD27C4000	150 170 200	50			• 40-pin DIP (600 mil)	Pin-compatible with Mask ROM μ PD23C4000 series
	256K ∞ 16	μ PD27C240	100 120 150					–
	512K ∞ 8	μ PD27C4001	120 [★] 150 170 200	30			• 32-pin DIP (600 mil)	Pin-compatible with Mask ROM μ PD23C4001E series
		μ PD27C040	100 120 150	50				
2M	256K ∞ 8	μ PD27C020	120 150	30			Pin-compatible with Mask ROM μ PD23C2001E series	
1M	128K ∞ 8	μ PD27C010A	100 120 150				Pin-compatible with Mask ROM μ PD23C1001E series	
	64K ∞ 16	μ PD27C210A	120 150	50		• 40-pin DIP (600 mil)	Pin-compatible with Mask ROM μ PD23C1024E series	

★: Under development

■ ONE TIME PROM

Capacity (bits)	Organization (words ∞ bits)	Part number	Access time MAX. (ns)	Maximum supply current		Supply voltage (V)	Package	Remarks
				Active (mA)	Standby (mA)			
8M	1M ∞ 8 or 512K ∞ 16 (selectable)	μ PD27C8000	150 170	50	0.1	V _{PP} = 12.5±0.3 V _{CC} = 5 ±10 %	• 42-pin DIP (600 mil) • 44-pin SOP (600 mil) • 48-pin TSOP I (12 ∞ 18 mm)	Pin-compatible with Mask ROM μ PD23C8000 series
	1M ∞ 8	μ PD27C8001	150 170	30			• 32-pin DIP (600 mil) • 32-pin SOP (525 mil)	Pin-compatible with Mask ROM μ PD23C8001E series
4M	512K ∞ 8 or 256K ∞ 16 (selectable)	μ PD27C4000	150 170 200	50			• 40-pin DIP (600 mil) • 40-pin SOP (525 mil)	Pin-compatible with Mask ROM μ PD23C4000 series
	512K ∞ 8	μ PD27C4001	120 [★] 150 170 200	30			• 32-pin DIP (600 mil) • 32-pin SOP (525 mil) • 40-pin TSOP I (10 ∞ 20 mm)	Pin-compatible with Mask ROM μ PD23C4001E series

★: Under development

PROM**■ EEPROM**

Capacity (bits)	Organization (words ∞ bits)	Part number	Access time MAX. (ns)	Maximum supply current		Supply voltage (V)	Package	Remarks
				Active (mA)	Standby (mA)			
256K	32K ∞ 8	μ PD28C256	200 250	50	0.1	5 ±10 %	• 28-pin DIP (600 mil)	–
64K	8K ∞ 8	μ PD28C64A	150 200				• 28-pin DIP (600 mil) • 28-pin SOP (450 mil) • 32-pin TSOP I (600 mil)	

■ SERIAL EEPROM

Capacity (bits)	Organization (words ∞ bits)	Part number	Serial interface	Active current (mA)	Standby current (mA)	Supply voltage (V)	Package
2K	256 ∞ 8	μ PD6252	CE, CS, SCL, SDA (2-wire BUS)	1.5	0.02	5 V ±10 %	• 8-pin DIP (300 mil) • 8-pin SOP (300 mil)
1K	128 ∞ 8	μ PD6253					
4K	512 ∞ 8	μ PD6254					
2K	256 ∞ 8	μ PD6272	CE, CS, I ² C BUS				
1K	128 ∞ 8	μ PD6273					
4K	512 ∞ 8	μ PD6274					
2K	256 ∞ 8	μ PD6255	CS, SCL, SDA (2-wire BUS)	1.0	0.005	1.8 to 3.5 V	
4K	512 ∞ 8	μ PD6257	CS, SCK, SI, SO (3-wire BUS)	1.5	0.003	5 V ±10 %	
8K	1024 ∞ 8	μ PD6258					

Flash MEMORY**■ Flash MEMORY**

Capacity (bits)	Organization (words ∞ bits)	Part number	Access time MAX. (ns)	Maximum supply current		Supply voltage (V)	Package	Remarks
				Active (mA)	Standby (mA)			
1M	128K ∞ 8	μ PD28F001	80 100 120	50	0.1	V _{PP} = 12±0.6 V _{CC} = 5 ±10 %	• 32-pin SOP (525 mil) • 32-pin TSOP I (8 ∞ 20 mm) • 32-pin QFJ	–

Other

■ Dual-Port Graphic Buffer

Capacity (bits)	Organization (words ∞ bits)	Part number	Random access time MAX. (ns)	Serial read cycle time (ns)	Maximum supply current		Supply voltage (V)	Package	Remarks
					Active (mA)	Standby (mA)			
4M	256K ∞ 16	μPD482444	60	20	130	10	5±10 %	• 64-pin SSOP (525 mil)	2WE Byte Control Fast Page Flash/Block Write Split Buffer Stopping Column
			70	22	110				
		80	25	90					
		μPD482445	60	20	130			• 64-pin SSOP (525 mil) • 70-pin TSOP II (400 mil)	2WE Byte Control Hyper Page Flash/Block Write Split Buffer Stopping Column
		μPD482445L	70	22	110	7	3.3±0.3		
2M	256K ∞ 8	μPD482234	60	20	155	10	5±10 %	• 40-pin SOJ • 44-pin TSOP II	Fast page Flash write Block write Split buffer
			70	22	195				
			80	25	190				
		μPD482235	60	20	155				Hyper page Flash write Block write Split buffer
			70	22	195				
			80	25	190				

■ Synchronous Graphics RAM

Capacity (bits)	Organization	Part number	Cycle time MIN. (ns)	Refresh cycle (cycles/ms)	Maximum supply current (mA)			Interface	Supply voltage (V)	Package	Function
					Active Normal/Burst (Grade-10, C.L=3)	Standby power down mode	Self refresh				
8M	128K ∞ 2 banks ∞ 32 bits	μPD481850	10 (100 MHz) 12 (83 MHz) 15 (66 MHz)	1024/16	105/365 90/310 85/285	3	2	LVTTTL	3.3±0.3	• 100-pin QFP (14 ∞ 20 mm)	Synchronous Interface Write-per-bit (Old Mask) 8 column Block Write

■ Graphic Memory

Capacity (bits)	Organization (words ∞ bits)	Part number	Random access time MAX. (ns)	Page mode access time MAX. (ns)	Maximum supply current		Supply voltage (V)	Package	Remarks
					Active (mA)	Standby (mA)			
4M	256K ∞ 16	μPD481440	70 80	35 40	180 165	2	5±10 %	• 40-pin SOJ (400 mil)	2WE Byte Control Flash write Block write

Other

■ Silicon File

Capacity (bits)	Organization (words ∞ bits)	Part number	Random access time MAX. (ns)	Page mode access time MAX. (ns)	Maximum supply current		Supply voltage (V)	Package
					Active (mA)	Self refresh (μA)		
16M	16M ∞ 1	μPD426171	60 70 80	40 45 50	100 90 80	Ta=0 to 55 °C: 30 (-L) Ta=0 to 55 °C: 50	3.3±0.3	<ul style="list-style-type: none"> • 26-pin SOJ (300 mil) • 26-pin TSOP II (300 mil)
	4M ∞ 4	μPD426174	60 70 80	40 45 50	100 90 80			
4M	4M ∞ 1	μPD42641	80	20	90	Ta=0-70°C: 240 Ta=0-60°C: 120 Ta=0-50°C: 60	5±10 %	<ul style="list-style-type: none"> • 26-pin SOJ • 26-pin TSOP II
	1M ∞ 4	μPD42644						
	4M ∞ 1	μPD42641-L						
	1M ∞ 4	μPD42644-L						

■ Field/Line Buffer

Capacity (bits)	Organization (words ∞ bits)	Part number	Read/Write cycle time MIN. (ns)	Data hold period (ms)	Maximum supply current active (mA)	Supply voltage (V)	Package	Remarks	
2M	256 ∞ 8	μPD42280	30/30 40/40 60/60	-	90 75 60	5±10 %	<ul style="list-style-type: none"> • 28-pin SOP • 28-pin ZIP 	Field buffer FIFO structure	
80K	10096 ∞ 8 5048 ∞ 16	μPD485506	25/25 27/27 35/35		140		<ul style="list-style-type: none"> • 44-pin TSOP II 	FAX, PPC Line buffer FIFO structure	
40K	5048 ∞ 8	μPD485505	25/25 27/27 35/35		90		<ul style="list-style-type: none"> • 24-pin SOP 		
7K	910 ∞ 8	μPD42101	34/34 34/69 69/69		1		70 60 35	<ul style="list-style-type: none"> • 24-pin DIP • 24-pin SOP 	NTSC Line buffer FIFO structure
9K	1135 ∞ 8	μPD42102	25/25 28/28 28/56 56/56				80 80 70 40		PAL Line buffer FIFO structure

Semi-Custom IC

Gate Array	84
• CMOS Gate Array	84
• BiCMOS Gate Array	89
• ECL Gate Array	90
UNIVERSAL PCI.....	90
MV Series	91
Cell Based IC	92
Analog Master	94

Gate Array

CMOS Gate Array

■ CMOS-6 family (channelless type)

Type number		μ PD65658	μ PD65664	μ PD65672	μ PD65676
Inte- gration	Internal gates	42240	72576	119232	177408
	Usable gate number	31680	54432	89424	133056
	Pad number *	236	304	384	464
Delay time	Internal gate	0.5 ns (fan-outs: 2, wiring length: 2 mm)/0.4 ns (power gate, fan-outs: 2, wiring length: 2 mm)			
	Input buffer	1.0 ns			
	Output buffer	2.0 ns (CL = 15 pF)			
Output drive capability		I _{OL} = 4.5, 9.0, 13.5, 18.0, 24.0 mA			
Supply voltage		5 V			

*: V_{DD}, GND terminals included. Number of pin which can be actually used depends on package.

■ CMOS-6A family (channelless type)

Type number		μ PD65630	μ PD65636	μ PD65640	μ PD65646	μ PD65650	μ PD65654	μ PD65656	μ PD65662
Inte- gration	Internal gates	5376	8000	11520	16240	21120	30720	40480	70272
	Usable gate number	3225	4800	6912	9744	12672	18432	24288	42163
	Pad number *	100	116	136	156	176	208	220	288
Delay time	Internal gate	0.5 ns (fan-outs: 2, wiring length: 2 mm)/0.4 ns (power gate, fan-outs: 2, wiring length: 2 mm)							
	Input buffer	1.0 ns							
	Output buffer	2.0 ns (CL = 15 pF)							
Output drive capability		I _{OL} = 4.5, 9.0, 13.5, 18.0, 24.0 mA							
Supply voltage		5 V							

*: V_{DD}, GND terminals included. Number of pin which can be actually used depends on package.

■ CMOS-6V family (channelless type) (1/2)

Type number		μ PD65631	μ PD65641	μ PD65644	μ PD65647
Inte- gration	Internal gates	5544	11520	14040	16240
	Usable gate number	3326	6912	8424	9744
	Pad number *	156	176	176	176
Delay time	Internal gate	0.5 ns (fan-outs: 2, wiring length: 2 mm)/0.4 ns (power gate, fan-outs: 2, wiring length: 2 mm)			
	Input buffer	1.0 ns			
	Output buffer	2.0 ns (CL = 15 pF)			
Output drive capability		I _{OL} = 4.5, 9.0, 13.5, 18.0, 24.0 mA			
Supply voltage		5 V			

*: V_{DD}, GND terminals included. Number of pin which can be actually used depends on package.

■ CMOS-6V family (channelless type) (2/2)

Type number		μ PD65648	μ PD65651	μ PD65652	μ PD65655
Inte- gration	Internal gates	18600	21120	26640	30720
	Usable gate number	11160	12672	15984	18432
	Pad number *	176	236	236	236
Delay time	Internal gate	0.5 ns (fan-outs: 2, wiring length: 2 mm)/0.4 ns (power gate, fan-outs: 2, wiring length: 2 mm)			
	Input buffer	1.0 ns			
	Output buffer	2.0 ns (CL = 15 pF)			
Output drive capability		I _{OL} = 4.5, 9.0, 13.5, 18.0, 24.0 mA			
Supply voltage		5 V			

*: V_{DD}, GND terminals included. Number of pin which can be actually used depends on package.

Gate Array

CMOS Gate Array

■ CMOS-6X family (channelless type)

Type number		μ PD65612	μ PD65622	μ PD65626	μ PD65632
Inte- gration	Internal gates	2244	4260	5760	8148
	Usable gate number	1346	2556	3456	4888
	Pad number *	80	100	120	120
Delay time	Internal gate	0.5 ns (fan-outs: 2, wiring length: 2 mm)/0.4 ns (power gate, fan-outs: 2, wiring length: 2 mm)			
	Input buffer	1.0 ns			
	Output buffer	2.0 ns (CL = 15 pF)			
Output drive capability		IOL = 4.5, 9.0, 13.5, 18.0, 24.0 mA			
Supply voltage		5 V			

*: V_{DD}, GND terminals included. Number of pin which can be actually used depends on package.

■ CMOS-8 family (channelless type) 2-Metal-layer (1/2)

Type number		μ PD65800	μ PD65801	μ PD65802	μ PD65803
Inte- gration	Internal gates	11712	21504	32000	42688
	Usable gate number	7027	12902	19200	25612
	Pad number *	172	228	268	308
Delay time	Internal gate	0.34 ns (fan-outs: 2, wiring length: 2 mm)/0.29 ns (power gate, fan-outs: 2, wiring length: 2 mm)			
	Input buffer	0.44 ns			
	Output buffer	1.6 ns (CL = 15 pF)			
Output drive capability		IOL = 3, 6, 9, 12, 18, 24 mA			
Supply voltage		5 V			

*: V_{DD}, GND terminals included. Number of pin which can be actually used depends on package.

■ CMOS-8 family (channelless type) 3-Metal-layer (2/2)

Type number		μ PD65804	μ PD65806	μ PD65808	μ PD65810	μ PD65811	μ PD65812	μ PD65813
Inte- gration	Internal gates	42688	58752	82432	103680	138776	176720	233280
	Usable gate number	32016	44064	61824	77760	104082	132540	174960
	Pad number *	308	340	404	452	524	588	676
Delay time	Internal gate	0.34 ns (fan-outs: 2, wiring length: 2 mm)/0.29 ns (power gate, fan-outs: 2, wiring length: 2 mm)						
	Input buffer	0.44 ns						
	Output buffer	1.6 ns (CL = 15 pF)						
Output drive capability		IOL = 3, 6, 9, 12, 18, 24 mA						
Supply voltage		5 V						

*: V_{DD}, GND terminals included. Number of pin which can be actually used depends on package.

■ CMOS-8L family (channelless type) 2-Metal-layer (1/3)

Type number		μ PD65840	μ PD65841	μ PD65842	μ PD65843	μ PD65845
Inte- gration	Internal gates	10912	20832	30192	40592	52528
	Usable gate number	6547	12499	18115	24355	31516
	Pad number *	164	204	212	244	276
Delay time	Internal gate	0.13 ns (fan-outs: 1, wiring length: 0 mm), 0.33 ns (fan-outs: 2, wiring length: 2 mm)/ 0.21 ns (power gate, fan-outs: 2, wiring length: 2 mm)				
	Input buffer	0.40 ns				
	Output buffer	1.67 ns (FO01, CL = 15 pF)				
Output drive capability		IOL = 3, 6, 9, 12, 18, 24 mA				
Supply voltage		3.3 V \pm 0.3 V				

*: V_{DD}, GND terminals included. Number of pin which can be actually used depends on package.

Gate Array

CMOS Gate Array

■ CMOS-8L family (channelless type) 2-Metal-layer (2/3)

Type number		μ PD65846	μ PD65848	μ PD65849	μ PD65850	μ PD65851
Integration	Internal gates	61904	81984	102272	120768	148256
	Usable gate number	37142	49190	61363	72460	88953
	Pad number *	300	340	380	412	452
Delay time	Internal gate	0.13 ns (fan-outs: 1, wiring length: 0 mm), 0.33 ns (fan-outs: 2, wiring length: 2 mm)/ 0.21 ns (power gate, fan-outs: 2, wiring length: 2 mm)				
	Input buffer	0.40 ns				
	Output buffer	1.67 ns (FO01, CL = 15 pF)				
Output drive capability		IOL = 3, 6, 9, 12, 18, 24 mA				
Supply voltage		3.3 V \pm 0.3 V				

*: V_{DD}, GND terminals included. Number of pin which can be actually used depends on package.

■ CMOS-8L family (channelless type) 2-Metal-layer (3/3)

Type number		μ PD65852	μ PD65853	μ PD65855	μ PD65858	μ PD65859
Integration	Internal gates	202752	255744	342000	488720	627328
	Usable gate number	121651	153446	205200	293232	376396
	Pad number *	524	588	676	804	908
Delay time	Internal gate	0.13 ns (fan-outs: 1, wiring length: 0 mm), 0.33 ns (fan-outs: 2, wiring length: 2 mm)/ 0.21 ns (power gate, fan-outs: 2, wiring length: 2 mm)				
	Input buffer	0.40 ns				
	Output buffer	1.67 ns (FO01, CL = 15 pF)				
Output drive capability		IOL = 3, 6, 9, 12, 18, 24 mA				
Supply voltage		3.3 V \pm 0.3 V				

*: V_{DD}, GND terminals included. Number of pin which can be actually used depends on package.

■ CMOS-8L family (channelless type) 3-Metal-layer (1/3)

Type number		μ PD65860	μ PD65861	μ PD65862	μ PD65863	μ PD65865
Integration	Internal gates	10912	20832	30192	40592	52528
	Usable gate number	8184	15624	22644	30444	39396
	Pad number *	164	204	212	244	276
Delay time	Internal gate	0.13 ns (fan-outs: 1, wiring length: 0 mm), 0.33 ns (fan-outs: 2, wiring length: 2 mm)/ 0.21 ns (power gate, fan-outs: 2, wiring length: 2 mm)				
	Input buffer	0.40 ns				
	Output buffer	1.67 ns (FO01, CL = 15 pF)				
Output drive capability		IOL = 3, 6, 9, 12, 18, 24 mA				
Supply voltage		3.3 V \pm 0.3 V				

*: V_{DD}, GND terminals included. Number of pin which can be actually used depends on package.

■ CMOS-8L family (channelless type) 3-Metal-layer (2/3)

Type number		μ PD65866	μ PD65868	μ PD65869	μ PD65870	μ PD65871
Integration	Internal gates	61904	81984	102272	120768	148256
	Usable gate number	46428	61488	76704	90576	111192
	Pad number *	300	340	380	412	452
Delay time	Internal gate	0.13 ns (fan-outs: 1, wiring length: 0 mm), 0.33 ns (fan-outs: 2, wiring length: 2 mm)/ 0.21 ns (power gate, fan-outs: 2, wiring length: 2 mm)				
	Input buffer	0.40 ns				
	Output buffer	1.67 ns (FO01, CL = 15 pF)				
Output drive capability		IOL = 3, 6, 9, 12, 18, 24 mA				
Supply voltage		3.3 V \pm 0.3 V				

*: V_{DD}, GND terminals included. Number of pin which can be actually used depends on package.

Gate Array

CMOS Gate Array**■ CMOS-8L family (channelless type) 3-Metal-layer (3/3)**

Type number	μ PD65872	μ PD65873	μ PD65875	μ PD65878	μ PD65879	
Inte- gration	Internal gates	202752	255744	342000	488720	627328
	Usable gate number	152064	191808	256500	366540	470496
	Pad number *	524	588	676	804	908
Delay time	Internal gate	0.13 ns (fan-outs: 1, wiring length: 0 mm), 0.33 ns (fan-outs: 2, wiring length: 2 mm)/ 0.21 ns (power gate, fan-outs: 2, wiring length: 2 mm)				
	Input buffer	0.40 ns				
	Output buffer	1.67 ns (FO01, CL = 15 pF)				
Output drive capability	IO _L = 3, 6, 9, 12, 18, 24 mA					
Supply voltage	3.3 V \pm 0.3 V					

*: V_{DD}, GND terminals included. Number of pin which can be actually used depends on package.

■ CMOS-8LCX family (channelless type) 3-Metal-layer (1/2)

Type number	μ PD65823	μ PD65825	μ PD65826	μ PD65828	μ PD65830	
Inte- gration	Internal gates	39856	50880	60320	80400	103360
	Usable gate number	29892	38160	45240	60300	77520
	Pad number *	284	316	340	388	436
Delay time	Internal gate	0.21 ns (fan-outs: 1, wiring length: 0 mm), 0.40 ns (fan-outs: 2, wiring length: 2 mm)/ 0.30 ns (power gate, fan-outs: 2, wiring length: 2 mm)				
	Input buffer	-				
	Output buffer	-				
Output drive capability	IO _L = 1, 2, 3, 6, 9, 12, 18, 24 mA					
Supply voltage	3.3 V \pm 0.3 V					

*: V_{DD}, GND terminals included. Number of pin which can be actually used depends on package.

■ CMOS-8LCX family (channelless type) 3-Metal-layer (2/2)

Type number	μ PD65831	μ PD65832	μ PD65833	μ PD65835	μ PD65838	
Inte- gration	Internal gates	153264	200120	255360	347200	486048
	Usable gate number	114948	150090	191520	260400	364536
	Pad number *	524	596	668	772	908
Delay time	Internal gate	0.21 ns (fan-outs: 1, wiring length: 0 mm), 0.40 ns (fan-outs: 2, wiring length: 2 mm)/ 0.30 ns (power gate, fan-outs: 2, wiring length: 2 mm)				
	Input buffer	-				
	Output buffer	-				
Output drive capability	IO _L = 1, 2, 3, 6, 9, 12, 18, 24 mA					
Supply voltage	3.3 V \pm 0.3 V					

*: V_{DD}, GND terminals included. Number of pin which can be actually used depends on package.

Gate Array

CMOS Gate Array

■ CMOS-9 family (1/2)

[2-Metal-layer]

Type number		μ PD65906	μ PD65907	μ PD65908	μ PD65909	μ PD65910
Integration	Internal gates *1	190152	249948	317904	376740	462088
	Usable gate counts *2	76060	99979	127161	150696	184835
Delay time	Internal gates	138 ps (2-input NAND, fan-out = 1, standard wiring length)				
	Input buffer *3	188 ps				
	Output buffer *4	874 ps				
Output drive capacity		IoL = 1, 2, 3, 6, 9, 12, 18, 24 mA				
Supply voltage		3.3 V \pm 0.3 V				

- *1: 1 gate = 2-input NAND gate. *2: usable gate: 40%
 *3: fanout = 2, wiring length = 2 mm *4: CL = 15pF, IoL = 18 mA

■ CMOS-9 family (2/2)

[2-Metal-layer]

Type number		μ PD65911	μ PD65913	μ PD65915	μ PD65917	μ PD65919
Integration	Internal gates *1	629824	805580	1076032	1545240	1990600
	Usable gate counts *2	251929	322232	430412	618096	796240
Delay time	Internal gates	138 ps (2-input NAND, fan-out = 1, standard wiring length)				
	Input buffer *3	188 ps				
	Output buffer *4	874 ps				
Output drive capacity		IoL = 1, 2, 3, 6, 9, 12, 18, 24 mA				
Supply voltage		3.3 V \pm 0.3 V				

- *1: 1 gate = 2-input NAND gate. *2: usable gate: 40%
 *3: fanout = 2, wiring length = 2 mm *4: CL = 15pF, IoL = 18 mA

■ CMOS-9 family (1/2)

[3-Metal-layer]

Type number		μ PD65926	μ PD65927	μ PD65928	μ PD65929	μ PD65930
Integration	Internal gates *1	190152	249948	317904	376740	462088
	Usable gate counts *2	114091	149968	190742	226044	277252
Delay time	Internal gates	138 ps (2-input NAND, fan-out = 1, standard wiring length)				
	Input buffer *3	188 ps				
	Output buffer *4	874 ps				
Output drive capacity		IoL = 1, 2, 3, 6, 9, 12, 18, 24 mA				
Supply voltage		3.3 V \pm 0.3 V				

- *1: 1 gate = 2-input NAND gate. *2: usable gate: 60%
 *3: fanout = 2, wiring length = 2 mm *4: CL = 15pF, IoL = 18 mA

■ CMOS-9 family (2/2)

[3-Metal-layer]

Type number		μ PD65931	μ PD65933	μ PD65935	μ PD65937	μ PD65939
Integration	Internal gates *1	629824	805580	1076032	1545240	1990600
	Usable gate counts *2	377894	483348	645619	927144	1194360
Delay time	Internal gates	138 ps (2-input NAND, fan-out = 1, standard wiring length)				
	Input buffer *3	188 ps				
	Output buffer *4	874 ps				
Output drive capacity		IoL = 1, 2, 3, 6, 9, 12, 18, 24 mA				
Supply voltage		3.3 V \pm 0.3 V				

- *1: 1 gate = 2-input NAND gate. *2: usable gate: 60%
 *3: fanout = 2, wiring length = 2 mm *4: CL = 15pF, IoL = 18 mA

Gate Array

BiCMOS Gate Array■ **BiCMOS-5 family**

Type number		μ PD67021	μ PD67031	μ PD67050	μ PD67070	μ PD67101	μ PD67240
Inte- gration	Maximum Number	2208	3240	5320	7216	10152	24528
	Maximum number of input pins	80	96	124	148	176	272
	Maximum number of output pins	80	96	124	148	176	272
Delay time	Internal gate	0.4 ns (fan-outs: 2, wiring length: 2 mm)					
	Input buffer	0.9 ns (TTL)					
		3.3 ns (TTL/ECL)					
		2.5 ns (ECL)					
	Output buffer	2.3 ns (TTL)					
3.5 ns (TTL/ECL)							
Output drive capability		1.3 ns (ECL)					
Output drive capability		IOL = 24, 48, 72 mA					
Supply voltage		VCC = 5 V (CMOS/TTL) VEE = -5.2 V (ECL-10KH) -4.5 V (ECL-100K)					

■ **BiCMOS-8 family**

Type number		μ PD67804 (Logic Type)	μ PD67852 (ECL mounted)
Inte- gration	CMOS Internal gates	236 K	57 K
	CMOS Usable gate number	165 K	40 K
	ECL Internal gates	-	5.0 K
	ECL Usable gate number	-	2.5 K
	Signal pin number	320	156
Delay time	Internal CMOS gate	180 ps (fun-outs: 1, wiring length: 0 mm) 370 ps (fun-outs: 2, wiring length: 2 mm)	
	Internal ECL gate	-	130 ps (fun-outs: 0, wiring length: 0 mm)
	Input buffer	0.23 ns (ECL: fun-outs: 1, wiring length: 0 mm) 0.43 ns (LVTTTL: fun-outs: 1, wiring length: 0 mm) 1.17 ns (GTL: fun-outs: 1, wiring length: 0 mm)	
		1.37 ns (LVTTTL: CL = 15 pF) 0.98 ns (GTL: CL = 15 pF) 0.99 ns (Slew rate GTL: CL = 15 pF)	
Supply voltage	ECL-100K	VEE1 = -2.0 V \pm 5% VEE2 = -4.5 V \pm 0.3 V	
	ECL-10KH	VEE1 = -2.0 V \pm 5% VEE2 = -5.2 V \pm 5%	
	LV-TTL	VCC = 3.3 V \pm 5%	
	GTL	VCC = 3.3 V \pm 5%	

Gate Array

ECL Gate Array

■ ECL-4A family

Type number		μ PB63020	μ PB63040	μ PB63060	μ PB63080	μ PB63100
Integration	Internal gates	2400	4000	6000	8000	10000
	Maximum number of input pins	102	140	174	200	236
	Maximum number of output pins	58	84	90	108	120
Delay time	Internal gate	0.27 ns (fan-outs: 3, wiring length: 3 mm)				
	Input buffer	0.3 ns (fan-outs: 1, wiring length: 3 mm)				
		0.7 ns (TTL, fan-outs: 1, wiring length: 3 mm)				
	Output buffer	0.65 ns (ECL-100K, $C_L = 15$ pF), 0.63 ns (ECL-10K, $C_L = 15$ pF)				
2.5 ns (TTL, $C_L = 15$ pF)						
Supply voltage	-5.2 V (ECL-10KH)					
	-4.5 V (ECL-100K)					
	5 V (TTL)					

UNIVERSAL PCI

■ UNIVERSAL PCI series (2-Metal-layer)

Type A *1		μ PD66001	μ PD66002	μ PD66004	μ PD66006	μ PD66008	μ PD66010	μ PD66011	μ PD66012
Type B *2		μ PD66081	μ PD66082	μ PD66084	μ PD66086	μ PD66088	μ PD66090	μ PD66091	μ PD66092
Integration	Internal gates	23392	32640	46464	68208	87648	121684	155584	209712
	Usable gate number	14035	19584	27878	40925	52589	73008	93350	125827
	Pad number *3	268	308	356	420	468	524	588	676
Delay time	Internal gate	0.14 ns (fan-out: 1, wiring length: 0 mm), 0.29 ns (fan-out: 2, wiring length: 2 mm)/ 0.20 ns (power gate, fan-out: 2, wiring length: 2 mm)							
	Input buffer	0.86 ns (3.3 V), 0.34 ns (5 V)							
	Output buffer	1.61 ns (3.3 V, $C_L = 15$ pF), 1.34 ns (5 V, $C_L = 15$ pF)							
Output drive capability		$I_{OL} = 3, 6, 9, 12, 18, 24$ mA							
Supply voltage		5 V $\pm 5\%$, 3.3 V ± 0.3 V							

*1: 5 V, 3.3 V, universal power supply interface

*2: 5 V, universal power supply interface

*3: V_{DD} , GND terminals included. Number of pin which can be actually used depends on package.

■ UNIVERSAL PCI series (3-Metal-layer)

Type A *1		μ PD66024	μ PD66026	μ PD66028	μ PD66030	μ PD66031	μ PD66032
Type B *2		μ PD66104	μ PD66106	μ PD66108	μ PD66110	μ PD66111	μ PD66112
Integration	Internal gates	46464	68208	87648	121684	155584	209712
	Usable gate number	34848	51156	65736	91260	116688	157284
	Pad number *3	356	420	468	524	588	676
Delay time	Internal gate	0.14 ns (fan-out: 1, wiring length: 0 mm), 0.29 ns (fan-out: 2, wiring length: 2 mm)/ 0.20 ns (power gate, fan-out: 2, wiring length: 2 mm)					
	Input buffer	0.86 ns (3.3 V), 0.34 ns (5 V)					
	Output buffer	1.61 ns (3.3 V, $C_L = 15$ pF), 1.34 ns (5 V, $C_L = 15$ pF)					
Output drive capability		$I_{OL} = 3, 6, 9, 12, 18, 24$ mA					
Supply voltage		5 V $\pm 5\%$, 3.3 V ± 0.3 V					

*1: 5 V, 3.3 V, universal power supply interface

*2: 5 V, universal power supply interface

*3: V_{DD} , GND terminals included. Number of pin which can be actually used depends on package.

MV Series

■ MV series (1/2)

[2-Metal-layer]

Type number		μ PD66041	μ PD66042	μ PD66044	μ PD66046	μ PD66048	μ PD66050	μ PD66051	μ PD66052
Integration	Internal gates *1	23392	32640	46464	68208	87648	121648	155584	209712
	Usable gate counts *2	14035	19584	27878	40925	52589	73000	93350	125827
	Pad number *3	268	308	356	420	468	524	588	676
Delay time	Internal gates	0.14 ns (fan-outs = 1, wiring length = 0 mm) 0.29 ns (fan-outs = 2, wiring length = 2 mm) 0.20 ns (fan-outs = 2, wiring length = 2 mm) (power gate)							
	Input buffer *4	0.86 ns (3.3 V), 0.34 ns (5 V)							
	Output buffer *5	1.61 ns (3.3 V), 1.34 ns (5 V)							
Output drive capacity		IOL = 3, 6, 9, 12, 18, 24 mA							
Supply voltage		5 V \pm 5%, 3.3 V \pm 0.3 V							

*1: 1 gate = 2-input NAND gate. *2: usable gate: 60%

*3: VDD, GND terminals included. Number of pin which can be actually used depends on package.

*4: fanout = 2, wiring length = 2 mm *5: CL = 15pF

■ MV series (2/2)

[3-Metal-layer]

Type number		μ PD66064	μ PD66066	μ PD66068	μ PD66070	μ PD66071	μ PD66072
Integration	Internal gates *1	46464	68208	87648	121684	155584	209712
	Usable gate counts *2	34848	51156	65736	91263	116688	157284
	Pad number *3	356	420	468	524	588	676
Delay time	Internal gates	0.14 ns (fan-outs = 1, wiring length = 0 mm) 0.29 ns (fan-outs = 2, wiring length = 2 mm) 0.20 ns (fan-outs = 2, wiring length = 2 mm) (power gate)					
	Input buffer *4	0.86 ns (3.3 V), 0.34 ns (5 V)					
	Output buffer *5	1.61 ns (3.3 V), 1.34 ns (5 V)					
Output drive capacity		IOL = 3, 6, 9, 12, 18, 24 mA					
Supply voltage		5 V \pm 5%, 3.3 V \pm 0.3 V					

*1: 1 gate = 2-input NAND gate. *2: usable gate: 75%

*3: VDD, GND terminals included. Number of pin which can be actually used depends on package.

*4: fanout = 2, wiring length = 2 mm *5: CL = 15pF

Cell Based IC

■ **CB-C7 family**

- CPU core and memory macro are mounted on high integration IC achieved by the advanced 0.8 μm processing technology.
- Three different types of user logic block; TAT intended type (FT type) and high integration intended type (HD type and VX type).

Type number		μPD93XXX	μPD94XXX	μPD951XX	μPD961XX	
Integration *		120 K gate (max.) (2-layer wiring) / 180 K gate (max.) (3-layer wiring) / 270 K gate (max.) (VX, 3-layer wiring)				
Maximum number of input/output signal lines		440				
Delay time	Internal gate	0.18 ns (@5 V) / 0.43 ns (@3 V) (fan-outs: 1, wiring length: 0 mm), 0.44 ns (@5 V) / 0.90 ns (@3 V) (fan-outs: 2, wiring length: 2 mm)				
	Power gate	0.33 ns (@5 V) / 0.67 ns (@3 V) (fan-outs: 2, wiring length: 2 mm)				
	Input buffer	0.60 ns (@5 V) / 0.76 ns (@3 V) (fan-outs: 2, wiring length: 2 mm)				
	Output buffer	1.6 ns (@5 V, 8 mA buffer) / 3.2 ns (@3 V, 4.4 mA buffer) (C _L = 15 pF)				
Library	Input/output buffer	Same as NEC's Gate Array and Interface block with test mode, oscillator block				
	Function block	Same as NEC's Gate Array				
	Macro	CPU	-		V20HL, V30HL, Z80, etc.	
		Peripheral devices	-		μPD71037/5X, FDC, etc.	
		Memory	RAM	RAM, ROM	RAM	RAM, ROM
Analog		A/D Converter, D/A Converter, etc. (Under development)				
Power consumption		6.5 μW/MHz/Cell (@5 V) / 2.6 μW/MHz/Cell (@3 V)				
Output drive capability		I _{OL} = 4, 8, 12, 24, 48 mA (@5 V) / I _{OL} = 2.2, 4.4, 6.6 mA (@3 V)				
Interface level		CMOS, TTL compatible / 3 V Interface				
Process		0.8 μm rule CMOS process, aluminum 2-layer/3-layer wiring				

*: When not mounting hard macro

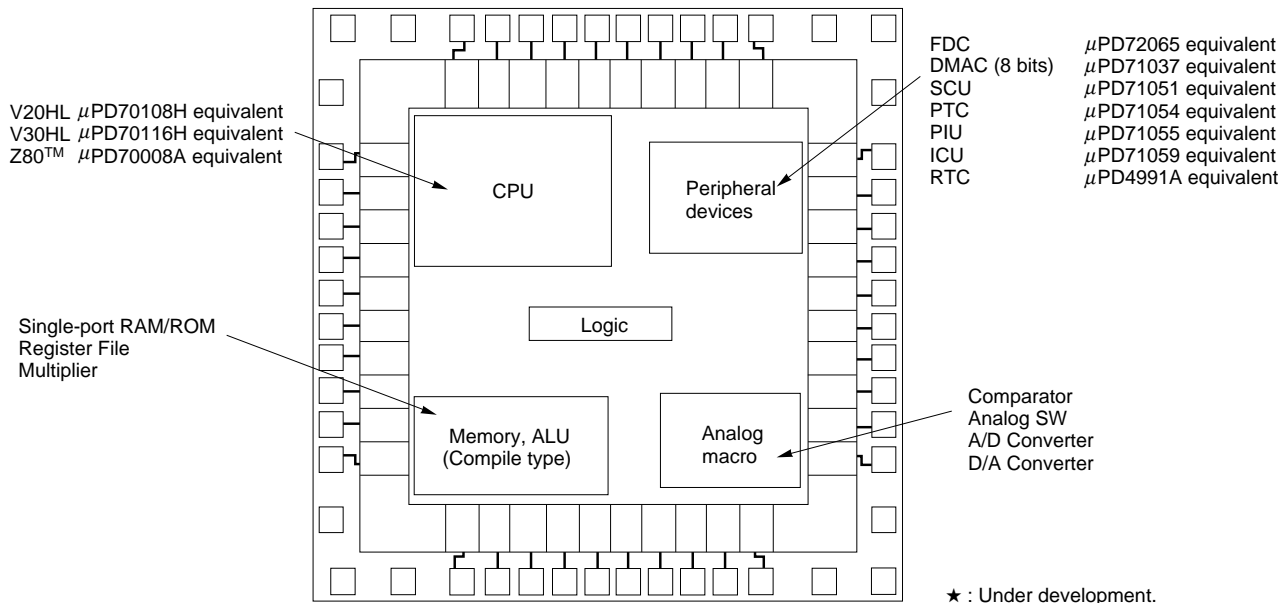

Cell Based IC

■ CB-C8 family

- High integration and high speed IC achieved by the most advanced 0.5 μm processing technology.
- Low power consumption (power supply: 3.3 V \pm 0.3 V)
- Lower power type of Y-block is available.

Type number		$\mu\text{PD93600}$	$\mu\text{PD94600}$	$\mu\text{PD95600}$	$\mu\text{PD96600}$		
Integration *		400 K gate (MAX.) (2-layer wiring) 600 K gate (MAX.) (3-layer wiring)					
Maximum number of input/output signal lines		880					
Delay time	Internal gate	0.13 ns (fan-outs: 1, wiring length: 0 mm) 0.29 ns (fan-outs: 2, wiring length: 2 mm)					
	Power gate	0.22 ns (fan-outs: 2, wiring length: 2 mm)					
	Input buffer	0.36 ns (fan-outs: 2, wiring length: 2 mm)					
	Output buffer	1.46 ns (9 mA buffer) (CL = 15 pF)					
Library	Input/output buffer	Input buffer: 3 V, 3.3 V, 5 V TTL-I/F buffer Output buffer: 3, 6, 9, 12, 18, 24, 48 mA (3.3 V, 3 V I/F) 1, 2, 3, 6, 9 mA (5 V I/F)					
	Macro	CPU	-		V30MX, Z80, etc.		
		Memory	RAM	ROM, RAM		RAM	ROM, RAM
		Peripheral	-	-		FDC, DMAC, 7105x, etc.	
		Analog	A/D Converter, D/A Converter (Under development)				
Power consumption		1.5 $\mu\text{W}/\text{MHz}/\text{Cell}$ (3.3 V), 1.1 $\mu\text{W}/\text{MHz}/\text{Cell}$ (Y-block, 3.3 V)					
Output drive capability		$I_{OL} = 1, 2, 3, 6, 9, 12, 18, 24$ mA					
Interface level		LV-TTL interface ($V_{IL} = 0.8$ V, $V_{IH} = 2.2$ V)					
Process		0.5 μm rule CMOS process, aluminum 2-layer/3-layer wiring					

*: When not mounting hard macro

Library

Macro	CPU	V30MX *1	$\mu\text{PD70008}$ *2
	Peripheral	FDC, DMAC, 7105x	
	Memory	ROM, RAM	
	Analog	A/D Converter, D/A Converter, Analog switch	
	Others	Register file	
Special block*		Scan, Rambus™, PLL, GTL, PCI	

*1: New developed original CPU core for CB-C8 family.
Software compatible with V20HL/V30HL CPU.

*2: Under development

*2: Compatible with Z80

Analog Master

The Analog Master is a semi-custom LSI for creating analog circuits on a master wafer by inter-connecting pre-defused elements (bipolar transistors, resistors, and capacitors, already formed on the wafer) with the user-defined wiring.

■ Feature

■ Very short development period

Four to eight weeks from layout design to ES (Engineering Sample) production

■ Suitable in case of small lot production

A few thousand LSIs per lot (six months) in case of simulation level interface (the number depends on product)

■ Powerful line-up

4 families (14 masters) are provided to cover wide range of operating frequency, withstand voltage, and number of elements used.

■ Various macro libraries

To reduce user's works, variety of macros are provided such as operational amplifier, comparator, regulator, etc.

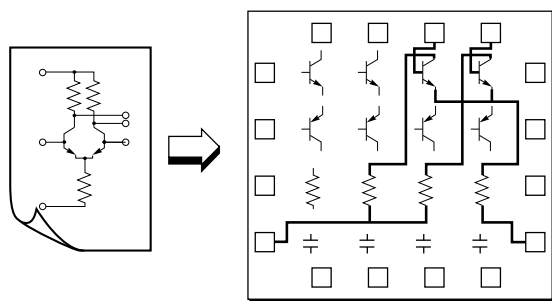

bipolar transistors, resistors, and capacitors, already formed on master wafer.

■ Product list

Item	Family name		CHS family			CHS-A family			V-CHS family	M-CHS family				
Process	High speed bipolar								Super high speed bipolar	High speed, high breakdown voltage bipolar				
Absolute maximum ratings	14 V								11 V	44 V				
Features	Allows high speed signal transaction of analog circuit								f ≤ 1 GHz	<ul style="list-style-type: none"> High breakdown voltage: V_{CCMax} = 44 V f ≤ Several MHz 				
	f ≤ Several ten of MHz													
Product name	μPC5020	μPC5021	μPC5022	μPC5023	μPC5024	μPC5031	μPC5032	μPC5034	μPC5102	μPC5200	μPC5201	μPC5202	μPC5203	μPC5204
Number of Pad	28	32	50	22	80	36	56	82	24	24	28	40	52	62
Total number of element	1628	2328	3042	727	6152	576	1472	2252	1367	658	1038	1799	3104	4578
NPN Transistor (Driver Transistor)	260	368	476	129	836	118 (13)	298 (18)	446 (26)	186	105	163	283	484	710
PNP Transistor	224	320	416	116	672	105	280	450	65	84	140	252	448	672
Resistors	1116	1600	2098	468	4560	338	854	1266	1090	456	712	1225	2108	3108
Capacitors	28	40	52	14	84	15	40	90	26	9	15	27	48	72
Micro library	Operational amplifier, Comparator, Regulator Filter, ECL, Switch, Timer, Super White TEG *					Super White TEG *, Another macro library is under development.			–	Operational amplifier, Comparator, Regulator, Switch				
Package	DIP, S-DIP, SOP, S-SOP, QFP, TQFP					S-DIP, SOP, S-SOP, QFP, TQFP			DIP, S-DIP, SOP	DIP, S-DIP, SOP, S-SOP, QFP, TQFP				

*: Super White TEG (Test Element Group) includes function macro libraries (regulator, operational amplifier, comparator, zero-cross-comparator, reset, driver, switch)

Particular Purpose IC

Speech Synthesis IC	96
DSP	97
Liner CCD Sensor	98
Communication IC	99
Mass Storage IC	105
Display IC	106
Motor Driver	109
Image IC	109
MPEG IC	109
Audio IC	110
TV IC	112
Digital Image IC	113
Multisync Monitor IC	114
On-Screen Character Display IC	115
VCR IC	116
Video Camera IC	117
Remote Control IC	117
Clock IC	118
Rotary Encoder IC	118
A/D Converter IC	118
D/A Converter IC	119
Line Driver Receiver IC	119
Vehicle Communication IC	120

Speech Synthesis IC

■ Fixed phrase play back

Item		Device	μ PD7755	μ PD7756A	μ PD7757	μ PD7758A	μ PD77P56	μ PD7759	
Synthesis method		ADPCM, PCM + waveform element							
Sampling frequency		5, 6, 8 kHz							
Speech data memory		96 Kbit mask ROM	256 Kbit mask ROM	512 Kbit mask ROM	1 Mbit mask ROM	256 Kbit one time PROM	1 Mbit external		
Synthesizing time	Speech* (ADPCM)	4 seconds typ.	12 seconds typ.	24 seconds typ.	50 seconds typ.	12 seconds typ.	50 seconds typ.		
	Melodies & sound effects (PCM+waveform element)	30 seconds typ.	85 seconds typ.	170 seconds typ.	340 seconds typ.	85 seconds typ.	340 seconds typ.		
Package		<ul style="list-style-type: none"> • 18-pin DIP (300 mil) • 24-pin SOP (375 mil, 450 mil) 					<ul style="list-style-type: none"> • 20-pin DIP (300 mil) • 24-pin SOP (450 mil) 		<ul style="list-style-type: none"> • 40-pin DIP • 52-pin QFP

*: The synthesis time for the speech is the value for a 6 kHz sampling.

■ Record/play back

		μ PD77501	
Speech coding method		ADPCM	
Sampling frequency		6 kHz	
Compressed speech data rate		2 bits (12 kbps), 3 bits (18 kbps), 4 bits (24 kbps)	
External memory type		DRAM area (4M bits ∞ 4 max.)	ROM/SRAM area (1M bits max.)
Applications		Message record/play back	Fixed phrase play back, response message record/play back
Record/play back time	12kbps	Approximately 23 minutes and 18 seconds	Approximately 1 minute and 27 seconds
	18kbps	Approximately 15 minutes and 30 seconds	Approximately 1 minute
	24kbps	Approximately 11 minutes and 30 seconds	Approximately 44 seconds
Internal functions		<ul style="list-style-type: none"> • DTMF receiver • Band-pass filter • Microphone amplifier (fixed/variable gain) 	<ul style="list-style-type: none"> • 10-bit over sampling A/D, D/A converters • ADPCM encoder/decoder • Host CPU interface
Supply voltage		4.75 to 5.25 V	
Supply current		35 mA typ. (6 mA max. during power down)	
Process		CMOS	
Package		• 80-pin QFP (0.65 mm pitch)	

		μ PD77502	
Speech coding method		FLC Method (Fixed point Low bit rate Coding) (FLC is a unique NEC method based on CELP) (CELP = Code Excited Linear Predictive coding)	
Sampling frequency		8 kHz	
Compressed speech data rate		4 kbps	
External memory type		DRAM area (4M bits ∞ 4 or 16M bits ∞ 1)	ROM (or SRAM) area (16M bits max.)
Applications		In Coming Message	Fixed. OGM *1, Users OGM *1
Record/play time length		60 minutes	60 minutes
Functions		<ul style="list-style-type: none"> • FLC Encoder/Decoder • Echo Canceller (For Full duplex speaker phone application) • DTMF/Sine Wave/etc, Generator 	<ul style="list-style-type: none"> • μ/A low PCM I/F • Host CPU I/F • Silence Compression
Supply voltage		5 V \pm 10%	
Supply current		120 mA (operate mode), 20 mA (power down mode)	
Process		CMOS	
Package		• 100-pin QFP (0.65 mm pitch)	

*1 : OGM: Out Going Message

DSP

	μ PD77C25	μ PD77C25-10	μ PD77220-10	μ PD77230A	μ PD77240
Instruction cycle (ns)	122	100	100	150	90
Data type *1	fixed		fixed	fixed/floating	fixed/floating
Multiplier precision (bits)	16 ∞ 16 \emptyset 31		24 ∞ 24 \emptyset 47	32 ∞ 32 \emptyset 55	32 ∞ 32 \emptyset 55
ALU precision (bit)	16		47	55	55
Internal memory (words ∞ bits)	Program ROM	2K ∞ 24	2K ∞ 32	2K ∞ 32	2K ∞ 32 *2
	Program RAM	–	–	–	–
	Data ROM	1K ∞ 16	1K ∞ 24	1K ∞ 32	1K ∞ 32 *2
	Data RAM	256 ∞ 16	512 ∞ 24	1K ∞ 32	1K ∞ 32
External memory (words x bits)	–		8K ∞ 24	8K ∞ 32	62K ∞ 32 (program) 16M ∞ 32 (data)
Package	<ul style="list-style-type: none"> • 28-pin DIP • 44-pin QFJ • 32-pin SOP 	<ul style="list-style-type: none"> • 28-pin DIP • 28-pin QFJ • 32-pin SOP 	<ul style="list-style-type: none"> • 68-pin PGA • 68-pin QFJ 	<ul style="list-style-type: none"> • 68-pin PGA 	<ul style="list-style-type: none"> • 132-pin PGA

*1: fixed: Fixed point decimal floating: Floating point decimal

*2: Internal library program

	μ PD77016	μ PD77017	μ PD77018	μ PD77015
Instruction cycle (ns)	30	30	30	30
Data type *1	fixed			
Multiplier precision (bits)	40 + 16 ∞ 16 \emptyset 40			
ALU precision (bit)	40			
Internal memory (words ∞ bits)	Program ROM	–	12K ∞ 32	24K ∞ 32
	Program RAM	1.5K ∞ 32	256 ∞ 32	256 ∞ 32
	Data ROM	–	8K ∞ 16	24K ∞ 16
	Data RAM	4K ∞ 16	4K ∞ 16	6K ∞ 16
External memory (words x bits)	48K ∞ 32 (program) 96K ∞ 16 (data)	32K ∞ 16 (data)	32K ∞ 16 (data)	32K ∞ 16 (data)
Package	• 160-pin QFP	• 100-pin TQFP	• 100-pin TQFP	• 100-pin TQFP

*1: fixed: Fixed point decimal floating: Floating point decimal

Liner CCD sensor

■ **Black-and-white**

Type number	Effective number of picture element (bit)	Sensitivity (TYP.) (V/Lx·s)	Data rate (MAX.) (MHz)	Package	Remarks
μ PD35H74	2592	5.4	10	• 22-pin DIP	High sensitivity 2.5K-bit sensor
μ PD35H71A	5000	5.2	40	• 22-pin DIP	High speed 5K-bit sensor
μ PD3594	2592	144	2	• 22-pin DIP	Built in timing gen., S/H, variable output Amp.
μ PD3732	1760	90	2	• 22-pin DIP	Built in S/H, output Amp.
μ PD3733	2088	90	2	• 22-pin DIP	Built in S/H, output Amp.
μ PD3734	2660	70	3	• 22-pin DIP	Built in S/H, output Amp.
μ PD3743	2088	90	2	• 22-pin DIP	Built in output Amp. CS output
μ PD3737	5150	7.5	20	• 22-pin DIP	
μ PD3753	2088	90	2	• 22-pin DIP	Single 5 V power supply Built in reset/clamp pulse gen.

■ **Color**

Type number	Effective number of picture element (bit)	Sensitivity (TYP.) (V/Lx·s)	Data rate (MAX.) (MHz)	Package
μ PD3725D-01	5000 ∞ 3	R 3.87 G 3.80 B 2.07	16	• 24-pin DIP
μ PD3726	3648 ∞ 3	R 1.50 G 1.52 B 0.84	8	• 22-pin DIP
μ PD3727	5300 ∞ 3	R 2.20 G 2.00 B 1.20	10	• 22-pin DIP
μ PD3723	G 2048 R, B 1024	R 9.2 G 7.5 B 3.8	1	• 22-pin DIP

Communication IC

■ Communication LSI

Type number	Function	Features	Package
μ PD72001-11	Multi-protocol serial controller	Allows communication in ASYNC, COP, and BOP mode (2 ch) μ PD72001-11: 5 V Operation μ PD72001-A8: 3.3 V Operation	<ul style="list-style-type: none"> • 40-pin DIP • 52-pin QFP • 52-pin QFJ • 44-pin TQFP
μ PD72001-A8			<ul style="list-style-type: none"> • 40-pin DIP • 52-pin QFJ • 52-pin QFP
μ PD72002-11	Multi-protocol serial controller	Allows communication in ASYNC, COP, and BOP mode (1 ch)	<ul style="list-style-type: none"> • 40-pin DIP • 44-pin QFP • 44-pin QFJ • 44-pin TQFP
μ PD72103	HDLC controller	HDLC frame control, link/separation are possible, internal DMA controller	<ul style="list-style-type: none"> • 64-pin SDIP • 68-pin QFJ • 80-pin QFP
μ PD72103A*		8 Mbps operation	
μ PD72105	LAN controller	Accommodates CSMA/ACK	<ul style="list-style-type: none"> • 48-pin DIP • 52-pin QFJ
μ PD72107	Packet communication control LSI (X.25 communication control)	Can accommodate high speed transmission (4 MHz) Conforms ITU-T recommendation X.25 (LAP-B '84 ver)	<ul style="list-style-type: none"> • 64-pin shrink DIP • 68-pin QFJ • 80-pin QFP
μ PD72305	LAP-D protocol processing LSI	Supports LAP-D protocol of ITU-T recommendation	<ul style="list-style-type: none"> • 64-pin shrink DIP • 68-pin QFJ • 80-pin QFP
μ PD98201	S interface transceiver for NT or TE	4-wire full duplexed communication (basic access) Conforms to ITU-T recommendation I430	<ul style="list-style-type: none"> • 64-pin QFP
μ PD98203	S interface transceiver for NT	Conforms to ITU-T recommendation I430	<ul style="list-style-type: none"> • 20-pin DIP
μ PD98204	ISDN rate adapter	RA + MPSC + HDLC on 1 chip small/thin package	<ul style="list-style-type: none"> • 80-pin TQFP
μ PD98205	ISDN basic rate interface controller	S-IFC + HDLC + V20HL + peripheral on 1 chip small/thin package	<ul style="list-style-type: none"> • 144-pin LQFP
μ PD9951	7 kHz-band linear codec	7 kHz-band 16-bit A/D, D/A	<ul style="list-style-type: none"> • 52-pin QFP
μ PD9952	SB-ADPCM codec	SB-ADPCM on 1 chip	<ul style="list-style-type: none"> • 32-pin SOP • 28-pin DIP
μ PD6316	D2B controller/driver	Conforms to D2B interface	<ul style="list-style-type: none"> • 16-pin DIP/SOP
μ PD6708	IE Bus™ controller/driver	Transmit data buffer: 4 bytes Receive data buffer: 20 bytes	<ul style="list-style-type: none"> • 16-pin SOP (300 mil)
μ PD72042A		Transmit data buffer: 33 bytes Receive data buffer: 40 bytes	<ul style="list-style-type: none"> • 16-pin SOP (375 mil)
μ PD72042B			
μ PC2590	IE Bus™ driver/receiver	Can connect to μ PD7809X	<ul style="list-style-type: none"> • 8-pin SOP

* : Under development

[ISDN Terminal Adapter]

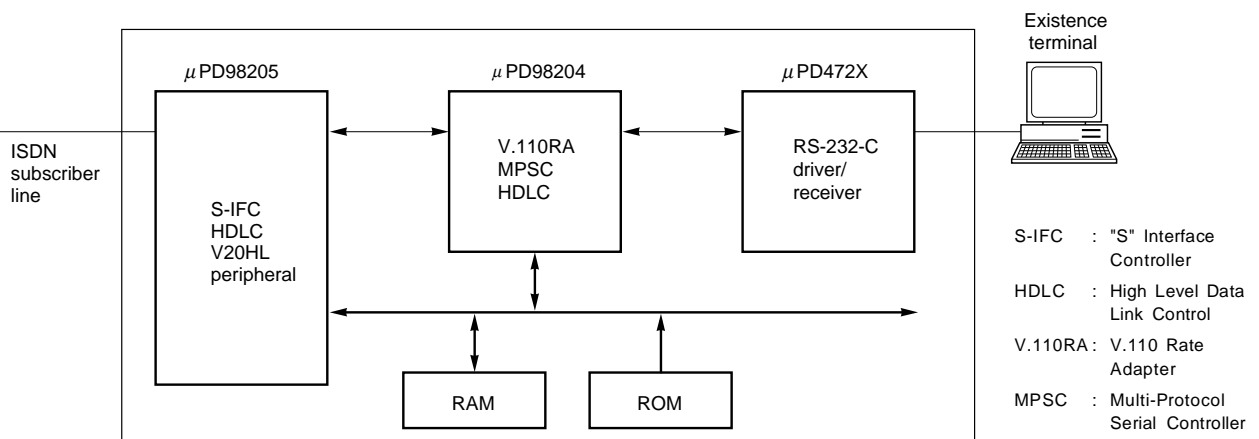

Communication IC

■ **Chip Set for ATM-LAN**

Type number	Function	Features	Package
μ PD98401A	Local ATM SAR chip	<ul style="list-style-type: none"> Comforms to ITU-TS, ANSI (T1S1) and ATM Forum Recommendations Implements the required AAL-5 SAR sublayer and ATM layer function 	<ul style="list-style-type: none"> 208-pin QFP (Fine Pitch)
μ PD98402A	Local ATM SONET Frammer	<ul style="list-style-type: none"> ATM physical layer having the TC sublayer function Comforms to ATM Forum UNI specifications SONET STS-3c frame format 	<ul style="list-style-type: none"> 160-pin QFP (Fine Pitch)

■ **Analog Line Card LSI**

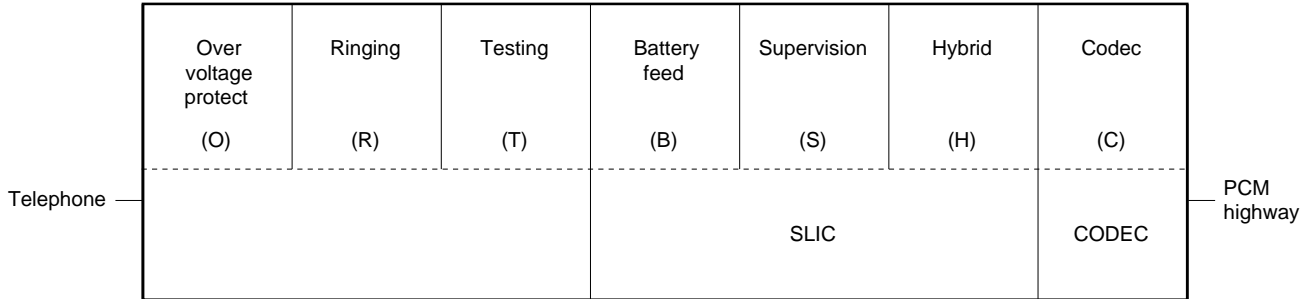

SLIC (BSH-LSI)

μ PC7151	Constant resistance feeding method (-48V)	• 32-pin QFJ
μ PC7063	Constant current feeding method (-24V)	
μ PC7161	Constant current feeding method (-48V)	

CODEC (PCM CODEC)

μ PD9604A	μ -law, internal PLL, DGS	• 16-pin DIP
μ PD9605A	A-law, internal PLL, DGS	
μ PD9621	A-law, internal PLL	• 16-pin DIP
μ PD9622	μ -law, internal PLL	• 18-pin QFJ
μ PD9624	μ -law, internal PLL, DGS	• 18-pin QFJ
μ PD9625	A-law, internal PLL, DGS	

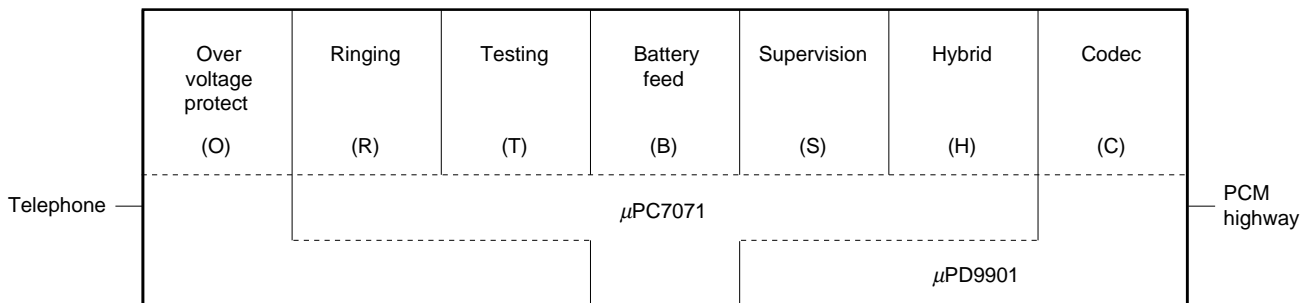

BS-SLIC

μ PC7071	<ul style="list-style-type: none"> Tip-Ring polarity reverse 3 relay drivers 	• 32-pin QFJ
--------------	--	--------------

Digital CODEC

μ PD9901	Terminal impedance and Hybrid balance network can be selected by combining μ PC7071	• 28-pin QFJ
--------------	---	--------------

Communication IC

■ **Telephone LSI**

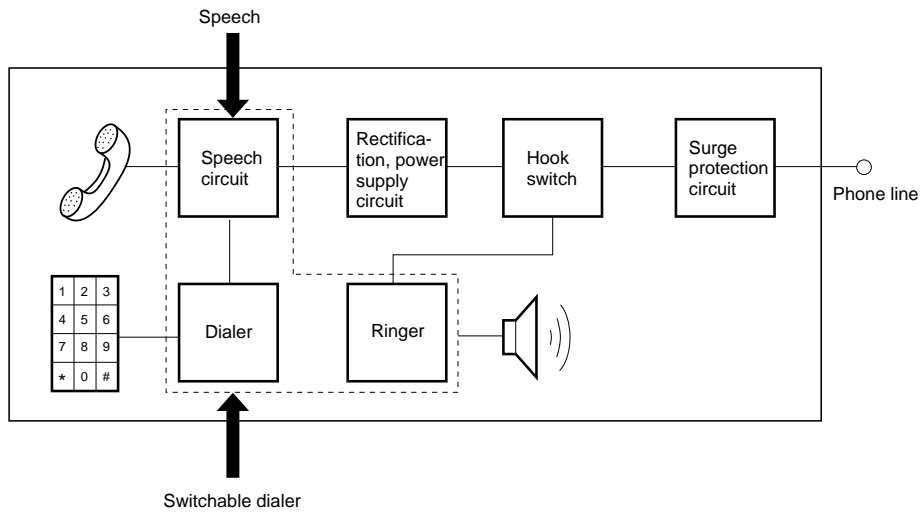

Speech	μPC7002	Auto/manual pad function Adjustable receiver gain, internal receiver amplifier	• 28-pin SDIP
--------	----------------	--	---------------

Communication IC

■ Digital Cordless Telephone (Hand Set) LSI

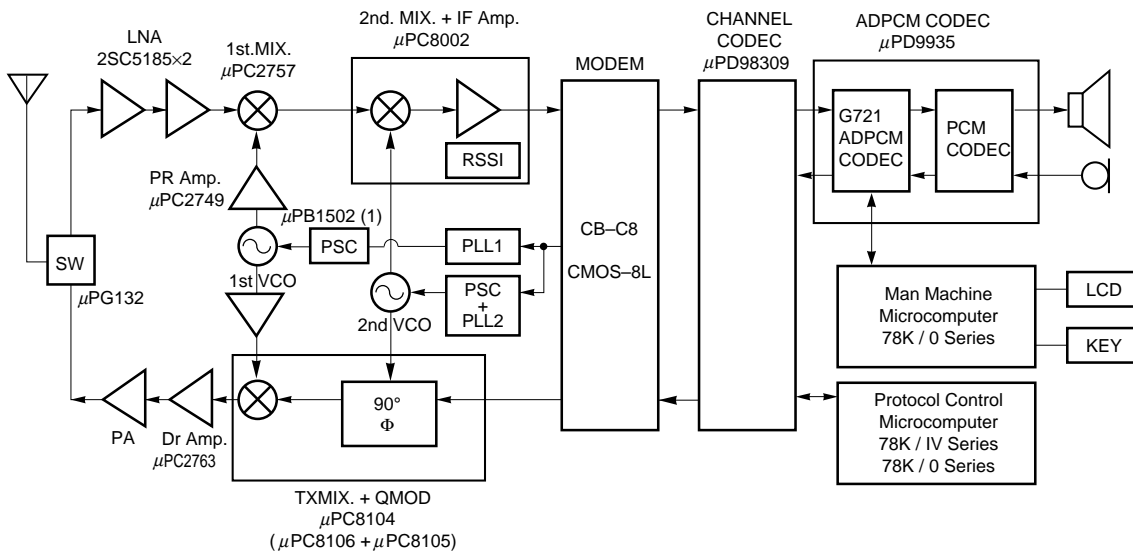

Type number	Function	Features	Package
μPG132	SW: Antena Switch (L-SPDT SW)	Low Power Loss: 0.6 dB (TYP.), @f = 2 GHz Hi speed switching time: 40 ns, 3 V operation	• 8-pin SSOP
2SC5185	LNA: Low Noise Transistor	NF: 1.3 dB (TYP.), @2V, 3 mA, f = 2 GHz fr: 13 GHz (TYP.), @2 V, 20 mA, f = 2GHz	• 4-pin super mini-mold
μPC2757	1st MIX.: L Band Down Converter	NF: 16 dB (TYP.), SSB mode, @frF = 2GHz, fIF = 250 MHz, Power Consumption: Vcc = 3 V, Icc = 5.6 mA	• 6-pin mini-mold
μPC2749	Pr Amp.: Low Noise Amp	NF: 4.0 dB (TYP.), @, f = 1.9 GHz, Vcc = 3 V GP: 16 dB (TYP.), @f = 1.9 GHz, Vcc = 3 V	• 6-pin mini-mold
μPC8002	2nd. MIX. + IF Amp.	Input Frequency Range: f _{MIX} = 250 MHz (TYP.) ~ 500 MHz (MAX.) Power Consumption: Vcc = 3 V, Icc = 3.4 mA	• 20-pin SSOP
μPB1502(1)	PSC: ~ 2 GHz Prescaler	Operation Frequency: ~ 2 GHz, Input Power Sensivity: 130 ~ 220 mVp-p, Power Consumption: Vcc = 3 V, Icc = 6.7 mA	• 8-pin SOP
μPC8104	TX MIX + QMOD: Up Converter + Quadrature Modulator	Operation Frequency Range: fr _{Fout} = 900 MHz ~ 2 GHz QMOD: f _{LoIn} = f _{MoDout} = 100 MHz ~ 400 MHz, @Vcc = 3 V	• 20-pin SSOP
μPC8105	400 MHz Quadrature Modulator For Digital Mobile Communication	Operation Frequency: f _{Lo} = 100 MHz ~ 400 MHz, f _{I/Q} = DC ~ 10 MHz Low Current Dissipation: 16 mA (TYP.)	• 16-pin SSOP
μPC8106	2.0 GHz Up Converter ICs For Cellular and Cordless Telephones	Operation Frequency Range: fr _{Fout} = 0.4 GHz ~ 2.0 GHz, f _{Fin} = 100 MHz ~ 400 MHz Low Current Dissipation: 9 mA	• 6-pin-mini-mold
μPC2763	Dr Amp.: Midium Power Amp.	Output Level Po (sat): +8.0 dBm, @f = 1.9 GHz, Vcc = 3 V NF: 5.5 dB (TYP.), @f = 1.9 GHz, Vcc = 3 V	• 6-pin mini-mold
μPD658XX	Modem: CMOS G/A	Supply Voltage: VDD = 3.3 V, 0.5 μm rule, 10 K ~ 627 K gate on Chip	(EX.) QFP (0.5P): 304pins, PGA: 528pins
μPD98309	Digital Cordless Telephone (PHS) Channel Codec	1 slot TDMA/TDD control conforming to RCRSTD-28 (for PS/CS), VDD = 2.7 ~ 3.3 V, IDD = 2 mA at 3 V	• 100-pin QFP
μPD9935	ADPCM Codec	Internal allowing operation with 8 kHz frame Low Power Consumption: VDD = 3 V, IDD = 7 mA	• 38-pin SSOP
78K/IV Series	Protocol Control 16-bit Single Chip Microcomputer	Supply Voltage Range: 2.7 V ~ 5.5 V, Memory Space: 1 M, Power Management Function	• 80-pin QFP
78K/0 Series	Protocol Control/Man Machine 8-bit Single Chip Microcomputer	Supply Voltage Range: VDD = 2 ~ 6 V, Low Power Consumption: VDD = 3 V, IDD = 0.8 mA	• 80-pin QFP • 80-pin WQFN

Communication IC

■ Analog Cellular Telephone IC

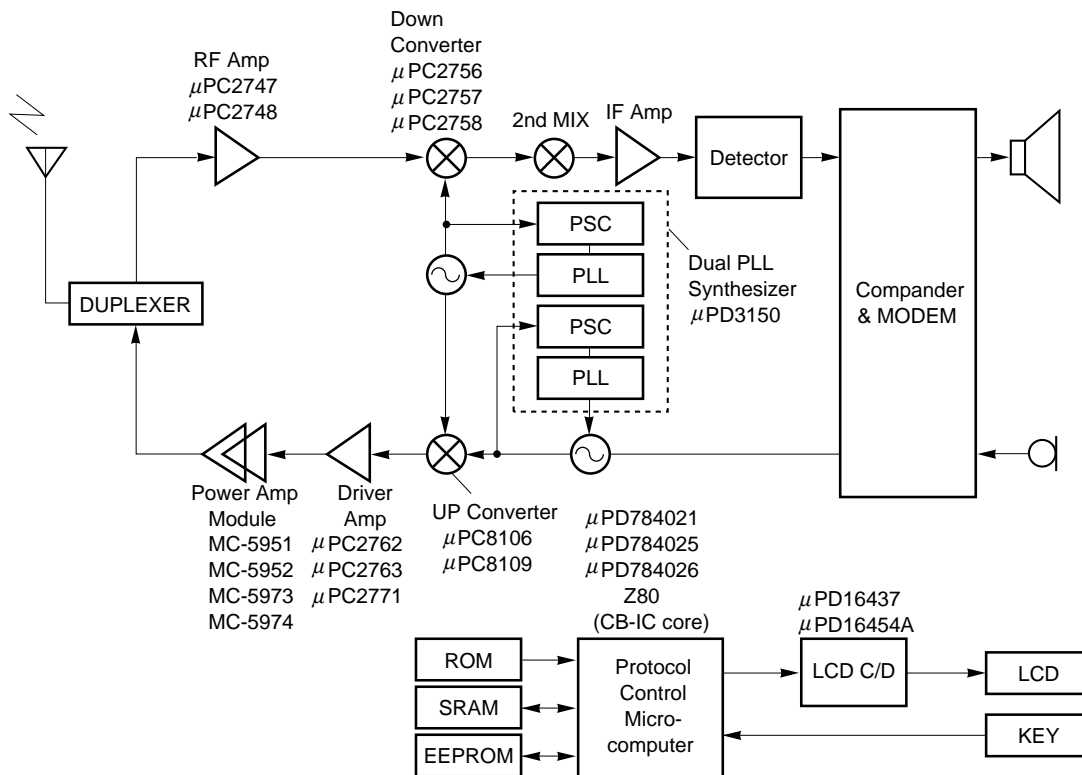

■ Digital Cellular Telephone IC

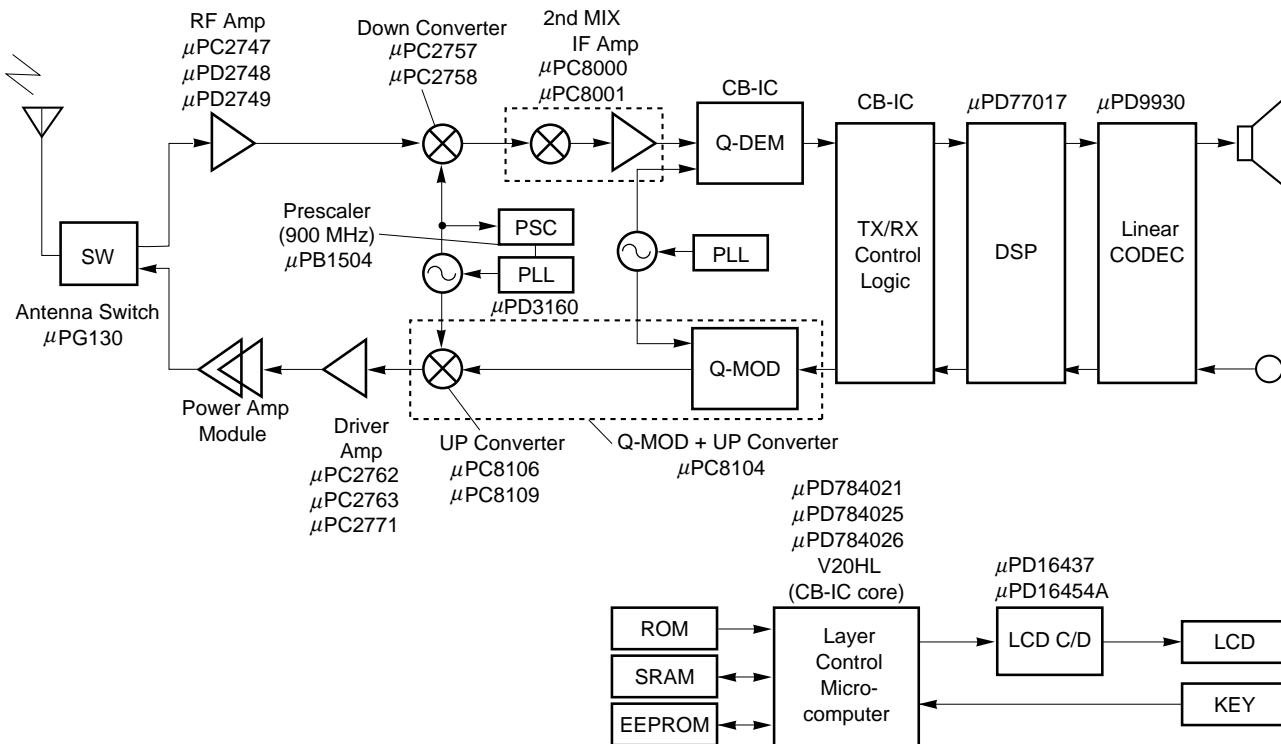

Communication IC

Type number	Function	Features	Package
MC-5951	GaAs Power Amp for AMPS	V _{DD} = 5.8 V P _{OUT} ≥ 30.5 dBm, G _P ≥ 24 dB	metal package 17 ∞ 12 ∞ 4 mm
MC-5952	GaAs Power Amp for E-TACS	V _{DD} = 5.8 V P _{OUT} ≥ 30.5 dBm, G _P ≥ 24 dB	
MC-5973	GaAs Power Amp for AMPS	V _{DD} = 4.6 V P _{OUT} ≥ 30.5 dBm, G _P ≥ 24 dB	
MC-5974	GaAs Power Amp for E-TACS	V _{DD} = 4.6 V P _{OUT} ≥ 30.5 dBm, G _P ≥ 24 dB	
μPG130	GaAs Antenna Switch (100 MHz ~ 2 GHz)	low power loss; 0.5 dB (at 1 GHz)	• 8-pin SOP/ SSOP
μPC2747	Low Noise RF Amp (900 MHz)	+3 V single power source, NF = 3.3 dB, f _u = 1.8 GHz	• 6-pin mini-mold
μPC2748		+3 V single power source, NF = 2.8 dB, high gain (19 dB)	
μPC2749	Low Noise RF Amp (2 GHz)	+3 V single power source, low power consumption (I _{CC} = 6 mA)	• 6-pin mini-mold
μPC2757	Down Converter (900 MHz ~ 2 GHz)	+3 V single power source, low power consumption	• 6-pin mini-mold
μPC2758		+3 V single power source, low distortion	
μPC8106	Up Converter (100 MHz ~ 2 GHz)	+2.7 ~ 5.5 V low distortion (IP ₃ = +4.5 dBm)	• 6-pin mini-mold
μPC8109		+2.7 ~ 5.5 V low power consumption (I _{CC} = 5 mA)	
μPC2771	Driver Amp (900 MHz ~ 1.5 GHz)	+3 V single power source, high output power (+12 dBm @ 900 MHz, +11 dBm @ 1.5 GHz)	• 6-pin mini-mold
μPC2762	Driver Amp (~ 2 GHz)	+3 V single power source, f _u = 2.9 GHz	• 6-pin mini-mold
μPC2763		+3 V single power source, high gain (20 dB)	
μPC8000	5 V 2nd Mixer + IF Amp (455 kHz)	+5 V single power source, high limiting sensitivity (−90 dBm) wide RSSI dynamic range (90 dB) linearity ≤ ±2dB	• 14-pin SSOP
μPC8001	3 V 2nd Mixer + IF Amp (455 kHz)	+3 V single power source, on-chip RSSI resistor high speed power on time (174 μs)	• 14-pin SSOP
μPC8104	Up Converter + Quadrature Modulator	+2.7 ~ 5.5 V single power source, high phase variation stability, wide output range (0.9 ~ 1.9 GHz)	• 20-pin SSOP
μPD3150	Dual PLL Synthesizer for Analog Cellular	+2.7 ~ 5.5 V power source, on-chip prescaler possible to switch lock sensitivity	• 20-pin SSOP
μPB1504	Prescaler (500 MHz ~ 1.1 GHz)	+3 V single power source high input sensitivity (−19 ~ +4 dBm) low power consumption (2.4 mA)	• 8-pin SOP
μPD77017	16-bit DSP	V _{DD} = 3 V high performance (33 MIPS) GUI-based high integrated development tools low power consumption	• 100-pin QFP
μPD9930	13-bit Linear CODEC	programmable tone generator (DTMF, GSM triple tone) mic./receiver Amp, GSM DAI	• 44-pin QFP
μPD784021 μPD784025 μPD784026	16-bit Single Chip Microcomputer	V _{DD} = 2.7 ~ 6.0 V, low power consumption, 1 M byte linear addressing on-chip timers, serial I/O, A/D, D/A, ROM, RAM	• 80-pin QFP
V20HL (CB-IC core)	16-bit Microprocessor	3 V operation 1 M byte memory space peripheral options (CB-IC macro) (timers, serial I/O, A/D, D/A, ROM, RAM etc.)	QFP etc.
Z80 (CB-IC core)	8-bit Microprocessor	3 V operation (full static) peripheral options (CB-IC macro) (timers, serial I/O, A/D, D/A, ROM, RAM etc.)	QFP etc.
μPD16454A	LCD Controller/Driver	on-chip DC/DC Converter (5 V ∅ 10 V), 24 ∞ 2	• TAB bare chip
μPD16437	3 V LCD Controller/Driver	on-chip DC/DC Converter (3 V ∅ 9 V, 5 V ∅ 10 V) 12 ∞ 2	• TAB bare chip

Mass Storage IC

Type number	Function	Features	Package
μPD72065B	Floppy disk controller	Low power consumption by CMOS	<ul style="list-style-type: none"> • 40-pin DIP • 52-pin QFP • 44-pin QFJ
μPD72068	Floppy disk controller	Internal VFO write compensation circuit Internal register for accommodating IBM-PC/AT	<ul style="list-style-type: none"> • 80-pin QFP • 84-pin QFJ
μPD72064	Floppy disk controller	Internal VFO for accommodating IBM-PC/AT	<ul style="list-style-type: none"> • 52-pin QFP • 44-pin QFJ
μPD72070	Floppy disk controller	Functional superset of μPD765A, supports 4MB, 16-byte FIFO in the data register	<ul style="list-style-type: none"> • 64-pin QFP
μPD72611	SCSI-2 controller	Conforms to ANSI ∞ 3T9.2/86-109 Rev. 10C High speed synchronous transfer 10 MBytes/s	<ul style="list-style-type: none"> • 100-pin QFP
μPD72050	MO (Magneto-Optical) disk controller	Support 3.5" (230 MB max), 5.25" (1.3 GB max) Embedded SCSI-2 controller/driver Buffer memory control up to 4 MB	<ul style="list-style-type: none"> • 160-pin QFP
μPD6378A	CD ROM decoder LSI	Conforms to CD-ROM XA format Supports CD triple-speed playback	<ul style="list-style-type: none"> • 100-pin QFP
μPD63701	CD ROM decoder LSI	Supports 512K bytes of external DRAM	<ul style="list-style-type: none"> • 100-pin QFP
μPD63721	1 chip CD-ROM controller	Digital Servo, Data Processor, CD-ROM Decoder, Host I/F on 1 chip Supports Quadruple speed operation, ATAPI Include automatic adjust servo function Wide capture range Internal Digital Attenuator Supports PIO mode 3, DMA mode 1 Internal Buffer Memory Controller (128K word ∞ 4 bi-512K word ∞ 8 bit DRAM/256K byte SRAM)	<ul style="list-style-type: none"> • 160-pin QFP
μPC2138	R/W amplifier for hard disk drive MIG Head	Low noise, low input capacitance, and high recording density	<ul style="list-style-type: none"> • 20-pin SSOP
μPC2132			
μPC2133	R/W amplifier for hard disk drive TF Head	Low noise, low input capacitance, and high recording density	<ul style="list-style-type: none"> • 20-pin SSOP
μPC2102	R/W amplifier for floppy disk controller	Low power Internal PLA, D/A	<ul style="list-style-type: none"> • 20-pin SSOP
μPD72051	PD controller	PCR format controller/Error Correction CD-ROM Decoder/Error Correction ATA-2 controller (Support ATAPI) Buffer Manager	<ul style="list-style-type: none"> • 144-pin QFP

Display IC

■ Fluorescence indicator panel (FIP) driver IC

Type number	Drives	Number of outputs	Withstand voltage (V)	Output current (mA)	Output type	Package	Main applications
μ PD6300	Static	20	40	5	Pch-O.D	• 28-pin DIP	Automotive (instrument panel)
μ PD6320 μ PD6321	Static	39	18	1	CMOS	• 52-pin QFP	Car stereo
μ PD6323B	Static	21	40	5	Pch-O.D	• 28-pin DIP	Automotive (instrument panel)
μ PD6340	Dynamic	20	80	25	NPN+Nch	• 52-pin QFP	ECR, PPC
μ PD6700	Static	47	18	1	CMOS	• 56-pin QFP	Car stereo
μ PD16304	Dynamic	40	200	20	CMOS	• 80-pin QFP*	Graphic FIP module
μ PD16306	Dynamic	64	80	50	CMOS	• 100-pin QFP	
μ PD16306A	Dynamic	64	80	25	CMOS	• 100-pin QFP	
μ PD16310	Dynamic	40	80	50	CMOS	• 80-pin QFP*	
μ PD16325*	Dynamic	40	150	150	CMOS	• 80-pin QFP*	
μ PD16326*	Dynamic	32	150	20	CMOS	• 44-pin QFP	

*: Three direction lead

★: Under development

■ Fluorescence indicator panel (FIP®) controller/driver IC

Type number	Drives	Duty (Max.)	Number of outputs		Number of characters*	Logic voltage (V)/ Drive voltage (V)	Package	Main application	Remarks
			Segments	Grids					
μ PD16311	Segment	1/16	12	16	192 segments	5/35	• 52-pin QFP	VCR	Included key scan
μ PD16312	Segment	1/11	11	11	121 segments	5/35	• 44-pin QFP	VCR	
μ PD16313	Segment	1/11	11	11	121 segments	5/35	• 44-pin QFP	VCR	Included key scan (μ PD16312 mirror)

*: At maximum duty

Display IC

■ Liquid crystal display (LCD) controller/driver IC

Type number	Drives	Duty (MAX.)	Number of outputs		Number of characters*1	Logic voltage (V)/ Drive voltage (V)	Package	Main application	Remarks
			Segments	Commons					
μ PD7225	Segment	1/4	32	4	128 segments	2.7 ~ 5.5/ 2.7 ~ 5.5	• 52-pin QFP • 56-pin QFP		
μ PD7227	DOT character	1/16	40	8	8 ∞ 1 characters	5/5	• 64-pin QFP		
μ PD7228	DOT character	1/16	42	16	8 ∞ 2 characters	5/5	• 80-pin QFP		
μ PD7228A	DOT character	1/16	42	16	8 ∞ 2 characters	5/12	• 80-pin QFP		
μ PD7229	DOT character	1/16	42	16	8 ∞ 2 characters	5/5	• 80-pin QFP		Custom ROM only
μ PD7229A	DOT character	1/16	42	16	8 ∞ 2 characters	5/12	• 80-pin QFP		Custom ROM only
μ PD16430A	Segment	1/4	60	4	240 segments	3.5 ~ 6/ 3.5 ~ 14	• 80-pin QFP	Car audio	
μ PD16431A	Segment	1/4	56	4	224 segments	2.7 ~ 5.5/ 2.7 ~ 6.5	• 80-pin QFP	Car audio	Included key scan
μ PD16432B*	DOT character	1/15	60/65	15/8	12 ∞ 2 characters + 60 pictographs	2.7 ~ 5.5/12	• 100-pin QFP	Car audio	Included key scan
μ PD16434	DOT character	1/16	42	16	8 ∞ 2 characters	2.7 ~ 5.5/12	• 80-pin QFP		
μ PD16435 μ PD16435A	Graphic	1/73	119	73	119 ∞ 71 dots + 119 ∞ 2 pictographs	2.7 ~ 5.5/10*2	• TCP	Mobile phone	Included DC/DC Converter
μ PD16437	DOT character	1/16	60	16	12 ∞ 2 characters + 60 ∞ 2 pictographs	3.0 ~ 5.5/10*2	• TCP	Mobile phone	Included DC/DC Converter
μ PD16437A*	DOT character	1/16	60	16	12 ∞ 2 characters + 60 ∞ 2 pictographs	2.7 ~ 5.5/10*2	• TCP	Mobile phone	Included DC/DC Converter
μ PD16454A	DOT character	1/14	120	14	24 ∞ 2 characters	5/10*2	• TCP	Mobile phone	Included DC/DC Converter
μ PD16670*	DOT character	1/33	60	33	12 ∞ 4 characters + 60 pictographs	2.7 ~ 3.6/12*2	• CHIP	Mobile phone	Included DC/DC Converter
μ PD16675*	Graphic	1/36	128	34	128 ∞ 32 dots + 128 ∞ 32 pictographs	2.7 ~ 5.5/10*2	• TCP	Pager	Included DC/DC Converter
μ PD16676* μ PD16676A*	Graphic	1/32	61	16	61 ∞ 16 dots	2.7 ~ 5.5/12	• TCP	Pager	-

*1 : At maximum duty

* : Under development

*2 : Internal DC/DC Converter

Display IC

■ Liquid crystal display (LCD) driver IC

Type number	Drives	Number of outputs	Withstand voltage (V)	Package	Main applications
μ PD6320 μ PD6321	Static	39	18	• 52-pin QFP	Car stereo
μ PD16443B	TFT (source) 8 gray scale	192	20	• TCP (slim type)	LCD module for OA
μ PD16444A	TFT (source) 8 gray scale	192	20	• TCP (slim type)	LCD module for OA
μ PD16445	TFT (source) 8 gray scale	192	20	• TCP (slim type)	LCD module for OA
μ PD16446	TFT (gate)	120	31	• TCP (slim type)	LCD-TV & for OA
μ PD16650*	TFT (gate)	120/128	40	• TCP (slim type)	LCD-TV & for OA
μ PD16405	TFT (source)	120	20	• TCP	LCD-TV
μ PD16447	TFT (source)	120	15	• TCP	LCD-TV for Automobile
μ PD16448*	TFT (source)	240	5	• TCP	LCD-TV
μ PD16406	TFT (source)	120	20	• TCP	LCD-HDTV
μ PD16407	TFT (source)	120	20	• TCP (slim type)	LCD-HDTV
μ PD16404	TFT (gate)	140	25	• TCP	LCD-TV
μ PD16429A	TFT (source) 8 gray scale	192	20	• TCP	EWS
μ PD16408	TFT (source) Analog	192	20	• TCP	EWS
μ PD16601*	TFT (source) Analog	192	15	• TCP (slim type)	EWS
μ PD16409A*	TFT (source) Analog	192	20	• TCP	VGA
μ PD16620*	TFT (source) 64 gray scale	240	5	• TCP (slim type)	For VGA standard (logic; 5 V)
μ PD16622	TFT (source) 64 gray scale	240	5	• TCP (slim type)	For VGA standard (logic; 5 V)
μ PD16623	TFT (source) 64 gray scale	240	5	• TCP (slim type)	For VGA standard (logic; 3.3 V)
μ PD16624	TFT (source) 64 gray scale	240	5	• TCP (slim type)	For SVGA standard (logic; 5 V)
μ PD16625	TFT (source) 64 gray scale	240	5	• TCP (slim type)	For SVGA standard (logic; 3.3 V)
μ PD16629*	TFT (source) 64 gray scale	240	5	• TCP (slim type)	For SVGA standard (logic; 3.3 V)
μ PD16630	TFT (source) 64 gray scale	240	15	• TCP (slim type)	For VGA/SVGA standard
μ PD16640*	TFT (source) 64 gray scale	300/309	5	• TCP (slim type)	For SVGA/XGA standard (drive; 3.3/5 V)
μ PD16641*	TFT (source) 64 gray scale	240	5	• TCP (slim type)	For VGA standard (drive; 3.3/5 V)
μ PD16661*	STN (column) 4 gray scale included RAM	160	5	• TCP	For PDA (1/8 VGA ~ VGA)
μ PD16666*	STN (row)	240	31	• TCP	For PDA (1/8 VGA ~ VGA)

* : Under development

■ Plasma display, EL display driver IC

Type number	Drives	Number of outputs	Withstand voltage (V)	Output current (mA)	Output type	Package
μ PD6337	AC-PDP row/column	32	200	300	Nch-O.D	• 52-pin QFP
μ PD16300	DC-PDP row	41	150	500	NPN-O.C	• 80-pin QFP*
μ PD16301	DC-PDP column	64	200	3	Pch-O.D	• 80-pin QFP
μ PD16302	EL column	40	250	100	CMOS	• 80-pin QFP*
μ PD16305	AC-PDP row	40	200	400	CMOS	• 80-pin QFP*
μ PD16306	AC-PDP/EL column	64	80	50	CMOS	• 100-pin QFP
μ PD16306A	AC-PDP/EL column	64	80	25	CMOS	• 100-pin QFP
μ PD16307	DC-PDP row	41	150	300	NPN-O.C	• 80-pin QFP*
μ PD16309	DC-PDP column	64	200	3	Pch-O.D	• 100-pin QFP
μ PD16325*	AC-PDP row	40	150	150	CMOS	• 80-pin QFP*
μ PD16327*	AC-PDP column	64	150	40	CMOS	• 100-pin QFP

* : Three direction lead

* : Under development

Display IC

Other driver IC

Type number	Number of outputs	Withstand voltage (V)	Output current (mA)	Output type	Package	Main applications
μ PD6320 μ PD6321	4 ∞ 4	18	20	NPN+Nch	• 52-pin QFP	Car stereo (LED)
μ PD6322	4 ∞ 6	7	20	NPN+Nch	• 20-pin DIP	Car stereo (LED)
μ PD6345	8	40	100	NPN-O.C	• 16-pin DIP • 16-pin SOP	Thermal head, LED, solenoid
μ PD16320A	48	20	130	Nch-O.D	• 80-pin QFP	Thermal head, LED
μ PD16322	32	250	50	Nch-O.D	• 52-pin QFP	Ink jet printer

Pch-O.D : P-ch open-drain output (source driver), Nch-O.D: N-ch open-drain output (sink driver)

NPN-O.C: NPN open-collector output (sink driver)

Motor Driver

Type number	Function		Recommended operating voltage range (V)	Output current (A)	Package	Main application
μ PD16804	Control the revolution direction of the DC motor	H Bridge 1 circuit	3.0 to 7.5	0.5	• 16-pin SOP	Camera motor
μ PD16805		H Bridge 1.5 circuits		1.0		
μ PD16823				0.5	• 20-pin SOP	

Image IC

Type number	Function	Package
μ PD42101	NTSC high speed line buffer	• 24-pin DIP • 24-pin SOP
μ PD42102	PAL high speed line buffer	• 24-pin DIP • 24-pin SOP
μ PD42280	2M bits high speed field buffer (256K words ∞ 8 bits)	• 28-pin ZIP • 28-pin SOP
μ PD72020	Graphics display controller	• 40-pin DIP • 52-pin QFP
μ PD72123	Advanced graphics display controller	• 84-pin QFJ • 94-pin QFP
μ PD72185	Advanced compression expansion engine	• 64-pin shrink DIP • 68-pin QFJ • 80-pin QFP
μ PD72186	Advanced compression expansion engine	• 100-pin QFP
μ PD72187	Advanced Bi-level image compression expansion	• 100-pin PQFP

MPEG IC

Type number	Function	Package
μ PD61000	MPEG1 Audio Decompression LSI	• 100-pin PQFP
μ PD61010	MPEG1 Audio/Video Decompression LSI	• 160-pin PQFP

Audio IC

■ Radio frequency amplification

Type number	Recommended operating voltage range (V)	Function					Recommended application Car radio	Package
		AM tuner	FM front end	FM IF amplification	FM detection	Other functions		
μ PC2535	7.5 to 8.5			●	●	Quadrature detection Internal NC+MPX	●	• 48-pin QFP
μ PC2533	7.5 to 8.5	●				Double super heterodyne DTS use	●	• 36-pin SOP

■ FM stereo demodulation

Type number	Recommended operating voltage range (V)	Voltage gain (monaural)	Function			Recommended application Car radio	Package
			Pilot canceler	Lamp driving	Noise canceler		
MC-5720 MC-5720A	7.5 to 15	-1 dB	●	●	●	●	• 16-pin SIP

■ Pre-amplifier

Type number	Recommended operating voltage range (V)	Function				Recommended application		Package
		Play back amplifier	Recording amplifier	MIC amplifier	Other functions	Radio cassette recorder	Car radio	
μ PC1228	6 to 16	●			Dual	●	●	• 8-pin SIP
μ PC1313	4 to 15	●	●		Dual, ALC	●	●	• 9-pin SIP

■ Power amplifier

Type number	Recommended operating voltage range (V)	Electrical characteristics (typical value)			Function	Recommended application			Package
		P _o (W)	V _{cc} (V)	R _L (Ω)		Home stereo	Radio cassette recorder	Car radio	
μ PC1188	± 17 to ± 23	18	± 22	8		●			• 10-pin SIP
μ PC1238	± 6 to ± 15	8.4	± 13	8		●			• 5-pin V-DIP
μ PC1308	9 to 16	15	13.2	4	BTL, standby switch			●	• 14-pin V-VIP
μ PC1310	9 to 16	5.8	13.2	4	Dual, standby switch			●	• 14-pin V-DIP
μ PC1316	3 to 16	1.2	9	8	Dual		●		• 14-pin DIPTAB
		0.5	6	8	Low pop noise				
μ PC1318A	9 to 16	20	13.2	4	BTL, standby switch			●	• 14-pin V-DIP
μ PC2002	8 to 18	4.5	13.2	4	Low pop noise			●	• 5-pin V-DIP
μ PC2500A	9 to 16	40	13.2	2	BTL, standby switch			●	• 12-pin SIP
		24	13.2	4					
μ PC2502	9 to 16	19	13.2	4	BTL, DUAL, standby switch			●	• 15-pin V-DIP
μ PC2505	9 to 16	40	13.2	2	BTL, standby switch Low pop noise			●	• 12-pin SIP
		24	13.2	4					
μ PC2506	9 to 16	40	13.2	2	BTL, standby switch Low pop noise differential input			●	• 15-pin V-DIP
		24	13.2	4					

Audio IC

■ D/A converter for audio system

Type number	Recommended operating voltage range (V)	Function	Recommended application			Package
			Home stereo	Portable	Car stereo	
μ PD6376	4.5 to 5.5	16-bit D/A converter	●	●	●	• 16-pin DIP • 16-pin SOP
μ PD6379	3.0 to 5.5	16-bit D/A converter	●	●	●	• 8-pin SOP
μ PD63200	4.5 to 5.5	18-bit D/A converter	●	●	●	• 16-pin SOP
μ PD63210	3.0 to 5.5	16-bit D/A converter with digital filter	●	●	●	• 28-pin SOP

■ DSP for audio system

Type number	Recommended operating voltage range (V)	Function	Recommended application			Package
			Home stereo	Portable	Car stereo	
μ PD6382	4.5 to 5.5	DSP for audio (19 bit)	●	●	●	• 80-pin QFP
μ PD6383	4.75 to 5.5	DSP for audio (24 bit)	●	●	●	• 100-pin QFP
μ PD6384	4.5 to 5.5	Expander/Compressor DSP (19-bit)	●	●	●	• 16-pin SOP

■ Device kit for CD

Type number	Recommended operating voltage range (V)	Function	Recommended application			Package
			Home stereo	Portable	Car stereo	
μ PC2572	4.5 to 5.5	RF amp, error amp, APC for CD player			●	• 36-pin SOP
μ PD63702	4.5 to 5.5	Digital servo, data processor, DAC for CD player			●	• 80-pin QFP
μ PD63703	4.5 to 5.5	Digital servo, data processor, ATT for CD player			●	• 80-pin QFP

■ Other functions

Type number	Recommended operating voltage range (V)	Function	Recommended application			Package
			Home stereo	Tape deck	Radio cassette recorder	
μ PC1225	± 18 to ± 36	30 to 50 W power amplifier driver	●			• 10-pin SIP
μ PC1237	25 to 60	Stereo power amplifier protection circuit	●			• 8-pin SIP
μ PC1270	± 18 to ± 36	30 to 50 W power amplifier driver	●			• 10-pin SIP
μ PC1297	8 to 18	Dolby HX PRO system		●		• 18-pin S-DIP
μ PC1298	± 20 to ± 46	50 to 80 W power amplifier driver	●			• 14-pin V-DIP
μ PC1330	4.5 to 14.4	Head selection switch circuit		●		• 9-pin SIP • 14-pin SOP
μ PC1342	± 20 to ± 52	50 to 110 W power amplifier driver	●			• 14-pin V-DIP
μ PC2560	8.1 to 13.2	Surround, Vocal cancel, Bass boost	●		●	• 36-pin SSOP
μ PC2581	± 20 to ± 75	100 to 130 W dual power amplifier driver	●			• 15-pin V-DIP

★: Under development

TV IC

■ **Tuner**

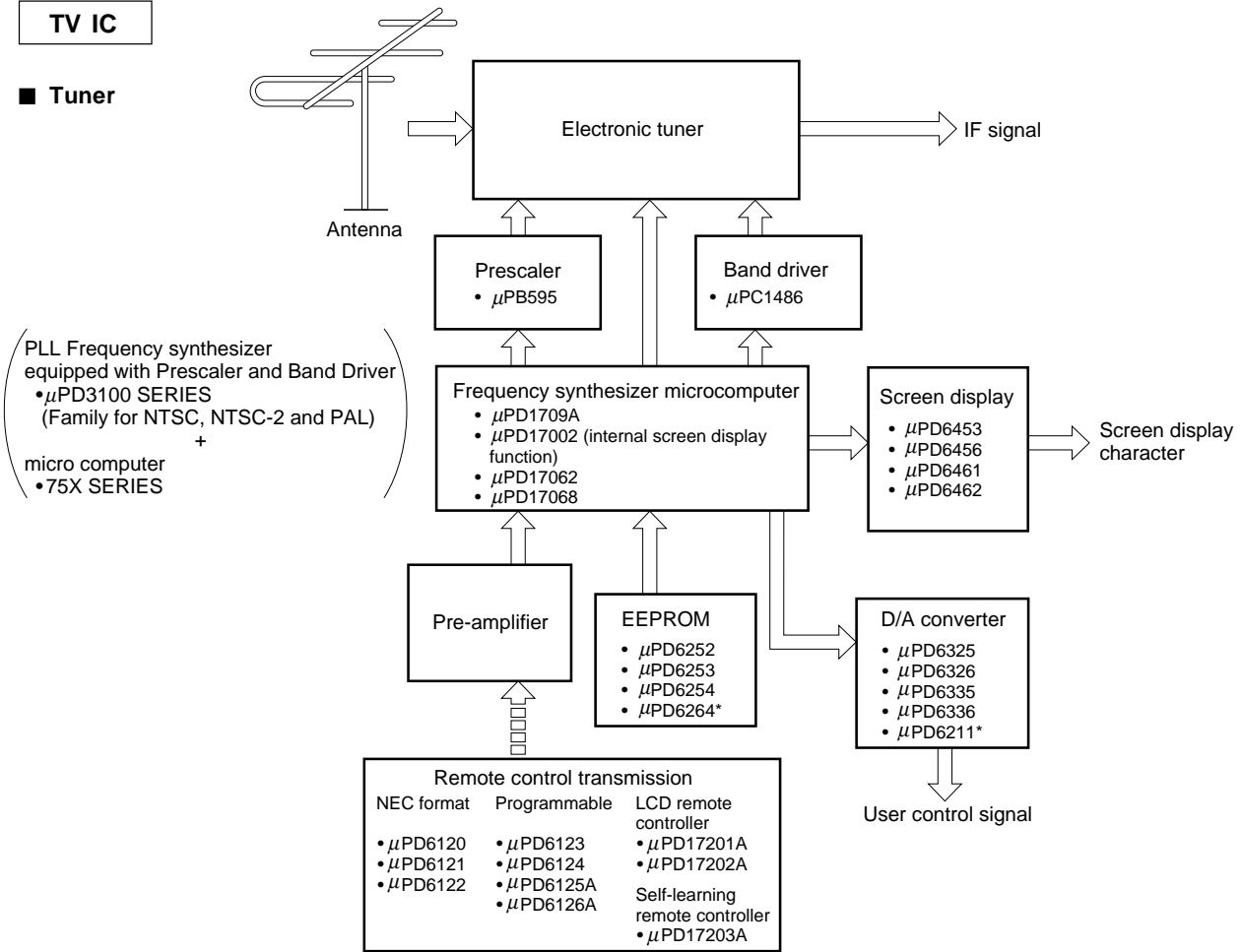

■ **Video/audio signal processing**

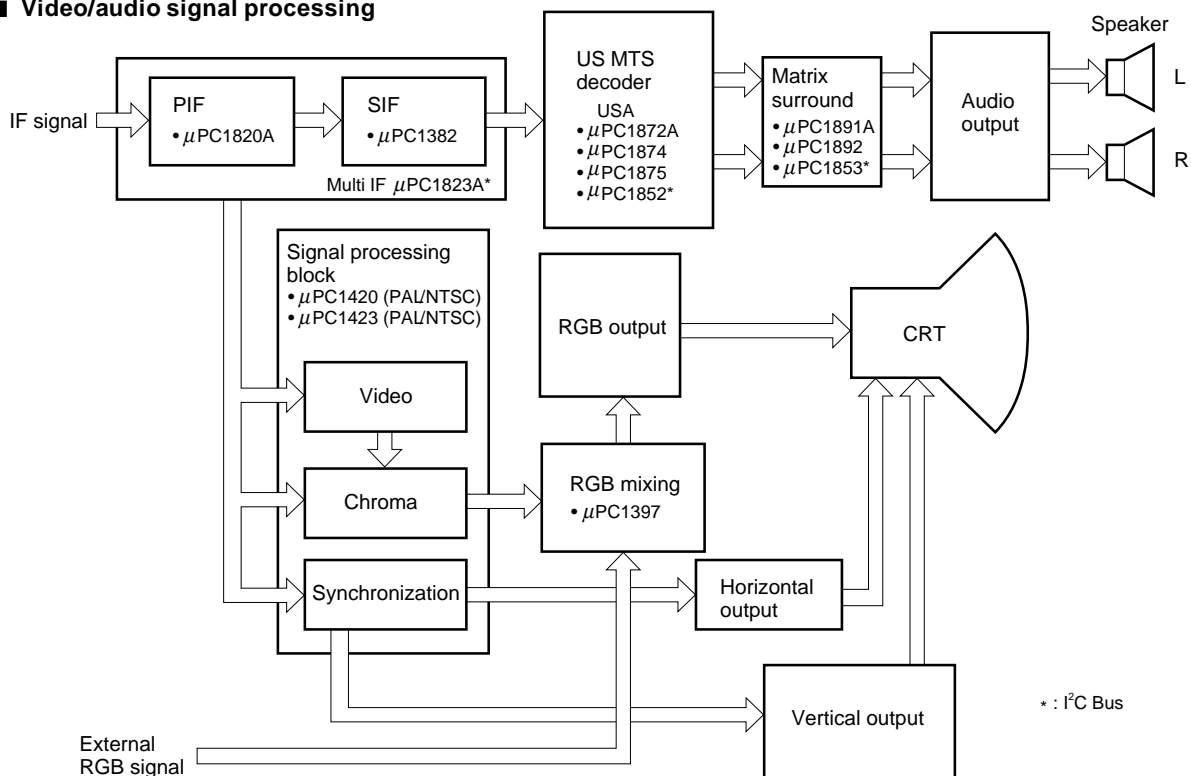

TV IC

■ US MTS Decoder

US MTS: Multi Television Sound for USA specifications

Type number	Function	Package
μ PC1872A	dbx NR, SAP Decoder, Normal Output	• 42-pin SDIP • 48-pin QFP
μ PC1874	dbx NR, Stereo only	• 28-pin SDIP
μ PC1875	Input Selector (1 ch), dbx NR, Stereo only	• 30-pin SDIP
μ PC1851	I ² C Bus, Input Selector (3 ch), dbx NR, SAP Decoder, Tone/Volume control	• 42-pin SDIP
μ PC1852A	I ² C Bus, dbx NR, SAP Decoder, Normal Output	• 28-pin SDIP

■ Matrix Surround

Type number	Function	Package
μ PC1891A	Matrix Surround (Phase Shift)	• 20-pin DIP
μ PC1892	Matrix Surround (Phase Shift), Tone/Balance/Volume, L + R output	• 30-pin SDIP
μ PC1853	I ² C bus, BASS boost, Matrix Surround, Tone/Balance/Volume, Audio output, L + R output	• 30-pin SDIP

Digital Image IC

■ Three-Dimensional Y-C separation system block diagram

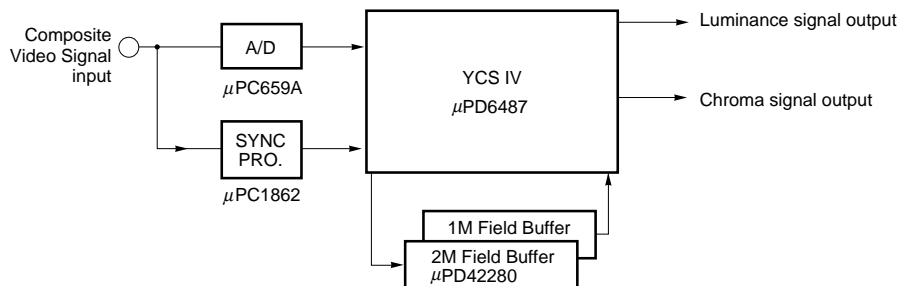

■ 3DYC LSI

Type number	Function	Package
μ PD6487	3D Dimensional Y/C separation (I ² C Bus)	• 100-pin QFP

■ Clock generator

Type number	Function	Package
μ PC1860	Burst signal locked clock generator	• 36-pin SOP
μ PC1862	Burst signal locked clock generator (External Burst gate input available)	• 36-pin SOP

■ Analog Frontend IC

Type number	Function	Package
μ PC1830	5 V operation chroma decoder NTSC/PAL, 525/625 line, 50/60 Hz selectable, Matrix circuit	• 42-pin SOP

Multisync Monitor IC

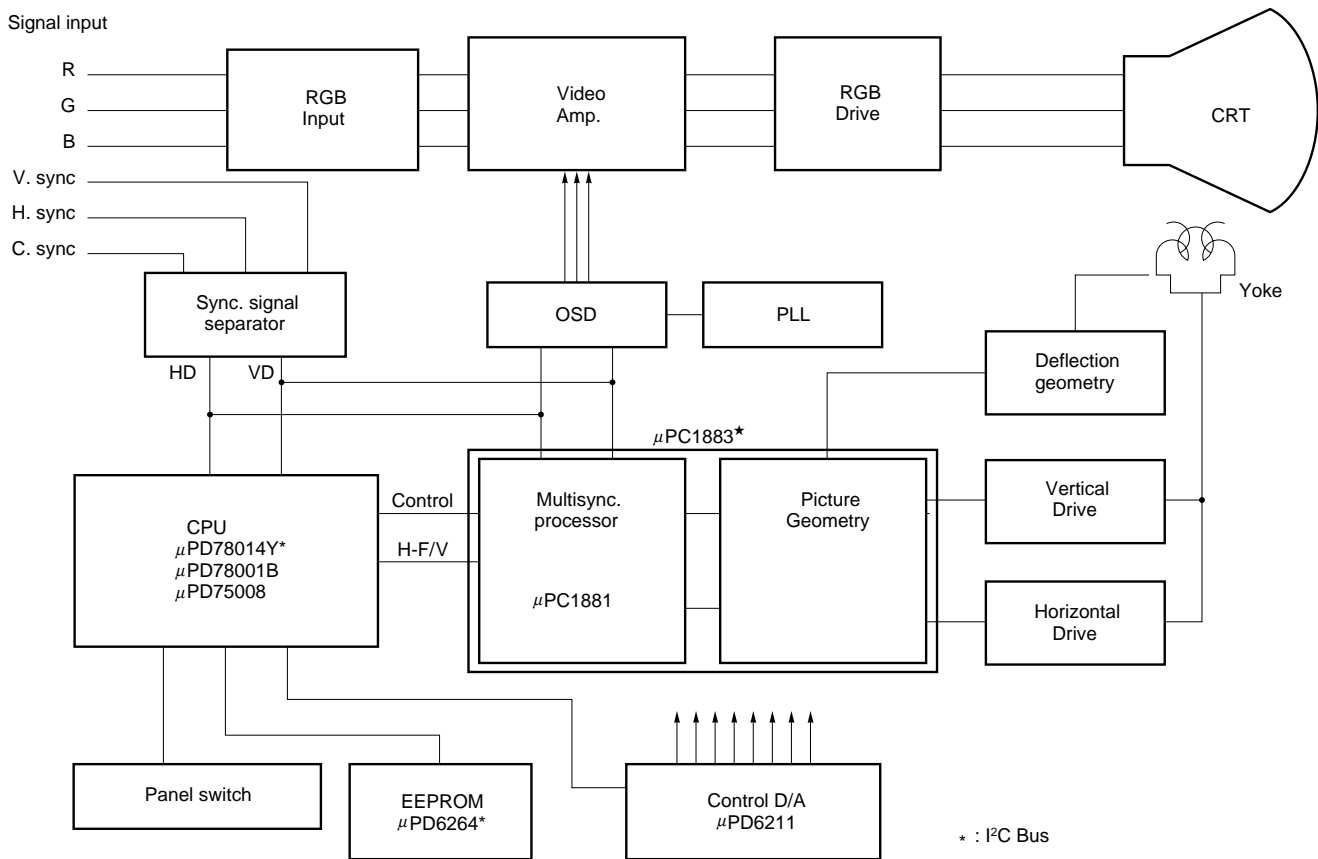

■ Multisync. monitor IC

Type number	Function	Package
μPC1881	Horizontal Vertical sync. processor	• 30-pin SDIP
μPC1883*	Horizontal Vertical sync. processor, Picture geometry processor	• 30-pin SDIP

*: Under development

On-Screen Character Display IC

■ Video type

Function \ Type number	μ PD6450	μ PD6454	μ PD6458	μ PD6464	μ PD6465
Number of character types	128 (ROM)	256 (ROM)	128 (ROM)	128 (ROM)	256 (ROM)
Number of display characters	288 (12 lines ∞ 24 digits)				
Character configuration	12 ∞ 18				
Character color	Single (White)	The level of a character can be set in 9 stages per field (from white to black)		Single (white, the luminance level of a character can be set in 2 stages.)	
Character size	1 dot/1H, 2H, 3H, 4H (per line)			1 dot/1H, 2H (per line)	
Internal video signal color	White/Black/Red/ Green/Blue	8 color		White/Black/Blue/Green	
Background	None/Fringed/Squared/Solid (per field)				
Applicable video signal mode	NTSC/PAL			NTSC/PAL/PAL-M/SECAM	
Supply Voltage	4.5 to 5.5 V				
Package	<ul style="list-style-type: none"> • 18-pin DIP (300 mil) • 20-pin SOP (375 mil) 			<ul style="list-style-type: none"> • 24-pin SDIP (300 mil) • 24-pin SOP (375 mil) 	

- Internal sync. process circuit (μ PD6454, μ PD6458)

■ RGB type

Function \ Type number	μ PD6451A	μ PD6453	μ PD6456	μ PD6461	μ PD6462	μ PD6466
Number of character types	128 (ROM)	240 (ROM) 16 (RAM)	128 (ROM)	256 (ROM)	128 (ROM)	512 (ROM)
Number of display characters	288 (12 lines ∞ 24 digits)					
Character configuration	12 ∞ 18					
Character color	8 colors		Single color (White)	8 colors		
Character size (per line)	1 dot/1H, 2H, 3H, 4H		1 dot/1H, 2H			1 dot/1H, 2H, 3H, 4H
Character color reverse (per character)	None		Black character/No fringed			Black character/ No fringed White character/ Fringed
Background (per frame)	None Square (8 colors) Solid (8 colors)		None Square (Black) Solid (Black)	None Square (8 colors) Solid (8 colors)		
Fringed (per frame)	Single color (Black)	Two colors (Black, White)	Single color (Black)	Two colors (Black, White)		
Supply voltage	4.5 to 5.5 V		3.0 to 5.5 V	2.7 to 5.5 V		
Package	<ul style="list-style-type: none"> • 18-pin DIP (300 mil) • 20-pin SOP (375 mil) 	<ul style="list-style-type: none"> • 20-pin DIP (400 mil) • 20-pin SOP (375 mil) 	<ul style="list-style-type: none"> • 16-pin SOP (300 mil) • 16-pin SOP (375 mil) 	<ul style="list-style-type: none"> • 20-pin SSOP (300 mil) • 24-pin SOP (375 mil) 	<ul style="list-style-type: none"> • 20-pin SSOP (300 mil) 	<ul style="list-style-type: none"> • 20-pin SOP (375 mil)

- Double speed TV switching is possible by command (μ PD6451A, μ PD6453)
- Making ideally suited for camcoders (μ PD6461, μ PD6462)
- μ PD6461 and μ PD6462 are commands convertible and pins convertible for 20-pin SSOP package.
- μ PD6466 has a blue background and character mirror reverse function.

VCR IC

■ Typical VCR LSI block diagram

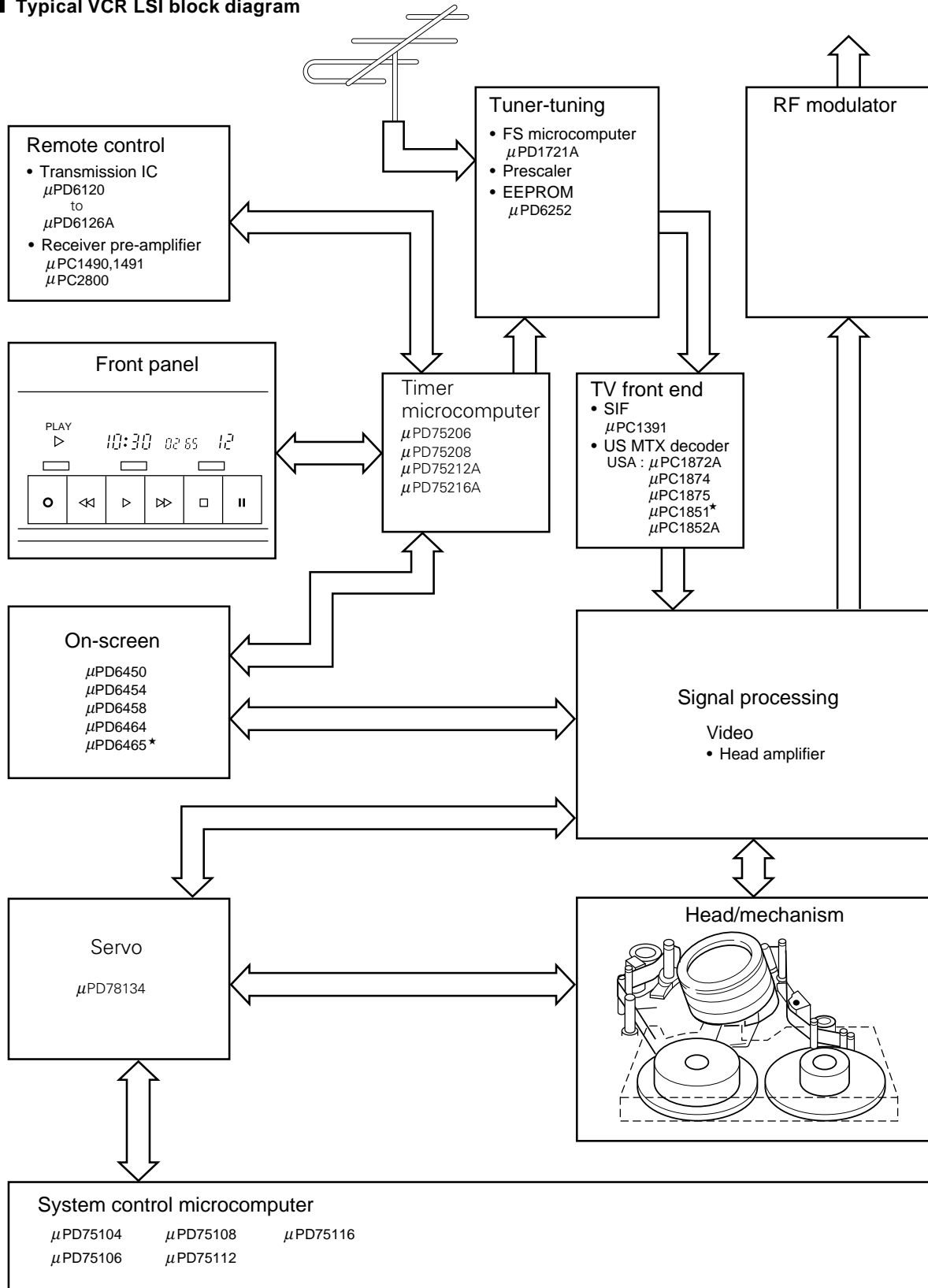

★ : Under development

Video Camera IC

■ CCD driver circuit

Type number	Function	Package
μ PD16501	Area sensor vertical drive interface	• 16-pin SOP
μ PD16502	Area sensor vertical drive interface	• 20-pin SOP
μ PD16503	Area sensor VOD shutter driver	• 8-pin SOP
μ PD16506	Area sensor vertical, VOD shutter driver	• 20-pin SOP • 20-pin SSOP
μ PD16510	Area sensor vertical, VOD shutter driver, for low voltage logic	• 22-pin SSOP

■ AGC process amplifier

Type number	Function	Package
μ PC2372	3ch AGC-process amplifier circuit	• 88-pin QFP

■ Sample and hold circuit



Type number	Function	Package
μ PC2394	Dedicated area sensor use sample and hold circuit	• 8-pin SOP

Remote Control IC

■ Infrared remote control preamplifiers IC

Type number	Supply voltage	Features	Package	Remarks
μ PC2800A μ PC2801A μ PC2803	5 V \pm 10%	Internal high trap circuit	• 8-pin SOP	Active low type Active high type Active low type

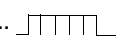
■ Infrared remote control IC

Type number	μ PD6121-001	μ PD6122-001
Operating voltage range	2.0 to 3.3 V	
Operation clock (f _{osc})	400 to 500 kHz ceramic oscillator	
Transmission format	Leader	Custom code 16-bit
	Data code 8-bit	Data code 8-bit
Modulation mode	P.P.M. 0 ...  1...  38 kHz • carrier modulation(f _{osc} = 455 kHz)	
Custom code	16-bit set*	
Data code	32 ∞ 2	64 ∞ 2
Number of keys	32	64
Package	• 20-pin SOP	• 24-pin SOP

*: All codes except code "00FFH" are managed by NEC.

Clock IC

Type number	Function	Features	Package
μ PD4990A	Serial I/O real-time clock	Wide operating voltage range, low power consumption	• 14-pin DIP • 16-pin SOP
μ PD4991A	4-bit parallel I/O real-time clock	Wide operating voltage range, low power consumption	• 18-pin DIP • 20-pin SOP
μ PD4992	8-bit parallel I/O real-time clock	Wide operating voltage range, low power consumption	• 20-pin DIP • 20-pin SOP

Rotary Encoder IC

Type number	Function	Features	Package
μ PD4701A	12-bit incremental encoder counter	Direct mouse connection is possible	• 20-pin DIP • 24-pin SOP
μ PD4702	8-bit incremental encoder counter	High speed count $f = 3.6$ MHz	• 20-pin DIP • 20-pin SOP
μ PD4704	μ PD4702 extension 8-bit counter		• 20-pin DIP • 20-pin SOP

A/D Converter IC**■ A/D Converter**

Type number	Resolution (bits)	Linearity (%FSR)	Conversion time (μ s)	Supply voltage (V)	Data format	Output format	Package	Remarks
μ PC650	12	0.05	45	+5 -15	Binary	12-bit parallel	• 28-pin DIP	Successive approximation
μ PD7001	8	0.8	140 (TYP.)	+5	Binary	Serial	• 16-pin DIP	Parallel approximation, microcomputer I/F, 4-channel MPX input
μ PD7002	10	0.2	15 (ms)	+5	Binary	8-bit parallel	• 28-pin DIP	Integrative approximation, microcomputer I/F, 8-channel MPX input
μ PD7003	8	0.5	4	+5	Binary	8-bit parallel	• 24-pin DIP	Parallel approximation, microcomputer I/F
μ PD7004	10	0.1	104	+5	Binary 2's complement	8-bit parallel/serial	• 28-pin DIP (400mil)	Successive approximation, microcomputer I/F, 8-channel MPX input

■ A/D Converter for Video processing

Type number	Resolution (bits)	Linearity (%FSR)	Sampling time (MSPS)	Supply voltage (V)	Data format	Output format	Package	Remarks
μ PC668*	10	0.2	20	+5	Binary	10-bit parallel	• 30-pin SOP	Parallel approximation Video processing
μ PC659A	8	0.2	20	+5	Binary	8-bit parallel	• 24-pin SOP	Parallel approximation Video processing
μ PC660	6	0.8	20	+5	Binary	6-bit parallel	• 16-pin SOP	Parallel approximation Video processing
μ PC661	6	0.8	20	+5	Binary	6-bit parallel	• 24-pin SOP	4-input multiplexer Video processing
μ PD6952*	10	0.2	20	+5	Binary	10-bit parallel	• 24-pin SOP	Parallel approximation Video processing

* : Under development

D/A Converter IC

■ D/A Converter

Type number	Resolution (bits)	Linearity (%FSR)	Settling time (μ s)	Supply voltage (V)	Input format	Output format	Package	Remarks
μ PC610	10	0.2	6	± 15	Sign+Binary	Voltage output	• 18-pin DIP	Parallel input
μ PC624	8	0.19	150 (ns)	± 5 to ± 15	Binary	Current output	• 16-pin DIP	Parallel input
μ PC648	12	0.05	400 (ns)	± 15	Binary	Current output	• 20-pin DIP	Parallel input
μ PD6325 μ PD6335	6 (4 circuits)	Monotonicity	10	+5 to +15 +5	Binary	Voltage output	• 16-pin DIP • 16-pin SOP	Serial input, CMOS
μ PD6326 μ PD6336	6 (8 circuits)	Monotonicity	10	+5 to +15 +5	Binary	Voltage output	• 16-pin DIP	Serial input, CMOS
μ PD6211	8 (8 circuits)	0.39	10	+5	Binary	Voltage output	• 20-pin DIP • 20-pin SOP	I ² C-bus compatible Internal Output CMOS' Buffer
μ PD7011	8	0.2 0.4	3	+5	Binary 2's complement	Current output	• 18-pin DIP	Parallel/serial input microcomputer I/F, NMOS

■ D/A Converter for Video processing

Type number	Resolution (bits)	Linearity (%FSR)	Sampling rate (MSPS)	Supply voltage (V)	Input format	Output format	Package	Remarks
μ PC667	10	0.1	60	+5	Binary	Voltage output	• 30-pin SDIP	Parallel input Video processing
μ PC662	8 (3 circuits)	0.2	35	+5	Binary	Voltage output	• 48-pin QFP	Parallel input, 3 circuits Video processing
μ PC664	8 (2 circuits)	0.2	35	+5	Binary	Voltage output	• 36-pin SOP	Parallel input, 2 circuits Video processing
μ PC665	8	0.2	35	+5	Binary	Voltage output	• 16-pin SOP	Parallel input Video processing
μ PC666	6 (3 circuits)	0.8	35	+5	Binary	Voltage output	• 36-pin SOP	Parallel input, 3 circuits Video processing

Line Driver Receiver IC

Type number	Function	Features	Package
μ PD4711B	RS-232 line driver/receiver Drivers: 2, Receivers: 2	+5V power source, standby function	• 20-pin DIP • 20-pin SOP
μ PD4712	RS-232 line driver/receiver Drivers: 4, Receivers: 4	+5V power source, standby function	• 28-pin DIP • 28-pin SOP
μ PD4713A	RS-232 line driver/receiver Drivers: 3, Receivers: 3	+5V power source, standby function	• 24-pin DIP • 24-pin SOP
μ PD4714A	RS-232 line driver/receiver Drivers: 3, Receivers: 5	+5V power source, standby function	• 28-pin DIP • 28-pin SOP
μ PD4715A	RS-232 line driver/receiver Drivers: 5, Receivers: 3	+5V power source, standby function	• 28-pin DIP • 28-pin SOP
μ PD4721	RS-232 line driver/receiver Drivers: 2, Receivers: 2	+3.3V or +5V power source, standby function	• 20-pin SSOP
μ PD4722	RS-232 line driver/receiver Drivers: 4, Receivers: 4	+3.3V or +5V power source, standby function	• 30-pin SSOP
μ PD4723	RS-232 line driver/receiver Drivers: 3, Receivers: 3	+3.3V or +5V power source, standby function	• 30-pin SSOP
μ PD4724	RS-232 line driver/receiver Drivers: 3, Receivers: 5	+3.3V or +5V power source, standby function	• 30-pin SSOP
μ PD4726	RS-232 line driver/receiver Drivers: 4, Receivers: 7	+5V power source, standby function, for PC	• 36-pin SSOP

Vehicle Communication IC

Type number	Function	Features	Package
μ PD72005*	CAN (Controller Area Network) Controller	Support the standard and extended message identifiers in CAN spec 2.0 2-wire serial communication bus Multimaster architecture Multicast message transfer Transfer rate up to 1M bit per second	<ul style="list-style-type: none">• 52-pin QFP• 52-pin QFJ

★: Under development

General Purpose Linear IC

Operational Amplifier	122
Comparator	123
Fixed Output Voltage, 3-Terminal Regulator	123
Variable Output Voltage Regulator	124
Regulator with System Reset	124
High Precision Reference Voltage	124
Switching Regulator Control Circuit.....	125
Functional Block	125

5

Operational Amplifier

Type number		Function*1			Recommended power supply voltage*2 (V)	Common mode input voltage range TYP. (V) T _A = +25 fC	Input stage transistor	GND Input/Output on single power	Low V _{io} Low T _A drift	Low input bias current	High speed	Wide band	Low noise	Low power	Packages*3				Number of pins
Communication/industry use	General use	Single	Dual	Quad											D ED	C	G2	HA	
μPC151	μPC741	○			±7.5 to ±16	V ⁻ +2 to V ⁻ -0.5	NPN		○						○	○	○		8
μPC251	μPC1458		○		±7.5 to ±16	V ⁻ +2 to V ⁻ -0.5	NPN		○						○	○	○		8
μPC254		○			±3 to ±16	V ⁻ +1 to V ⁻ -1	NPN		◎	◎			○		○				8
μPC354		○			±3 to ±16	V ⁻ +1 to V ⁻ -1	NPN		◎	◎			○		○				8
μPC454			○		±3 to ±16	V ⁻ +1 to V ⁻ -1	NPN		◎	◎			○		○				14
μPC815		○			±3 to ±20	V ⁻ +1.5 to V ⁻ -2.5	NPN		◎	○			◎		○	○			8
μPC816		○			±3 to ±20	V ⁻ +1.5 to V ⁻ -2.5	NPN		◎	○	○	◎	◎		○	○			8
μPC157	μPC301A	○			±5 to ±16	V ⁻ +2 to V ⁺	NPN		○						○	○			8
μPC159	μPC318	○			±5 to ±18	V ⁻ +2.5 to V ⁻ -2	NPN				◎	◎			○	○			8
μPC802	μPC4250	○			±1 to ±16	V ⁻ +0.2 to V ⁻ -0.6	PNP		○	○				◎		○	○		8
μPC801	μPC4081	○			±5 to ±16	V ⁻ +2.3 to V ⁺	J-FET			◎	○	○				○	○		8
μPC803	μPC4082		○																
μPC804	μPC4084			○												○			14
μPC811		○			±5 to ±16	V ⁻ +3 to V ⁻ -1	J-FET		○	◎	○	○	○			○	○		8
μPC812			○		±5 to ±16	V ⁻ +3 to V ⁻ -1	J-FET		○	◎	○	○	○			○	○		8
μPC813		○			±5 to ±16	V ⁻ +3 to V ⁻ -1	J-FET		○	◎	◎	○	○			○	○		8
μPC814			○		±5 to ±16	V ⁻ +3 to V ⁻ -1	J-FET		○	◎	◎	○	○			○	○		8
μPC821	μPC4071	○			±5 to ±16	V ⁻ +2 to V ⁺	J-FET			◎	○	○	○			○	○		8
μPC822	μPC4072		○																
μPC824	μPC4074			○												○	○		14
μPC831	μPC4061	○			±2 to ±16	V ⁻ +2 to V ⁺	J-FET			◎				○		○	○		8
μPC832	μPC4062		○																
μPC834	μPC4064			○												○	○		14
μPC258	μPC4558		○		±4 to ±16	V ⁻ +1 to V ⁻ -1	PNP		○			○	○			○	○	○	8
μPC458	μPC4741			○															
μPC259	μPC4560		○		±4 to ±16	V ⁻ +1 to V ⁻ -1	PNP		○			○	○			○	○		8
	μPC4556		○		±4 to ±16	V ⁻ +1 to V ⁻ -1	PNP		○		○	◎	○			○	○		8
	μPC4557		○		±4 to ±16	V ⁻ +1 to V ⁻ -1	PNP		○			○	○			○			8
	μPC4559		○		±4 to ±16	V ⁻ +1 to V ⁻ -1	PNP		○			○	○			○			8
	μPC4570		○		±4 to ±16	V ⁻ +1 to V ⁻ -1	PNP		○		○	◎	◎			○	○	○	8*4
	μPC4574			○															
	μPC4572		○		±2 to ±7	V ⁻ +1 to V ⁻ -1	PNP		○		○	◎	◎			○	○	○	8*4
μPC1251	μPC358		○		+3 to ±30	GND to V ⁻ -1.5	PNP	○		○				○		○	○	○	8*4
μPC451	μPC324			○															
μPC452	μPC3403			○	+3 to ±32	GND to V ⁻ -1.5	PNP	○		○						○	○		14
μPC842			○		±3 to ±32	GND to V ⁻ -1.8	PNP	○			○	○				○	○		8
μPC844				○															

○ : Recommended for designing ◎ : High performance ◎ : Very high performance

*1 : Single type has a offset adjust pin.

*2 : For product indicated by +/- voltage, single supply voltage operation is possible if the input/output voltage range is observed.

*3 : C, D, ED, G2 or HA shows Package Type, as follows.

- C : Plastic DIP (300 mil)
- D, ED: Ceramic DIP (300 mil)
- G2 : Plastic SOP (225 mil)
- HA : 9-pin plastic slim SIP

*4 : HA has 9 pins.

Comparator

Type number		Function			Recommended power supply voltage (V)	Common mode input voltage range TYP. (V) T _A = +25 fC	Input stage transistor	GND Input on single power	High speed	Low power	Output circuit type		Packages*1				Number of pins
Communication/industry use	General use	Single	Dual	Quad							Open-collector	Emitter-follower	D ED	C	G2	HA	
μPC271	μPC311	○			+5 to +32	V ⁻ +0.3 to V ⁻ -1.2	PNP		○		○	○	○	○	○	8	
μPC272	μPC319		○		+5 to +32	V ⁻ +2 to V ⁻ -2	NPN		○		○		○	○	○	14	
μPC277	μPC393		○							○			○	○	○	8*2	
μPC177	μPC339			○	+2 to +32	GND to V ⁻ -1.5	PNP	○		○	○		○	○	○	14	

*1 : C, D, ED, G2 or HA shows Package Type, as follows.

- C : Plastic DIP (300 mil)
- C : Plastic DIP (300 mil)
- D, ED: Ceramic DIP (300 mil)
- G2 : Plastic SOP (225 mil)
- HA : 9-pin plastic slim SIP

*2 : HA has 9 pins.

Fixed Output Voltage, 3-Terminal Regulator

Type	Type number	Output current (A)	Output voltage (V)												Absolute maximum ratings		Package	Remarks		
			3	3.3	4	5	6	7	8	9	10	12	15	18	24	Input voltage (V)			Total power dissipation (W)*1	
Positive voltage output	μPC78L00	0.1				○	○	○									30	0.7/2*3	• TO-92 • SOT-89	
																				35
	μPC78N00	0.3				○			○								35	12.5	• TO-126	
																	40			
	μPC78M00A	0.5				○	○	○	○	○	○	○	○	○			35	15	• MP-45*2	Improved version of μPC78M00
																	40			
	μPC7800A	1.0				○			○								35	15	• MP-45*2	Improved version of μPC7800
																	40			
	μPC2600	0.5				○											35 (DC) ±100 (surge)	20	• TO-220AB	
	μPC29L00	0.1	○	○	○	○											16	0.7/2*3	• TO-92 • SOT-89	Low dropout voltage type
μPC29M00*	0.5	○	○		○											20	1.0/2.0*4 15	• MP-3 • MP-3Z*5 • MP-45*2	Low dropout voltage type	
μPC2900*	1.0	○	○		○											20	1.0/2.0*4 15	• MP-3 • MP-3Z*5 • MP-45*2	Low dropout voltage type	
μPC24A00	2.0				○											36	20	• MP-45*2	Low dropout voltage type	
μPC24M00A	0.5				○	○	○	○	○	○	○	○	○	○		36	15	• MP-45*2	Low dropout voltage type	
μPC2400A	1.0				○	○	○	○	○	○	○	○	○	○		36	15	• MP-45*2	Low dropout voltage type	
Negative voltage output	μPC79L00	0.1				○			○								-30	0.7	• TO-92	
																	-35			
	μPC79N00	0.3				○			○								-35	12.5	• TO-126	
																	-40			
μPC79M00	0.5				○			○								-35	15	• MP-45*2		
																-40				
μPC7900A	1.0				○			○								-35	15	• MP-45*2	Improved version of μPC7900	

- *1 : Limited by internal circuit
- *2 : Plastic insulated package
- *3 : With 16 cm² ∞ 0.7 mm ceramic substrate
- *4 : With 7.5 cm² ∞ 0.7 mm ceramic substrate
- *5 : Surface mount package of MP-3

*: Under development

Variable Output Voltage Regulator

Type	Type number	Output current (A)	Output voltage range (V)	Absolute maximum ratings		Package	Remarks
				Input voltage (V)	Total power dissipation (W)		
Positive voltage output	μ PC141/305*3	0.05	4.5 to 30	40	0.35, 0.5/0.35, 0.44	• 8-pin DIP (plastic/ceramic) • 8-pin SOP	
	μ PC317	1.5	1.3 to 30	40	20*1, 15*1	• TO-220AB • MP-45*2	3-pin regulator
	μ PC1093	0.15	2.5 to 36	37	0.48, 0.7, 2*4	• 8-pin SOP • TO-92 • SOT-89	Shunt regulator
	μ PC1943	0.05	1.26 to 24	25	1.6*4	• SOT-89	Shunt regulator
	μ PC1944	0.05	1.26 to 24	25	0.385, 0.56	• 8-pin SOP • TO-92	Shunt regulator
Negative voltage output	μ PC337	1.5	-1.3 to -30	-40	20*1	• TO-220AB	3-pin regulator

- *1 : Limited by internal circuit
- *2 : Plastic insulated package
- *3 : μ PC141 is for communication/industry use.
- *4 : When mounted on 16 cm² (0.7 mm thick) ceramic board

Regulator with System Reset

Type	Type number	Output current (A)	Output voltage (V)	Reset start voltage (V)	Reset output logic		Absolute maximum ratings		Package	Remarks
					Active low	Active high	Input voltage (V)	Total power dissipation (W)		
Positive voltage output	μ PC2251	0.1	3	2.85	○		12	1.2*	• TO-126 (4-pin)	Low dropout type
	μ PC2252	0.1	3	2.85		○	12	1.2*	• TO-126 (4-pin)	Low dropout type
	μ PC2253	0.1	5	2.85	○		12	1.2*	• TO-126 (4-pin)	Low dropout type
	μ PC2254	0.1	5	2.85		○	12	1.2*	• TO-126 (4-pin)	Low dropout type
	μ PC2255	0.1	5	4.75	○		12	1.2*	• TO-126 (4-pin)	Low dropout type
	μ PC2256	0.1	5	4.75		○	12	1.2*	• TO-126 (4-pin)	Low dropout type
	μ PC2260	0.5	5	4.85	○		35	20*	• TO-220 (5-pin)	Low dropout type
Supervisory for Micro-processor	μ PC2270A	-	-	4.3	○	○	8	0.35	• 8-pin DIP	Manual Reset Input
								0.44	• 8-pin SOP	
								0.35	• 9-pin Slim SIP	
	μ PC1074A	0.01	2 ~ 5.18	Adjustable	○		40	0.5	• 16-pin SOP	Watch-dog Timer

- *: Limited by internal circuit

High Precision Reference Voltage

Type number	Input voltage range (V)	Output voltage (V)	Output current (mA)	Total power dissipation (mW)	Output voltage vs. temperature (ppm/fC)	Package
μ PC1060	4.5 to 40	2.5 ±0.025	10	350, 500	40	• 8-pin DIP (plastic, ceramic)

Switching Regulator Control Circuit

Type number	Input voltage range (V)	Absolute maximum ratings		Package	Output circuit operation mode	Applications
		Output current (mA)	Total power dissipation (W)			
μ PC494	7 to 40	250	1, 0.78* ² , 0.65* ²	<ul style="list-style-type: none"> • 16-pin DIP (plastic) • 16-pin SOP*¹ 	Push-pull/single selectable	General purpose
μ PC1094	11 to 24	1200 (peak)	0.57, 0.55	<ul style="list-style-type: none"> • 14-pin DIP (plastic) • 14-pin SOP 	Totem pole circuit configuration Single mode	Can operate up to 500 kHz General purpose
μ PC1099	11.5 to 24	1200 (peak)	1, 0.694	<ul style="list-style-type: none"> • 16-pin DIP (plastic) • 16-pin SOP 	Totem pole circuit configuration Single mode	Can operate up to 500 kHz General purpose
μ PC1905	16.5 to 30	1200 (peak)	1, 0.694	<ul style="list-style-type: none"> • 16-pin DIP (plastic) • 16-pin SOP 	Totem pole circuit configuration Single mode	Can operate up to 500 kHz General purpose
μ PC1906	16.5 to 30	1200 (peak)	1, 0.694	<ul style="list-style-type: none"> • 16-pin DIP (plastic) • 16-pin SOP 	Totem pole circuit configuration Single mode	Can operate up to 500 kHz General purpose
μ PC1900	12 to 30	1200 (peak)	1.225, 0.775	<ul style="list-style-type: none"> • 24-pin DIP (plastic) • 24-pin SOP 	Totem pole circuit configuration 2 outputs	Can operate up to 500 kHz General purpose
μ PC1394	6.6 V _{TYP.} (shunt type)	10	0.15 (T _a =75°C)	<ul style="list-style-type: none"> • 14-pin DIP (plastic) • 14-pin SOP 	Single mode	TV/VCR
μ PC1100	3.6 to 40	25	1, 0.694	<ul style="list-style-type: none"> • 16-pin DIP (plastic) • 16-pin SOP 	2 outputs (synchronous control possible) If one output is shorted, both outputs will be turned OFF.	DC/DC converter
μ PC1150	3.6 to 40	25	1, 0.694	<ul style="list-style-type: none"> • 16-pin DIP (plastic) • 16-pin SOP 	2 outputs (synchronous control possible) If one output is shorted, only the output will be turned OFF.	DC/DC converter

*1 : μ PC494G is 375 mil. μ PC494GS is 300 mil.

*2 : When mounted on 5 × 5 cm² (1.6 mm thick) glass epoxy board.

Functional Block

Function	Type number	Features	Package
Analog Multiplexer	μ PD5205	Single-pole 8 position mode/double-pole 4 position mode Supply Voltage: 44 V, ON Resistance: 270 Ω TYP.	<ul style="list-style-type: none"> • 24-pin shrink DIP • 24-pin SOP
Precision Timer	μ PC1555	CR Timer, Operating Temperature: -20 ~ +80°C Supply Voltage: 4.5 ~ 16 V, Free Running Frequency: 0.1 ~ 100 kHz	<ul style="list-style-type: none"> • 8-pin DIP • 8-pin SOP
	μ PC617	CR Timer, Operating Temperature: -20 ~ +80°C Supply Voltage: 4.5 ~ 16 V, Free Running Frequency: 0.1 ~ 100 kHz	<ul style="list-style-type: none"> • 8-pin DIP • 8-pin SOP
	μ PD5555	CMOS CR Timer, CMOS Type of μ PC1555 Supply Voltage: 3 ~ 16 V, Free Running Frequency: 0.1 ~ 500 kHz	<ul style="list-style-type: none"> • 8-pin DIP • 8-pin SOP
	μ PD5556	CMOS CR Timer Dual Type of μ PD5555	<ul style="list-style-type: none"> • 8-pin DIP • 8-pin SOP
Sample and Hold	μ PC398	Sample and Hold, Operating Temperature: 0 ~ +70°C Supply voltage: $\pm 5 \sim \pm 15$ V, Acquisition Time: 2.5 μ s TYP.	<ul style="list-style-type: none"> • 8-pin DIP
	μ PC649	Sample and Hold, Operating Temperature: -20 ~ +70°C Supply voltage: $\pm 5 \sim \pm 15$ V, Acquisition Time: 2.5 μ s TYP.	<ul style="list-style-type: none"> • 8-pin DIP

EMPTY PAGE

Transistor/Diode/Thyristor

Transistor	128
• Quick Reference by Package	128
• Quick Reference Table by Function/Application	138
Field Effect Transistor	145
• Small Signal FET	145
• Power MOS FET	148
Transistor with Internal Resistor	154
Transistor for Array	158
Power MOS IC	159
Transistor Array	159
Zener Diode	161
Thyristor	163

Quick Reference by Package

■ **TO-92 Type Transistor**

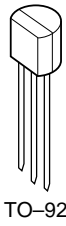

TO-92

V _{CE0} (V) I _c (A)	~15	~30	~50	~70	~100	~150	~200	~250	~400
~20 m		2SC1674							
~30 m		2SC1675	2SA1005						
~50 m	2SA1206**					2SA988 2SA992 2SC1841 2SC1845			
~100 m			2SA733 2SA987 2SA990 2SA1151 2SC945 2SC945 (L) 2SC1840 2SC1842 2SC1843 2SC2718 AA1[] AN1[]	2SA991 2SC1844	2SA675 ¹⁾		2SA1376 2SA1376A 2SC3478 2SC3478A	2SA1544	
~200 m	2SC2901**	2SA1409* (25 V/ 150 mA)	2SC3622* (150 mA) 2SC3622A* (150 mA)						
~500 m			2SC3615* (300 mA)	2SA953 2SC2002	2SA954 2SA1152 2SC2003 2SC2719				2SA1625
~1.0		2SA952 2SC2001 2SC3616* (25 V/ 700 mA) AB1[] (25 V/ 700 mA) AP1[] (25 V/ 700 mA)	2SB1116 2SD1616	AD1[] AD2[]*** AR1[] 2SB1116A (60 V) 2SD1616A (60 V) 2SD1701*** (60 V)	2SD1698 (80 V)				
~2.0		2SD1513 (16 V/2.0 A) 2SB1068 (16 V/2.0 A) AC1[] (20 V/2.0 A) AQ1[] (20 V/2.0 A)		2SD1939 (60 V/1.5 A)					
~3.0		2SB1300 (16 V/3 A) AC2[] (16 V/3 A) AQ2[] (16 V/3 A)							

1) V_{CEs} □: Darlington transistor, *: High h_{FE} transistor, **: High speed switching, ***: Contains internal zener diode

Quick Reference by Package

■ SST Type Transistor

V_{CE0} (V) I_C (A)	~15	~20	~30	~50	~120
~20 m	2SC2786	BA3[] BN3[]	2SC2787		
~50 m	2SA1459**				2SA1174 2SC2784
~100 m				2SA1175 2SC2785 2SC3623* BA1[] BN1[] BA2[] BN2[]	
~200 m	2SC3732**	2SA1410* (150 mA)		2SA1458** (40 V) 2SC3623A* (150 mA) 2SC3731** (40 V)	
~700 m		2SB810 2SD1020	BB1[] (25 V) BP1[] (25 V)		
~1.0		2SB811 2SD1021			

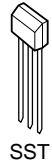

*: High h_{FE} transistor, **: High speed switching

Quick Reference by Package

■ **SP-8 Type Transistor**

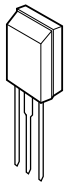

SP-8

V _{CEO} (V) I _c (A)	~16	~25	~50	~80	~140	~160	~300	~400	~600
~50 m					2SA915 2SC1940	2SA916 2SC1941			
~200 m							2SC3209 2SC4000 (250 V/ 100 mA)		
~500 m					2SA1221 2SC2958	2SA1222 2SC2959			
~700 m			2SB605 2SA1154 2SD571 2SC2721						
~1.0		2SB564 2SD471	2SA1460** 2SB734 2SC3733** 2SD774 2SD1582*	2SB984 2SB1093 2SD1312 2SD1579 2SD1697 (800 mA) 2SD1700*** (60 V/ 800 mA) 2SD1843*** (60 V)					2SA1627
~2.0	2SB733 2SD773	2SD1581*	2SD2463	2SD1779* (60 V) 2SD1780* (60 V) CE1[]*** (60 V) CE2[]* (60 V)				2SA1626	
~3.0		2SB1117			2SB1318 (100 V)				
~5.0		2SA1897							

 Darlington transistor, *: High hFE transistor, **: High speed switching, ***: Internal zener diode

Quick Reference by Package

■ MP-3 Type Transistor

V_{CE0} (V) $I_{C(DC)}$ (A)	~20	~40	~60	~100	~150	~300	~400	~600
-0.5						2SC2802	{ 2SA1400 2SC3588	
-1.0			{ 2SB963 2SD1286 2SC4337					{ 2SA1413 2SC3632
-2.0	2SD1583 ●	2SD992	2SD1164	2SC4338	{ 2SB768 2SD1033 2SD1557	2SC2885 2SC2946 2SC2946(1)	{ 2SA1412 2SC3631	
-3.0		2SB962 ◎	2SD1448 2SD1584 ● { 2SB1261 ◎ 2SD1899 ◎	2SC4339				
-5.0			{ 2SA1385 ◎ 2SC3518 ◎ 2SA1648 ◎ 2SC4332 ◎	{ 2SA1647 ◎ 2SC4331 ◎ 2SC4345			2SC4346	
10	2SA1615 ◎	{ 2SA1649 2SC4333	2SC4344	2SC4343				

□: Darlington transistor, { : Complementary pair, ●: Single High h_{FE} , ◎: Low $V_{CE(sat)}$

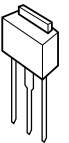

MP-3

■ MP-5 (TO-126) Type Transistor

V_{CE0} (V) $I_{C(DC)}$ (A)	~20	~45	~60	~80	~120	~160	~300	~400	~600
-1.0						{ 2SA1142 2SC2682	2SC2371 { 2SA1546 2SC4001		
-0.5							2SC2688	{ 2SA1156 2SC2752	
-1.0			{ 2SB731 2SD809(1) 2SD1630 * 2SC4340	2SB548 2SD414	{ 2SB549 2SD415				{ 2SA1486 2SC3840
-2.0		2SD1695 *	{ 2SB794 2SD985 2SB1111 * 2SD1491 *	{ 2SB795 2SD986 2SC4341	{ 2SA1220 2SC2690	{ 2SA1220A 2SC2690A			
-3.0		{ 2SB744 2SD794 2SB772 ◎ 2SD882 ◎ 2SC1449	{ 2SB744A 2SD794A 2SB1150 * 2SD1693 * 2SD1694 ● 2SB1217 ◎ 2SD1818 ◎		{ 2SA1714 2SB1149 2SD1692 2SC4342				
-5.0	2SD741 ◎		{ 2SB1151 ◎ 2SD1691 ◎						

□: Darlington transistor, { : Complementary pair, *: Internal zener diode between C-B, ◎: Low $V_{CE(sat)}$, ○: Single High h_{FE}

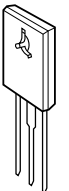

MP-5 (TO-126)

Quick Reference by Package

■ MP-25 (TO-220) Type Transistor

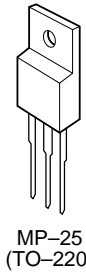

MP-25
(TO-220)

V _{CEO} (V) I _{C(DC)} (A)	-40	-60	-80	-100	-150	-200	-250	-300	-400	-800
-0.5						{ 2SA1383 2SC3514		{ 2SC1505 2SC1506 2SC1507		
-2.0		{ 2SD1481* 2SD1629*		{ 2SA1008 2SC2331 2SA985 2SC2275	{ 2SA985A 2SC2275A 2SA1006 2SC2336 2SB536 2SB537 2SD381 2SD382 2SB546A 2SB547A 2SD401A 2SD402A	{ 2SA1006A 2SC2336A	{ 2SA1006B 2SC2336B	2SA1009	{ 2SA1009A 2SC2333	
-3.0	2SD795	2SD288 2SD289								2SC3531
-5.0		{ 2SA1069 2SC2516	{ 2SA1069A 2SC2516A 2SB703 2SD743	{ 2SA1644 ⊙ 2SC4328 ⊙ 2SB601 2SD560 2SB703A 2SD743A 2SC2517				{ 2SD1162	{ 2SC2518 2SD987	
-7.0	{ 2SA1129 2SC2654	{ 2SB707 2SD568	{ 2SB708 2SD569	{ 2SA1010 2SC2334 2SC2373 2SA1645 ⊙ 2SC4329 ⊙					2SC2335	
-8.0				{ 2SA1716 2SC4496*						
-7.0				{ 2SA1717 2SA1646 ⊙ 2SC4330 ⊙						

□: Darlington transistor, { : Complementary pair, *: Internal zener diode between C-B, ⊙: Low V_{CE(sat)}

■ MP-40 Type Transistor

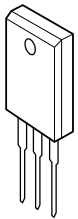

MP-40

V _{CEO} (V) I _{C(DC)} (A)	-40	-60	-80	-100	-150	-200	-250	-300	-400	-800
-3.0		2SB1038 2SD1310								
-4.0				2SD1311						2SC3532
-5.0		{ 2SD1392* 2SC4347*		{ 2SB974 2SD1308 2SC4348					2SC3431 ☆	
-7.0									2SC3158 2SC3432 ☆	
-8.0				{ 2SB975 2SD1309 2SC4349						
-10				{ 2SA1261 2SC3157 2SC4350					2SC3159	

□: Darlington transistor, { : Complementary pair, *: Internal zener diode between C-B, ☆: High speed switching

Quick Reference by Package

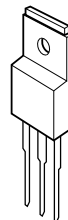

MP-45
(MP-25 Insulated type)



MP-45F
(MP-25 Insulated type)

■ MP-45, MP-45F (TO-220 Insulated Type) Transistor

V _{CEO} (V) I _{C(DC)} (A) Package	~60		~100		~150	~300	~400
	MP-45	MP-45F	MP-45	MP-45F	MP-45	MP-45	MP-45
-2.0			{ 2SA1395 2SC3567		{ 2SB1096 2SD1587		2SC3569
-3.0	{ 2SB1094 2SD1585 2SD1593 ●	2SD2164 ●					
-4.0			2SD1586				
-5.0	{ 2SA1394 2SC3566 2SA1441 ◎ 2SC3691 ◎ 2SC4351* 2SD1595*	{ 2SA1741 ◎ 2SC4549 ◎	{ 2SA1718 2SC4352 2SB1098 2SD1589 2SA1650 ◎ 2SC4334 ◎	{ 2SB1430 2SD2161		2SD1592	2SC3570
-6.0			2SD1594 ●	2SD2165 ●			
-7.0	{ 2SB1097 2SD1588 2SA1442 ◎ 2SC3692 ◎	{ 2SA1742 ◎ 2SC4550 ◎	{ 2SC4062 2SA1651 ◎ 2SC4335 ◎	2SC4553			2SC3571
-8.0			{ 2SA1719 2SD1928 2SB1099 2SD1590	{ 2SA1833 2SB1431 2SD2162			
-10	{ 2SA1443 ◎ 2SC3693 ◎	{ 2SA1743 ◎ 2SC4551 ◎	{ 2SA1396 2SC3568 2SA1652 ◎ 2SC4336 ◎ 2SA1720 2SC4353 2SB1100 2SD1591	{ 2SB1432 2SD2163			2SC3572
-15	{ 2SA1444 ◎ 2SC3694	{ 2SA1744 ◎ 2SC4552 ◎	2SC4063	2SC4554			

□: Darlington transistor, { : Complementary pair, *: Internal zener diode between C-B, ◎: Low V_{CE(sat)}.

●: Single High h_{FE}

Quick Reference by Package

■ MP-80 Type Transistor

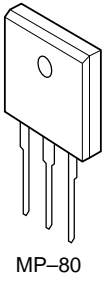

MP-80

V _{CEO} (V) I _{C(DC)} (A)	~80	~100	~120	~130	~140	~160	~250	~400	~800
~2.0							2SD1017		
~5.0		2SC2908					2SD1018		2SC3533 2SC3534
~7.0			{ 2SB849A 2SD1110A 2SB965 2SD1288						2SC3535
~1.0	2SD1070	2SA1141 2SB897 2SD1210	{ 2SB966 2SD1289	{ 2SA1232 2SC3012				2SC2749 2SC3434☆ 2SD1298	2SC3536
~15		2SC2750 2SD1296			{ 2SA1227 2SC2987	{ 2SA1227A 2SC2987A		2SC2751 2SC3435☆	
~25		2SD1297							

□: Darlington transistor, { : Complementary pair, ☆: High speed switching

■ MP-10 Type Transistor

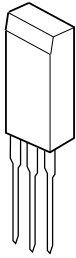

MP-10

V _{CEO} (V) I _{C(DC)} (A)	~60	~100
2.5		2SC4814 ●
~5	{ 2SA1843 ◎ 2SC4815 ◎	{ 2SA1840 2SC4810 2SA1845 ◎ 2SC4817 ◎
~7	{ 2SA1844 ◎ 2SC4816 ◎	{ 2SA1846 ◎ 2SC4818 ◎ 2SC4813 ●
~8		{ 2SA1841 2SC4811
~10		{ 2SA1842 2SC4812 2SA1847 ◎ 2SC4819 ◎

□: Darlington transistor, { : Complementary pair, ●: Low V_{CE}(sat) High h_{FE}, ◎: Low V_{CE}(sat)

Quick Reference by Package



Mini mold
SC-59

■ Mini-Mold Transistor

V _{CEO} (V) I _c (mA)	~15	~20	~30	~40	~50	~60	~80	~120	~200	~300
~10	2SC3663 (8 V, 5 mA)									
~20		2SC2223 2SC2758	2SK160							2SD2383
~30		2SC4568		2SA1226						
~50	2SA1424 (-12 V) 2SA1462 2SC2757 2SC2759 2SC3545 2SC3583 (10 V, 65 mA) 2SC3585 (10 V, 35 mA)	2SC4095 (35 mA)	2SC1009A					2SA811A 2SA1247 2SC1622A 2SC3115	2SC1653 (130 V) 2SC1654 (160 V)	
~100	2SC2351 (70 mA) 2SC3356 (12 V)	2SC4093 2SC4094 (65 mA) 2SC4569 (60 mA)	2SC4092 (25 V, 70 mA) FN2[] (-25 V)		2SA812 2SC1623 FA1[] FN1[]	FA2[]			2SA1330 2SC3360	
~150			2SA1411 (-25 V)		2SC3624 2SC3624A					
~200	2SC3735	2SC1621		2SA1461 2SC3734						
~300						2SB736 2SD780	2SB736A 2SD780A			
~500				2SA1464 2SC3739						
~700			2SB624 (-25 V) 2SD596 (25 V) FB1[] (25 V) FP1[] (-25 V)							
~1000			2SA1467 (-25 V) 2SC3742 (25 V)							

Quick Reference by Package



Power mini mold
SC-62

■ **Power Mini-Mold Transistor**

V_{CE0} (V) / I_C (A)	~20	~25	~50	~60	~80	~100	~120	~140	~300
~50 m								2SA1173 2SC2780	
~200 m	2SC2954 (18 V, 150 mA) 2SC3357 (12 V, 100 mA)								2SC3554
~300 m			2SC3617		2SB800 2SD1001				
~0.7		2SC3618	2SB799 2SD1000			2SB805 2SD1006	2SB806 2SD1007		
~1.0		2SB798 2SD999	2SA1463 2SB1115 2SC3736 2SD1615 2SD1702	2SB1115A 2SD1615A HD1[] HD2[] HR1[]	2SB804 2SD1005 2SD1699				
~2.0	2SB1114 2SD1614 HC1[] HQ1[]	2SD1950 2SJ179 (30 V, 1.5 A)							
~3.0	2SB1301 HC2[] (16 V) HQ2[] (-16 V)			2SB1572 2SD2403					
~5.0			2SB1571 2SD2402						

: Darlington connection



MP-2

■ **MP-2 Type Transistor**

V_{CE0} (V) / I_C (A)	~20	~60	~100	~400	~600
~1.0					2SA1871 2SC4942
~3.0	2SB1581				
~5.0		2SB1578 2SD2425			

Quick Reference by Package

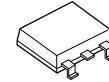

MP-3

■ **MP-3 Type (SC-63) Transistor**

V_{CE0} (V) / I_c (A)	~20	~30	~45	~60	~100	~200	~300	~400	~600
~0.2							2SC2802		
~0.5								2SA1400-Z 2SC3588-Z	
~1.0				2SB963-Z 2SD1286-Z					2SA1413-Z 2SC3632-Z
~2.0	2SD1583-Z	2SD992-Z		2SD1164-Z (1.5 A)		2SB768 (150 V) 2SD1033 (150 V) 2SC2946(1)		2SA1412-Z 2SC3631-Z	
~3.0		2SB962-Z	2SD1448-Z	2SB1261-Z 2SD1584-Z 2SD1899-Z					
~5.0				2SA1385-Z 2SC3518-Z					
~10	2SA1615-Z								

 : Darlington connection



Small mini mold

■ **Small Mini-Mold Transistor**

V_{CE0} (V) / I_c (mA)	~15	~20	~30	~40	~50	~120	~160
~10							
~20		2SC4178					
~30							
~50	2SA1610		2SC4179			2SA1612 2SC4180	2SA1609
~100					2SA1611 2SC4177 GA1[] GN1[]		
~150		2SA1613 (25 V)			2SC4181		
~200	2SC4176	2SC4175					
~500			2SB1475 (-25 V) 2SD2228 (25 V)	2SA1608 2SC4173			

■ **Ultra Small Mini-Mold Transistor**

V_{CE0} (V) / I_c (mA)	~50
~100	2SA1836 2SC4783



Ultra small mini mold

Quick Reference Table by Function/Application

■ **Small Signal Transistor (1/2)**

	TO-92	SP-8	SST	SMALL MINI MOLD	MINI MOLD	POWER MINI
FM/FM RF	2SA1005				2SA1226	
RF/MIX/CON	2SC1674		2SC2786	2SC4178	2SC2223	
FM AM/FM/AM MIX/OSC/IF	2SC1675		2SC2787	2SC4179	2SC1009A	
Audio Frequency Amplification	2SA733		2SA1175	2SA1611	2SA812	
	2SA987				(2SA812)	
	2SA988			2SA1612	2SA811A	
	2SA1409		2SA1410	2SA1613	2SA1411	
	2SC945		2SC2785	2SC4177	2SC1623	
	2SC945 (L)				(2SC1623)	
	2SC1840				(2SC1623)	
	2SC1841				2SC1622A	
Low Noise Amplification	2SC3622/A		2SC3623/A	2SC4181	2SC3624/A	
	2SA990					
	2SA991					
	2SA992		2SA1174		2SA1247	
	2SC1842					
	2SC1843					
	2SC1844					
2SC1845		2SC2784		2SC3115		
	2SA1138					
Driver Output	2SA952		2SB810		2SB624	
	2SA953				2SB736	
	2SA954				2SB736A	2SB800
	2SA1376				2SA1330	
		2SA915				2SA1173
		2SA916		2SA1609		
		2SB564	2SB811			2SB798
		2SB605				2SB799
		2SB733				
		2SB734				
	2SB1068					2SB1114
	2SB1116					2SB1115
	2SB1116A					2SB1115A
						2SB804
						2SB805
						2SB806
	2SC2001		2SD1020		2SD596	
2SC2002				2SD780		
2SC2003				2SD780A	2SD1001	
2SC3478				2SC3360		

Quick Reference Table by Function/Application
--

■ Small Signal Transistor (2/2)

	TO-92	SP-8	SST	SMALL MINI MOLD	MINI MOLD	POWER MINI
Driver Output		2SC1940			2SC1653	2SC2780
		2SC1941			2SC1654	
		2SC3209				2SC3554
	2SC3615					2SC3617
	2SC3616					2SC3618
		2SD471				2SD999
		2SD571				2SD1000
		2SD773				
		2SD774				
	2SD1513					2SD1614
	2SD1616					2SD1615
	2SD1616A					2SD1615A
						2SD1005
						2SD1006
						2SD1007
	2SD1698	2SD1697				2SD1699
	2SD1701	2SD1700				2SD1702
	2SD1581				2SD1950	
Switching	2SA1206		2SA1459	2SA1610	2SA1462	
	2SA1153			2SA1608	2SA1464	
		2SA1460				2SA1463
			2SA1458		2SA1461	
	2SC2720			2SC4173	2SC3739	
	2SC2901		2SC3732	2SC4176	2SC3735	
		2SC3733				2SC3736
			2SC3731		2SC3734	

Quick Reference Table by Function/Application

Power Transistor

■ **Low $V_{CE(sat)}$ Transistor**

Charac- teristics $V_{CE0}, I_{C(DC)}$	SP-8	MP-2	MP-3	MP-5 (TO-126)	MP-25	MP-10	MP-45	MP-45F
16 V, 3 A		2SB1581						
20 V, 5 A				2SD741				
20 V, 10 A	2SA1897 (5A)		2SA1615					
25 V, 3 A	2SB1117							
30 V, 3 A			2SB962	2SB772 2SD882				
30 V, 10 A			2SA1649 2SC4333					
60 V, 3A			2SB1261 2SD1899	2SB1217 2SD1818				
60 V, 5 A		2SB1578 2SD2425	2SA1385 2SC3518	2SB1151 2SD1691		2SA1843 2SC4815		
			2SA1648 2SC4332				2SA1441 2SC3691	2SA1741 2SC4549
60 V, 7 A			2SC4344			2SA1844 2SC4816	2SA1442 2SC3692	2SA1742 2SC4550
60 V, 10 A							2SA1443 2SC3693	2SA1743 2SC4551
60 V, 15 A							2SA1444 2SC3694	2SA1744 2SC4552
100 V, 5 A			2SA1647 2SC4331		2SA1644 2SC4328	2SA1845 2SC4817	2SA1650 2SC4334	
100 V, 7 A			2SC4343		2SA1645 2SC4329	2SA1846 2SC4818	2SA1651 2SC4335	
100 V, 10 A					2SA1646 2SC4330	2SA1847 2SC4819	2SA1652 2SC4336	

■ **High h_{FE} Transistor**

Charac- teristics $V_{CE0}, I_{C(DC)}$	SP-8	MP-3	MP-5 (TO-126)	MP-10	MP-45	MP-45F
20 V, 2 A		2SD1583				
25 V, 2 A	2SD1581					
50 V, 1 A	2SD1582					
60 V, 3 A		2SD1584	2SD1694		2SD1593	2SD2164
100 V, 2.5 A				2SC4814*		
100 V, 6 A					2SD1594	2SD2165
100 V, 7.5 A				2SC4813*	2SC4062	2SC4553*
100 V, 15 A					2SC4063	2SC4554*

*: Low $V_{CE(sat)}$ & High h_{FE}

Quick Reference Table by Function/Application

■ **Low Voltage, High Speed Switching Transistor**

Characteristics V _{CEO} , I _{C(DC)}	SP-8	MP-25	MP-45	MP-80
45 V, 1 A	(2SA1460 2SC3733			
60 V, 5 A		(2SA1069 2SC2516	(2SA1394 2SC3566	
100 V, 2 A		(2SA1008 2SC2331	(2SA1395 2SC3567	
100 V, 5 A		2SC2517		
100 V, 7 A		(2SA1010 2SC2334		
100 V, 7.5A		2SC2373		
100 V, 10 A			(2SA1396 2SC3568	
100 V, 15 A				2SC2750

■ **High Voltage, High Speed Switching Transistor**

Characteristics V _{CEO} , I _{C(DC)}	MP-3	MP-5 (TO-126)	MP-25 (TO-220)	MP-40	MP-45	MP-80
200 V, 2 A	2SC2885 2SC2946 2SC2946(1)					
350 V, 2 A			2SA1009			
400 V, 0.5 A	(2SA1400 2SC3588	(2SA1156 2SC2752				
400 V, 2 A	(2SC3631		2SA1009A 2SC2333		2SC3569	
400 V, 5 A			2SC2518		2SC3570	
400 V, 7 A			2SC2335	2SC3158	2SC3571	
400 V, 10 A				2SC3159	2SC3572	2SC2749
400 V, 15 A						2SC2571
600 V, 2 A	(2SA1413 2SC3632	(2SA1486 2SC3840				

■ **800 V, High Speed Switching Transistor**
(t_r = 0.5 μs MAX.)

Characteristics V _{CEO} , I _{C(DC)}	MP-25 (TO-220)	MP-40	MP-80
800 V, 3 A	2SC3531		2SC3533
800 V, 4 A		2SC3532	2SC3534
800 V, 6 A			2SC3535
800 V, 10 A			2SC3536

■ **High Voltage, High Speed Switching Transistor**
(t_r = 0.3 μs MAX.)

Characteristics V _{CEO} , I _{C(DC)}	MP-3	MP-40	MP-80
400 V, 5 A	2SC4346	2SC3431	
400 V, 7 A		2SC3432	
400 V, 10 A			2SC3434
400 V, 15 A			2SC3435

Quick Reference Table by Function/Application

■ **Audio Frequency Amplification Transistor**

Characteristics V _{CE0} , I _{C(DC)}	MP-3	MP-5 (TO-126)	MP-25 (TO-220)	MP-40	MP-45	MP-80	MP-85
30 V, 2 A	2SD992						
45 V, 3 A	2SD1448	{ 2SB744 2SD794	2SD795				
50 V, 1 A		{ 2SB731 2SD809(1)					
60 V, 3 A		{ 2SB744A 2SD794A	{ 2SB1089 2SD1567 2SD288 2SD289	{ 2SB1038 2SD1310	{ 2SB1094 2SD1585		
60 V, 7 A			{ 2SB707 2SD568		{ 2SB1097 2SD1588		
60 V, 10 A						2SD1070	
80 V, 0.8 A		2SB548 2SD414					
80 V, 4 A			{ 2SB703 2SD743				
80 V, 7 A			{ 2SB708 2SD569				
100 V, 0.8 A		{ 2SB549 2SD415					
100 V, 4 A			{ 2SB703A 2SD743A 2SD1568	2SD1311	2SD1586		
120 V, 1.5 A			{ 2SB536 2SB537 2SD381 2SD382				
120 V, 7 A						{ 2SB849A 2SD1110A 2SB965 2SD1288	
120 V, 8 A						{ 2SB966 2SD1289	{ 2SB1315 2SD1977
150 V, 2 A	{ 2SB768 2SD1033 2SD1557		{ 2SB546A 2SB547A 2SD401A 2SD402A		{ 2SB1096 2SD1587		
250 V, 2 A						2SD1017	
250 V, 4 A						2SD1018	

Quick Reference Table by Function/Application
--

■ High Frequency Amplification Transistor

Characteristics V_{CE0} , $I_{C(DC)}$	SP-8	MP-3	MP-5 (TO-126)	MP-25 (TO-220)	MP-80
35 V, 2 A			2SC1449		
40 V, 7 A				{ 2SA1129 2SC2654	
120 V, 1.2 A			{ 2SA1220 2SC2690		
120 V, 1.5 A				{ 2SA985 2SC2275	
130 V, 10 A					{ 2SA1232 2SC3012
140 V, 12 A					{ 2SA1227 2SC2987
150 V, 1.5 A				{ 2SA985A 2SC2275A	
160 V, 1.2 A			{ 2SA1220A 2SC2690A		
160 V, 12 A					{ 2SA1227A 2SC2987A
180 V, 1.5 A				{ 2SA1006 2SC2336	
200 V, 1.5 A				{ 2SA1006A 2SC2336A	
250 V, 0.1 A	2SC4000		{ 2SA1546 2SC4001		
250 V, 1.5 A				2SA1006B 2SC2336B	
300 V, 0.1 A			2SC2371		
300 V, 0.2 A	2SC3209	2SC2802	2SC2688		
				2SC1505 2SC1506 2SC1507	

Quick Reference Table by Function/Application

■ **Darlington Transistor**

Charac- teristics V _{CEO} , I _{C(DC)}	SP-8	MP-3	MP-5 (TO-126)	MP-25 (TO-220)	MP-10	MP-40	MP-45	MP-45F	MP-80
31 V, 2 A	2SD2463*		2SD1695*						
60 V, 0.8 A	2SD1700*								
60 V, 1 A	2SD1843	{ 2SB963 2SD1286 2SC4337◎	2SD1630* 2SC4340◎						
60 V, 1.5 A		2SD1164	{ 2SB794 2SD985 2SB1111* 2SD1491*						
60 V, 3 A			{ 2SB1150* 2SD1693*						
60 V, 5 A				2SD1564*		2SD1392* 2SC4347◎*	2SD1595* 2SC4351◎		
80 V, 0.8 A	2SD1697								
80 V, 1.5 A	{ 2SB1093 2SD1579		{ 2SB795 2SD986						
80 V, 2 A		2SC4338◎	2SC4341						
100 V, 3 A		2SC4339	{ 2SB1149 2SD1692 2SA1714◎ 2SC4342◎						
100 V, 5 A		2SC4345		{ 2SB601 2SD560	{ 2SA1840 2SC4810	{ 2SA1715◎ 2SC4348◎	{ 2SA1718◎ 2SC4352◎		
				{ 2SB1087 2SD1565		{ 2SB974 2SD1308	{ 2SB1098 2SD1589	{ 2SB1430 2SD2161	
100 V, 8 A					{ 2SA1841 2SC4811	2SA1716◎ 2SC4349◎	{ 2SA1719◎ 2SD1928◎	{ 2SB1431 2SD2162 2SA1833◎	
100 V, 10 A					{ 2SA1842 2SC4812	{ 2SA1717◎ 2SC4350◎	{ 2SA1720◎ 2SC4353◎ 2SB1100 2SD1591	{ 2SB1432 2SD2163	{ 2SB897 2SD1210
100 V, 15 A									2SD1296
100 V, 25 A									2SD1297
300 V, 5 A				2SD1162			2SD1592		
400 V, 5 A				2SD987					
400 V, 10 A									2SD1298

◎: High speed darlington transistor, *: Internal zener diode between C-B

Field Effect Transistor

Small Signal FET

■ 2SK type (Junction type)

Type number	Package	Absolute maximum ratings ($T_A = 25\text{ }^\circ\text{C}$)			Electrical characteristics ($T_A = 25\text{ }^\circ\text{C}$)		Applications
		V _{GDO} (V)	I _D (mA)	P _T (mW)	Y _{fs1} (ms)	I _{DSS} (mA)	
2SK104	TO-92	30	20	250	2.5 ^{TYP.}	2.5 ^{TYP.}	HF amplification
2SK105	TO-92	50	20	250	2.1	2.5	AF amplification
2SK162	TO-92	40	50	400	45	18	AF low noise amplification
2SK163	TO-92	50	30	400	9.0	8.0	AF low noise amplification
2SK193	SST	20	10	250	3.5	2.5	FM tuner
2SK195	TO-92	20	10	250	3.5	2.5	FM tuner
2SK505	TO-92	15	50	400	19	20	Video band RF amplification
2SK507	SST	15	50	350	19	20	Video band RF amplification
2SK514	SST	50	20	250	1.8	3.5	AF amplification
2SK518	TO-92	30	50	400	17	60	HF amplification
2SK519	SST	30	50	350	17	60	HF amplification
2SK523	TO-92	50	30	400	9.0	8.0	AF low noise amplification
2SK533	TO-92	50	30	400	9.0	8.0	AF low noise amplification
2SK660	SST	20	10	100	150 (MAX.)	0.5 (MAX.)	ECM impedance conversion
2SK997	SST	20	10	100	0.27	0.5 (MAX.)	ECM impedance conversion
2SK998	TO-92	20	35	350	16	20	HF amplification
2SK1000	SST	22*	50	250	28	20	AM tuner, HF amplification
2SK1109	Mini mold	20	10	80	0.48	0.6 (MAX.)	ECM impedance conversion

*: V_{GSD}

■ 2SK type (MOS type) (1/2)

Type number	Package	Absolute maximum rating ($T_A = 25\text{ }^\circ\text{C}$)				Electrical characteristics ($T_A = 25\text{ }^\circ\text{C}$)							Applications
		V _{DSS} (V)	I _D		P _T (W)	y _{fs} (S)			R _{DS(on)} (Ω)				
			DC (A)	Pulse (A)		V _{DS} (V)	I _D (A)	MIN.	V _{GS} (V)	I _D (A)	TYP.	MAX.	
2SK679A	TO-92	30	±0.5	±1.5	0.75	10	0.5	0.4	4	0.5	0.6	1.0	Switching
2SK680A	SC-62	30	±1.0	±2.0	1.0	10	0.5	0.4	4	0.5	0.6	1.0	
2SK681A	SP-8	30	±1.0	±2.0	1.0	10	0.5	0.4	4	0.5	0.6	1.0	
2SK1132	SST	50	0.1	0.2	0.25	5	0.02	0.03	4	0.02	30	50	
2SK1133	SC-59	50	0.1	0.2	0.2	5	0.02	0.03	4	0.02	30	50	
2SK1272	TO-92	60	±1.0	±2.0	0.75	10	0.5	0.4	4	0.5	—	1.0	
2SK1273	SC-62	60	±2.0	±4.0	2.0	10	0.5	0.4	4	0.5	—	1.0	

Field Effect Transistor

■ **2SK type (MOS type) (2/2)**

Type number	Package	Absolute maximum rating (T _A = 25 °C)				Electrical characteristics (T _A = 25 °C)								Applications
		V _{DSS} (V)	I _D		P _T (W)	y _f s (S)			R _{DS(on)} (Ω)					
			DC (A)	Pulse (A)		V _{DS} (V)	I _D (A)	MIN.	V _{GS} (V)	I _D (A)	TYP.	MAX.		
2SK1274	SP-8	60	±1.5	±3.0	1.0	10	0.5	0.4	4	0.5	—	1.0	Switching	
2SK1398	SST	50	0.1	0.2	0.25	3	0.01	0.02	2.5	0.005	20	40		
2SK1399	SC-59	50	0.1	0.2	0.2	3	0.01	0.02	2.5	0.005	20	40		
2SK1482	TO-92	30	±1.5	±3.0	0.75	10	0.5	0.4	4	0.5	0.19	0.8		
2SK1483	SC-62	30	±2.0	±4.0	2.0	10	0.5	0.4	4	0.5	0.19	0.8		
2SK1484	TO-92	100	±0.5	±1.0	0.75	10	0.5	0.4	4	0.5	0.62	1.2		
2SK1485	SC-62	100	±1.0	±2.0	2.0	10	0.5	0.4	4	0.5	0.62	1.2		
2SK1580	SC-70	16	0.1	0.2	0.15	3	0.01	0.02	2.5	0.001	9	15		
2SK1581	SC-59	16	0.2	0.4	0.2	3	0.01	0.02	2.5	0.001	3.2	5		
2SK1582	SC-59	30	0.2	0.4	0.2	5	0.01	0.02	4	0.01	2.2	5		
2SK1583	SC-62	16	±0.5	±1.0	2.0	5	0.3	0.4	2.5	0.3	1.2	2.0		
2SK1584	SC-62	30	±0.5	±1.0	2.0	5	0.3	0.4	2.5	0.3	1.2	2.0		
2SK1585	SC-62	16	±1.0	±2.0	2.0	5	0.5	0.4	2.5	0.5	0.8	1.2		
2SK1586	SC-62	30	±1.0	±2.0	2.0	5	0.5	0.4	4	0.5	—	1.0		
2SK1587	SC-62	16	±2.0	±4.0	2.0	5	1.0	0.4	2.5	1.0	0.55	0.8		
2SK1588	SC-62	16	±3.0	±6.0	2.0	3	1.0	0.4	2.5	1.0	0.34	0.5		
2SK1589	SC-59	100	0.1	0.2	0.2	5	0.01	0.02	4	0.01	19	30		
2SK1590	SC-59	60	0.2	0.4	0.2	5	0.01	0.02	4	0.01	3.2	6		
2SK1591	SC-59	100	0.2	0.4	0.2	5	0.01	0.02	4	0.01	5.8	8		
2SK1592	SC-62	60	±0.5	±1.0	2.0	10	0.5	0.4	4	0.5	1.6	2.5		
2SK1593	SC-62	100	±0.5	±1.0	2.0	10	0.5	0.4	4	0.5	4.0	6.0		
2SK1824	3-pin ultra super mini	30	0.1	0.2	0.2	3	0.01	0.02	2.5	0.001	7	13		
2SK1958	SC-70	16	0.1	0.2	0.15	3	0.01	0.02	1.5	0.001	30	50		
2SK1959	SC-62	16	±2.0	±4.0	2.0	3	1.0	1.0	1.5	0.05	0.08	0.8		
2SK1960	SC-62	16	±3.0	±6.0	2.0	3	1.5	2.0	1.5	0.1	0.35	0.8		
2SK2053	MP-2	16	±5	±10	2.0	3	2.5	0.4	1.5	0.5	0.2	0.4		
2SK2054	MP-2	60	±3	±6	2.0	10	1.5	2.0	4	1.5	0.18	0.25		
2SK2055	MP-2	100	±2	±4	2.0	10	1.0	2.0	4	1.0	0.28	0.45		
2SK2070	SP-8	100	±1	±2	2.0	10	1.0	2.0	4	1.0	0.28	0.45		
2SK2090	SC-70	50	±0.1	±0.2	0.15	3	0.01	0.02	2.5	0.01	20	40		
2SK2109	SC-62	60	±0.5	±1.0	2.0	10	0.3	0.4	4	0.3	0.55	1.5		
2SK2110	SC-62	100	±0.5	±1.0	2.0	10	0.3	0.4	4	0.3	0.90	2.0		
2SK2111	SC-62	60	±1.0	±2.0	2.0	10	0.5	0.4	4	0.5	0.35	1.0		
2SK2112	SC-62	100	±1.0	±2.0	2.0	10	0.5	0.4	4	0.5	0.67	1.5		
2SK2157	MP-2	30	±5	±10	2.0	10	2.5	2.0	4	2.5	0.08	0.15		
2SK2158	SC-59	50	0.1	0.2	0.2	3	0.01	0.02	1.5	0.001	21	50		
2SK2159	SC-62	60	±2	±4	2.0	10	1.0	0.4	1.5	0.1	0.26	0.7		
2SK2541	SST	50	±0.1	±0.2	0.2	3	0.01	0.02	1.5	0.001	21	50		

Field Effect Transistor

■ **2SJ type (Junction type)**

Type number	Package	Absolute maximum ratings (T _A = 25 fC)			Electrical characteristics (T _A = 25 fC)		Applications
		V _{GDO} (V)	I _D (mA)	P _T (mW)	Y _{fs1} (mS)	I _{DSS} (mA)	
2SJ44	TO-92	40	30	400	9.0 TYP.	9.0 TYP.	AF low noise amplification
2SJ45	TO-92	40	30	400	9.0	9.0	AF amplification

■ **2SJ type (MOS type)**

Type number	Package	Absolute maximum rating (T _A = 25 fC)				Electrical characteristics (T _A = 25 fC)							Applications
		V _{DSS} (V)	I _D		P _T T _C = 25 °C (W)	y _{fs} (S)			R _{DS(on)} (Ω)				
			DC (A)	Pulse (A)		V _{DS} (V)	I _D (A)	MIN.	V _{GS} (V)	I _D (A)	TYP.	MAX.	
2SJ165	SST	-50	±0.1	±0.2	0.25	-5	-0.02	0.03	-4	-0.02	22	50	Switching
2SJ166	SC-59	-50	±0.1	±0.2	0.2	-5	-0.02	0.03	-4	-0.02	22	50	
2SJ178	TO-92	-30	±1.0	±2.0	0.75	-10	-0.5	0.4	-4	-0.5	—	1.5	
2SJ179	SC-62	-30	±1.5	±3.0	2.0	-10	-0.5	0.4	-4	-0.5	—	1.5	
2SJ180	SP-8	-30	±1.0	±2.0	1.0	-10	-0.5	0.4	-4	-0.5	—	1.5	
2SJ184	SST	-50	±0.1	±0.2	0.25	-5	-0.02	0.02	-2.5	-0.05	25	40	
2SJ185	SC-59	-50	±0.1	±0.2	0.2	-5	-0.02	0.02	-2.5	-0.05	25	40	
2SJ196	TO-92	-60	±1.0	±2.0	0.75	-10	-0.5	0.4	-4	-0.5	0.89	1.5	
2SJ197	SC-62	-60	±1.5	±3.0	2.0	-10	-0.5	0.4	-4	-0.5	0.89	1.5	
2SJ198	TO-92	-100	±0.5	±1.0	0.75	-10	-0.5	0.4	-4	-0.5	1.7	2.0	
2SJ199	SC-62	-100	±1.0	±2.0	2.0	-10	-0.5	0.4	-4	-0.5	1.7	2.0	
2SJ202	SC-70	-16	±0.1	±0.2	0.15	-3	-0.01	0.02	-2.5	-0.001	—	60	
2SJ203	SC-59	-16	±0.2	±0.4	0.2	-3	-0.01	0.02	-2.5	-0.001	16	20	
2SJ204	SC-59	-30	±0.2	±0.4	0.2	-3	-0.01	0.02	-2.5	-0.001	8.8	15	
2SJ205	SC-62	-16	±0.5	±1.0	2.0	-5	-0.3	0.4	-2.5	-0.3	2.2	5.0	
2SJ206	SC-62	-30	±0.5	±1.0	2.0	-5	-0.3	0.4	-2.5	-0.3	2.8	3.0	
2SJ207	SC-62	-16	±1.0	±2.0	2.0	-5	-0.5	0.4	-2.5	-0.5	1.5	2.0	
2SJ208	SC-62	-16	±2.0	±4.0	2.0	-5	-1.0	0.4	-2.5	-1.0	0.6	1.5	
2SJ209	SC-59	-100	±0.1	±0.2	0.2	-5	-0.01	0.02	-4	-0.01	60	100	
2SJ210	SC-59	-60	±0.2	±0.4	0.2	-5	-0.01	0.02	-4	-0.01	10	15	
2SJ211	SC-59	-100	±0.2	±0.4	0.2	-5	-0.01	0.02	-4	-0.01	18	30	
2SJ212	SC-62	-60	±0.5	±1.0	2.0	-10	-0.5	0.4	-4	-0.5	1.8	4.0	
2SJ218	SC-62	-100	±0.5	±1.0	2.0	-10	-0.5	0.4	-4	-0.5	2.7	5.0	
2SJ243	3-pin ultra super mini	-30	±0.1	±0.2	0.2	-3	-0.01	0.02	-2.5	-0.0005	55	100	
2SJ353	SP-8	-60	±1.5	±3.0	1.0	-10	-1	1.0	-4	-0.8	0.58	0.68	
2SJ411	SP-8	-30	±5	±20	1.0	-10	-2.5	3.0	-4	-2.5	0.096	0.24	
2SJ460	SST	-50	±0.1	±0.2	0.25	-3	-0.01	0.01	-2.5	-0.003	75	100	
2SJ461	SC-59	-50	±0.1	±0.2	0.2	-3	-0.01	0.01	-2.5	-0.003	75	100	
2SJ462	MP-2	-12	±2.5	±5.0	2.0	-3	-1	1.5	-2.5	-0.5	0.23	0.3	
2SJ463	SC-70	-30	±0.1	±0.2	0.15	-3	-0.01	0.02	-2.5	-0.001	30	60	

Field Effect Transistor

Power MOS FET

■ **2SK type (1/5)**

Type number	Package	Absolute maximum rating (T _A = 25 °C)				Electrical characteristics (T _A = 25 °C)							Applications
		V _{DSS} (V)	I _D		P _T T _C = 25 °C (W)	y _{fs} (s)			R _{DS(on)} (Ω)				
			DC (A)	Pulse (A)		V _{DS} (V)	I _D (A)	MIN.	V _{GS} (V)	I _D (A)	TYP.	MAX.	
2SK459	MP-25	200	±10	±15	60	10	3	1	10	3	0.35	0.5	Switching
2SK591	MP-45	60	±15	±60	35	10	6	5	4	6	0.05	0.07	
2SK611	MP-3	100	±1	±3	10	10	0.5	0.2	4	0.2	5.0	6.0	
2SK612	MP-3	100	±2	±8	10	10	1	1	4	0.8	0.35	0.6	
2SK654	MP-3	100	±1	±3	10	10	0.5	0.5	4	0.2	1.7	4.0	
2SK659	MP-45	60	±12	±60	35	10	6	5	4	6	0.08	0.095	
2SK699	MP-5	100	±2.0	±6.0	15	10	1	0.5	4	1	1.0	1.5	
2SK700	MP-5	80	±2	±6	15	10	1	0.5	4	1	0.8	1.0	
2SK701	MP-5	60	±2	±6	15	10	1	0.5	4	1	0.6	0.85	
2SK702	MP-25	100	±5	±20	50	10	3	5	4	5	0.25	0.5	
2SK703	MP-45	100	±5	±20	35	10	3	5	4	5	0.25	0.5	
2SK704	MP-25	60	±5	±20	50	10	3	5	4	5	0.17	0.3	
2SK705	MP-45	60	±5	±20	35	10	3	5	4	5	0.17	0.3	
2SK707	MP-80	250	±25	±100	120	10	13	5	10	13	0.14	0.18	
2SK719	MP-80	900	±5	±10	120	20	3	1	10	3	3.2	4.0	
2SK720A	MP-80	250	±20	±80	120	10	10	5	10	10	0.18	0.23	
2SK735	MP-88	450	±10	±30	120	10	5	3	10	5	0.6	0.8	
2SK736	MP-45	100	±15	±60	35	10	6	5	4	6	0.055	0.10	
2SK737	MP-45	100	±12	±60	35	10	6	5	4	6	0.08	0.20	
2SK738	MP-3	30	±2	±8	20	10	1	1	4	0.8	0.13	0.25	
2SK739	MP-3	60	±2	±8	20	10	1	1	4	0.8	0.25	0.35	
2SK773	MP-80	500	±12	±40	120	10	6	5	10	6	0.47	0.6	
2SK774	MP-80	500	±18	±60	120	10	9	8	10	9	0.35	0.45	
2SK784	MP-88	450	±20	±80	150	10	10	9	10	10	0.25	0.35	
2SK785	MP-88	500	±20	±80	150	10	10	9	10	10	0.3	0.4	
2SK786	MP-25	900	±3	±6	50	20	1.5	0.8	10	1.5	6.0	7.5	
2SK787	MP-88	900	±8	±16	150	10	4	1	10	4	1.25	1.6	
2SK797	MP-88	60	±40	±120	150	10	6	5	4	20	—	0.025	
2SK798	MP-88	100	±40	±120	150	10	6	5	4	20	—	0.04	
2SK799	MP-80	450	±12	±40	120	10	6	5	10	6	0.4	0.5	
2SK800	MP-80	450	±18	±60	120	10	9	8	10	9	0.32	0.38	
2SK801	MP-3	30	±2	±8	12	10	1	1	4	1	0.3	0.5	
2SK802	MP-5	30	±2	±8	15	10	1	1	4	1	0.3	0.5	
2SK810	MP-25	100	±14	±56	60	10	8	4	4	8	0.15	0.25	
2SK811	MP-45	100	±12	±48	35	10	8	4	4	8	0.15	0.25	
2SK812	MP-25	60	±27	±108	60	10	15	6	4	15	0.1	0.15	
2SK813	MP-45	60	±21	±84	35	10	15	6	4	15	0.1	0.15	
2SK814	MP-45	30	±15	±60	35	10	8.0	6	4	8.0	0.07	0.1	

Field Effect Transistor

■ 2SK type (2/5)

Type number	Package	Absolute maximum rating (T _A = 25 °C)				Electrical characteristics (T _A = 25 °C)							Applications
		V _{DSS} (V)	I _D		P _T T _C = 25 °C (W)	y _{fs} (S)			R _{DS(on)} (Ω)				
			DC (A)	Pulse (A)		V _{DS} (V)	I _D (A)	MIN.	V _{GS} (V)	I _D (A)	TYP.	MAX.	
2SK815	MP-45	100	±21	±84	35	10	15	6	4	15	0.09	0.15	
2SK817	MP-45	60	±26	±104	35	10	15	8	4	15	0.06	0.08	
2SK819	MP-88	500	±10	±30	120	10	5.0	3	10	5.0	0.7	1.0	
2SK820	MP-85	250	±18	±72	80	10	10	5	10	10	0.18	0.23	
2SK821	MP-88	250	±20	±80	150	10	10	5	10	10	0.18	0.23	
2SK822	MP-85	250	±22	±88	90	10	13	5	10	13	0.12	0.15	
2SK823	MP-88	250	±25	±100	150	10	13	5	10	13	0.12	0.15	
2SK824	MP-85	450	±12	±40	90	10	7.5	5	10	7.5	0.4	0.5	
2SK825	MP-88	450	±15	±40	150	10	7.5	5	10	7.5	0.4	0.5	
2SK826	MP-85	450	±15	±60	95	10	9.0	8	10	9.0	0.32	0.38	
2SK827	MP-88	450	±18	±60	150	10	9.0	8	10	9.0	0.32	0.38	
2SK828	MP-85	500	±12	±40	90	10	7.5	5	10	7.5	0.47	0.6	
2SK829	MP-88	500	±15	±40	150	10	7.5	5	10	7.5	0.47	0.6	
2SK830	MP-85	500	±15	±60	95	10	9.0	8	10	9.0	0.35	0.45	
2SK831	MP-88	500	±18	±60	150	10	9.0	8	10	9.0	0.35	0.45	
2SK832	MP-85	900	±4	±10	85	10	3.0	1	10	3.0	3.2	4.0	
2SK833	MP-88	900	±5	±10	150	20	3.0	1	10	3.0	3.2	4.0	
2SK854	MP-25	450	±5	±20	50	10	2.5	2.5	10	2.5	1.0	1.4	
2SK855	MP-25	500	±5	±20	50	10	2.5	2.5	10	2.5	1.2	1.5	
2SK871	MP-88	900	±4	±8	120	10	2.0	1	10	2.0	4.0	5.5	
2SK872	MP-88	900	±6	±12	150	10	3.0	2	10	3.0	1.7	2.5	
2SK873	MP-88	450	±8	±32	100	10	4.0	3	10	4.0	0.8	1.1	
2SK874	MP-88	500	±8	±32	100	10	4.0	3	10	4.0	0.9	1.2	
2SK875	MP-88	450	±12	±48	120	10	6.0	5	10	6.0	0.5	0.6	
2SK876	MP-88	500	±12	±48	120	10	6.0	5	10	6.0	0.6	0.7	
2SK926	MP-25	250	±10	±40	60	10	5.0	2.5	10	5.0	0.4	0.5	
2SK928	MP-45	450	±5	±10	40	10	2.5	2.5	10	2.5	1.0	1.4	
2SK929	MP-45	500	±5	±10	40	10	2.5	2.5	10	2.5	1.2	1.5	
2SK946	MP-45	900	±3	±8	40	10	2.0	1	10	2.0	4.0	5.5	
2SK991	MP-25	100	±4	±8	35	10	2.0	1	4	2.0	0.5	0.7	
2SK992	MP-45	100	±4	±8	30	10	2.0	1	4	2.0	0.5	0.7	
2SK993	MP-25	60	±8	±16	35	10	4.0	1.5	4	4.0	0.3	0.4	
2SK994	MP-45	60	±7	±14	30	10	4.0	1.5	4	4.0	0.3	0.4	
2SK1059	MP-3	60	±5	±20	20	10	3.0	4	4	3.0	0.15	0.22	
2SK1060	MP-3	100	±5	±20	20	10	3.0	4	4	3.0	0.22	0.38	
2SK1122	MP-88	100	±40	±160	100	10	20	12	4	20	0.05	0.07	
2SK1123	MP-88	60	±40	±160	100	10	20	12	4	20	0.03	0.05	
2SK1149	MP-85	100	±40	±160	75	10	20	12	4	20	0.05	0.07	
2SK1150	MP-85	60	±40	±160	75	10	20	12	4	20	0.03	0.05	
2SK1198	MP-45	700	±2	±8	35	10	1.0	1	10	1.0	2.5	3.2	

Field Effect Transistor

■ 2SK type (3/5)

Type number	Package	Absolute maximum rating (T _A = 25 °C)				Electrical characteristics (T _A = 25 °C)							Applications
		V _{DSS} (V)	I _D		P _T T _C = 25 °C (W)	y _{fs} (S)			R _{DS(on)} (Ω)				
			DC (A)	Pulse (A)		V _{DS} (V)	I _D (A)	MIN.	V _{GS} (V)	I _D (A)	TYP.	MAX.	
2SK1271	MP-88	1400	±5	±10	150	20	3.0	1.5	10	3.0	3.5	4.0	Switching
2SK1281	MP-88	700	±4	±8	120	10	2.0	1.0	10	2.0	2.5	3.2	
2SK1282	MP-3	60	±3	±12	20	10	2.0	2.4	4	2.0	0.2	0.3	
2SK1283	MP-5	60	±3	±12	20	10	2.0	2.4	4	2.0	0.2	0.3	
2SK1284	MP-3	100	±3	±12	20	10	2.0	2.4	4	2.0	0.32	0.45	
2SK1285	MP-5	100	±3	±12	20	10	2.0	2.4	4	2.0	0.32	0.45	
2SK1286	MP-45F	60	±15	±60	35	10	8.0	7	4	8.0	0.075	0.095	
2SK1287	MP-25	60	±20	±80	60	10	8.0	7	4	8.0	0.075	0.095	
2SK1288	MP-45F	100	±15	±60	35	10	8.0	7	4	8.0	0.12	0.14	
2SK1289	MP-25	100	±20	±80	60	10	8.0	7	4	8.0	0.12	0.14	
2SK1290	MP-45F	60	±25	±100	35	10	15	12	4	15	0.045	0.06	
2SK1291	MP-25	60	±30	±120	60	10	15	12	4	15	0.045	0.06	
2SK1292	MP-45F	100	±20	±100	35	10	15	12	4	15	0.07	0.085	
2SK1293	MP-25	100	±30	±120	60	10	15	12	4	15	0.07	0.085	
2SK1294	MP-45F	60	±40	±160	35	10	20	12	4	20	0.03	0.05	
2SK1295	MP-45F	100	±30	±160	35	10	20	12	4	20	0.06	0.075	
2SK1491	MP-88	250	±25	±100	120	10	13	7.0	10	13	0.12	0.15	
2SK1492	MP-88	250	±35	±140	140	10	18	10	10	18	0.08	0.1	
2SK1493	MP-25	450	±3.0	±12	50	10	2.0	1.0	10	2.0	2.2	2.8	
2SK1494	MP-25	500	±3.0	±12	50	10	2.0	1.0	10	2.0	2.4	3.0	
2SK1495	MP-25	450	±7.0	±28	50	10	4.0	3.0	10	4.0	0.7	0.9	
2SK1496	MP-25	450	±7.0	±28	50	10	4.0	3.0	10	4.0	0.8	1.0	
2SK1497	MP-88	450	±20	±80	130	10	10	7.5	10	10	0.28	0.35	
2SK1498	MP-88	500	±20	±80	130	10	10	7.5	10	10	0.32	0.40	
2SK1499	MP-88	450	±25	±100	160	10	13	8.0	10	13	0.20	0.25	
2SK1500	MP-88	500	±25	±100	160	10	13	8.0	10	13	0.22	0.27	
2SK1501	MP-25	900	±4.0	±8.0	70	10	2.0	1.0	10	2.0	2.8	4.0	
2SK1502	MP-88	900	±7.0	±14	120	10	4.0	2.0	10	4.0	1.7	2.0	
2SK1594	MP-45F	30	±20	±80	30	10	10	7.0	4	10	0.05	0.08	
2SK1595	MP-45F	30	±30	±120	35	10	15	12	4	15	0.03	0.05	
2SK1596	MP-45F	30	±40	±160	35	10	20	20	4	20	0.02	0.03	
2SK1664	MP-45F	700	±2.0	±8.0	35	10	1.0	0.5	10	1.0	0.5	0.6	
2SK1748	MP-3	60	±8.0	±32	20	10	4.0	5.0	4	4.0	0.11	0.16	
2SK1749	MP-88	60	±50	±200	150	10	25	20	4	25	0.022	0.025	
2SK1750	MP-25	450	±5.0	±20	50	10	2.5	1.0	10	2.5	1.1	1.4	
2SK1751	MP-25	500	±5.0	±20	50	10	2.5	1.0	10	2.5	1.2	1.5	
2SK1752	MP-88	450	±10	±40	100	10	5.0	3.5	10	5.0	0.7	0.9	
2SK1753	MP-88	500	±10	±40	100	10	5.0	3.5	10	5.0	0.8	1.0	
2SK1756	MP-88	450	±15	±60	120	10	8.0	5.0	10	8.0	0.4	0.5	
2SK1757	MP-88	500	±15	±60	120	10	8.0	5.0	10	8.0	0.5	0.6	

Field Effect Transistor

■ 2SK type (4/5)

Type number	Package	Absolute maximum rating (T _A = 25 fC)				Electrical characteristics (T _A = 25 fC)							Applications
		V _{DSS} (V)	I _D		P _T T _C = 25 °C (W)	y _{fs} (S)			R _{DS(on)} (ȳ)				
			DC (A)	Pulse (A)		V _{DS} (V)	I _D (A)	MIN.	V _{GS} (V)	I _D (A)	TYP.	MAX.	
2SK1758	MP-45F	600	±2.0	±8.0	30	10	1.0	0.5	10	1.0	2.8	4.2	Switching
2SK1760	MP-88	900	±5.0	±10	100	20	3.0	1.0	10	3.0	3.1	4.0	
2SK1784	MP-88	450	±12	±48	100	10	6.0	1.5	10	6.0	0.5	0.6	
2SK1785	MP-88	500	±12	±48	100	10	6.0	1.5	10	6.0	0.6	0.7	
2SK1793	MP-25	900	±3.0	±6.0	75	20	2.0	0.8	10	2.0	6.2	7.5	
2SK1794	MP-88	900	±6.0	±12	100	20	3.0	2.0	10	3.0	1.8	2.8	
2SK1795	MP-88	900	±8.0	±16	140	20	4.0	1.0	10	4.0	1.3	1.6	
2SK1796	MP-88	900	±10	±20	150	20	5.0	1.5	10	5.0	1.0	1.2	
2SK1850	MP-10	60	±10	±40	1.8	10	5.0	7.0	4	5.0	0.08	0.095	
2SK1851	MP-10	60	±15	±60	1.8	10	7.5	12	4	7.5	0.045	0.06	
2SK1852	MP-10	100	±10	±40	1.8*	10	5.0	7.0	4	5.0	0.15	0.2	
2SK1853	MP-10	100	±15	±60	1.8*	10	7.5	12	4	7.5	0.08	0.1	
2SK1953	MP-45F	600	±2.0	±6.0	25*	20	1.0	0.5	10	1.0	4.2	5.0	
2SK1954	MP-3	180	±4.0	±16	20*	10	2.0	0.5	10	2.0	0.5	0.65	
2SK1987	MP-45F	250	±7.0	±28	30	10	4.0	2.1	10	4.0	0.4	0.5	
2SK1988	MP-45F	450	±2.5	±10	30	10	1.5	0.9	10	1.5	2.2	2.8	
2SK1989	MP-45F	500	±2.5	±10	30	10	1.5	0.9	10	1.5	2.4	3.0	
2SK1990	MP-45F	450	±4.5	±18	30	10	2.5	1.5	10	2.5	1.1	1.4	
2SK1991	MP-45F	500	±4.5	±18	30	10	2.5	1.5	10	2.5	1.2	1.5	
2SK1992	MP-45F	450	±6.0	±24	35	10	3.0	2.8	10	3.0	0.7	0.9	
2SK1993	MP-45F	500	±6.0	±24	35	10	3.0	2.8	10	3.0	0.8	1.0	
2SK1994	MP-45F	900	±2.0	±4.0	30	20	1.0	0.6	10	1.0	6.2	7.5	
2SK1995	MP-45F	900	±3.0	±6.0	35	20	2.0	1.0	10	2.0	3.2	4.0	
2SK2040	MP-3	600	±2.0	±6.0	20	20	1.0	0.5	10	1.0	4.2	5.0	
2SK2131	MP-45F	150	±15	±60	35	10	8.0	10	10	8.0	0.1	0.12	
2SK2132	MP-10	180	±4	±16	1.8	10	2.0	0.5	10	2.0	0.52	0.65	
2SK2133	MP-25	250	±16	±64	75	10	8.0	4.0	10	8.0	0.21	0.26	
2SK2134	MP-25	200	±13	±52	70*	10	7.0	2	10	7.0	0.32	0.4	
2SK2135	MP-45F	200	±14	±56	35	10	7.0	4	10	7.0	0.14	0.18	
2SK2136	MP-25	200	±20	±80	75	10	10	4	10	10	0.14	0.18	
2SK2137	MP-45F	600	±4	±16	30	10	20	1	10	2.0	2.0	2.4	
2SK2138	MP-25	600	±5	±20	70	10	2.5	1	10	2.5	2.0	2.4	
2SK2139	MP-45F	600	±5	±20	35	10	2.5	1.5	10	2.5	1.25	1.5	
2SK2140	MP-25	600	±7	±28	75	10	3.5	1.5	10	3.5	1.25	1.5	
2SK2141	MP-45F	600	±6	±24	40	10	3.0	2.0	10	3.0	0.9	1.1	
2SK2234	MP-45F	500	±8	±32	40	10	4.0	3.0	10	4.0	0.5	0.6	
2SK2275	MP-45F	900	±3.5	±7.0	35	20	2.0	4.0	10	2.0	2.4	2.8	
2SK2341	MP-45F	250	±11	±44	35	10	6.0	3.0	10	6.0	0.21	0.26	
2SK2409	MP-45F	60	±40	±160	35	10	20	20	4	20	0.03	0.05	
2SK2410	MP-45F	60	±30	±120	35	10	15	15	4	15	0.04	0.06	

*: T_A = 25°C

Field Effect Transistor

■ **2SK type (5/5)**

Type number	Package	Absolute maximum rating (T _A = 25 fC)				Electrical characteristics (T _A = 25 fC)							Applications
		V _{DSS} (V)	I _D		P _T T _C = 25 °C (W)	y _{fs} (S)			R _{DS(on)} (ȳ)				
			DC (A)	Pulse (A)		V _{DS} (V)	I _D (A)	MIN.	V _{GS} (V)	I _D (A)	TYP.	MAX.	
2SK2411	MP-25	60	±30	±120	75	10	15	15	4	15	0.04	0.06	Switching
2SK2412	MP-45F	60	±20	±80	30	10	10	7	4	10	0.067	0.095	
2SK2413	MP-10	60	±10	±40	1.8*	10	5	7	4	10	0.07	0.095	
2SK2414	MP-3	60	±10	±40	20	10	5	7	4	10	0.07	0.095	
2SK2415	MP-3	60	±8.0	±32	20	10	4	5	4	4	0.1	0.15	
2SK2461	MP-45F	100	±20	±80	35	10	10	12	4	10	0.07	0.1	
2SK2462	MP-45F	100	±15	±60	30	10	8	7	4	8	0.12	0.17	
2SK2476	MP-45F	800	±3.0	±9.0	40	20	2	1	10	2	3.4	5.0	
2SK2477	MP-45F	800	±10	±30	150	20	5	3.5	10	5	0.65	1.0	
2SK2478	MP-88	900	±2.0	±8.0	30	20	1	0.6	10	1	5.0	7.5	
2SK2479	MP-25	900	±3.0	±8.0	70	20	2	0.8	10	2	5.6	7.5	
2SK2480	MP-45F	900	±3.5	±12	35	20	2	1	10	2	3.2	4.0	
2SK2481	MP-25	900	±4.0	±12	70	20	2	1	10	2	3.2	4.0	
2SK2482	MP-88	900	±5.0	±12	100	20	3	1	10	3	3.2	4.0	
2SK2483	MP-45F	900	±3.5	±10.5	40	20	2	1	10	2	2.2	2.8	
2SK2484	MP-25	900	±5.0	±10	75	20	3	2	10	3	2.2	2.8	
2SK2485	MP-88	900	±6.0	±12	100	20	3	2	10	3	2.2	2.8	
2SK2486	MP-88	900	±7.0	±18	120	20	4	2.5	10	4	1.4	2.0	
2SK2487	MP-88	900	±8.0	±20	140	20	4	3.0	10	4	1.1	1.6	
2SK2488	MP-88	900	±10	±30	150	20	5	6	10	5	1.0	1.2	
2SK2498	MP-45F	60	±50	±200	35	10	25	20	4	25	0.011	0.014	
2SK2499	MP-25	60	±50	±200	75	10	25	20	4	25	0.011	0.014	
2SK2510	MP-45F	60	±40	±160	35	10	20	13	4	20	0.024	0.03	
2SK2511	MP-88	60	±40	±160	80	10	20	10	4	20	0.032	0.04	
2SK2512	MP-45F	60	±45	±180	35	10	23	15	4	23	0.016	0.023	
2SK2513	MP-25	60	±45	±180	75	10	23	15	4	23	0.016	0.023	
2SK2514	MP-88	60	±50	±200	150	10	25	15	4	25	0.016	0.023	
2SK2515	MP-88	60	±50	±200	150	10	25	20	4	25	0.011	0.014	

*: T_A = 25°C

■ **Power SOP8 series**

Type number	Package	Absolute maximum rating (T _A = 25 fC)				Electrical characteristics (T _A = 25 fC)							Applications
		V _{DSS} (V)	I _D		P _T T _C = 25 °C (W)	y _{fs} (S)			R _{DS(on)} (ȳ)				
			DC (A)	Pulse (A)		V _{DS} (V)	I _D (A)	MIN.	V _{GS} (V)	I _D (A)	TYP.	MAX.	
μPA1700*	PowerSOP8	30	±7	±28	2.0*	10	3.5	5.0	4	3.5	0.040	0.050	
μPA1701*	PowerSOP8	20	±7	±28	2.0*	10	3.5	5.0	2.5	3.5	0.031	0.048	

*: T_A = 25°C, Mounted on ceramic substrate of 1200 mm² ∞ 0.7 mm

*: Under development

Field Effect Transistor

■ 2SJ type

Type number	Package	Absolute maximum rating ($T_A = 25\text{ }^\circ\text{C}$)				Electrical characteristics ($T_A = 25\text{ }^\circ\text{C}$)							Applications
		V_{DSS} (V)	I_D		P_T $T_C = 25\text{ }^\circ\text{C}$ (W)	$ y_{fs} $ (S)			$R_{DS(on)}$ (Ω)				
			DC (A)	Pulse (A)		V_{DS} (V)	I_D (A)	MIN.	V_{GS} (V)	I_D (A)	TYP.	MAX.	
2SJ128	MP-3	-100	∓ 2	∓ 8	20	-10	-1	1	-4	-0.8	1.1	1.5	Switching
2SJ132	MP-3	-30	∓ 2	∓ 8	20	-10	-1	1	-4	-0.8	0.47	0.6	
2SJ133	MP-3	-60	∓ 2	∓ 8	20	-10	-1	1	-4	-0.8	0.7	1.3	
2SJ134	MP-25	-100	∓ 6	∓ 24	40	-10	-3.5	1	-4	-3.5	0.5	0.9	
2SJ135	MP-45	-100	∓ 5	∓ 20	30	-10	-3.5	1	-4	-3.5	0.5	0.9	
2SJ136	MP-25	-60	∓ 12	∓ 48	40	-10	-6.5	2	-4	-6.5	0.45	0.5	
2SJ137	MP-45	-60	∓ 10	∓ 40	30	-10	-6.5	2	-4	-6.5	0.45	0.5	
2SJ138	MP-25	-100	∓ 12	∓ 48	60	-10	-6.5	2	-4	-6.5	0.3	0.45	
2SJ139	MP-45	-100	∓ 10	∓ 40	35	-10	-6.5	2	-4	-6.5	0.3	0.45	
2SJ140	MP-25	-60	∓ 19	∓ 76	60	-10	-10	5	-4	-8	0.3	0.4	
2SJ141	MP-45	-60	∓ 13	∓ 52	35	-10	-10	5	-4	-8	0.3	0.4	
2SJ142	MP-45	-100	∓ 13	∓ 52	35	-10	-10	5	-4	-8	0.25	0.3	
2SJ143	MP-45	-60	∓ 16	∓ 64	35	-10	-10	5	-4	-10	0.22	0.25	
2SJ151	MP-25	-100	∓ 3.0	∓ 6.0	35	-10	-1.5	0.8	-4	-1.5	—	1.8	
2SJ152	MP-45	-100	∓ 3.0	∓ 6.0	30	-10	-1.5	0.8	-4	-1.5	—	1.8	
2SJ153	MP-25	-60	∓ 6.0	∓ 12	40	-10	-3.5	0.9	-4	-1.5	—	0.9	
2SJ154	MP-45	-60	∓ 5.0	∓ 10	30	-10	-3.5	0.9	-4	-1.5	—	0.9	
2SJ302	MP-25	-60	∓ 16	∓ 64	75	-10	-8	6.0	-4	-6	0.13	0.24	
2SJ303	MP-45F	-60	∓ 14	∓ 56	35	-10	-7	5.0	-4	-6	0.13	0.24	
2SJ324	MP-3	-30	∓ 2.0	∓ 8.0	20	-10	-1.0	1.0	-4	-0.8	0.40	0.52	
2SJ325	MP-3	-30	∓ 4.0	∓ 16	20	-10	-2.0	3.0	-4	-1.6	0.15	0.24	
2SJ326	MP-3	-60	∓ 2.0	∓ 8.0	20	-10	-1.0	1.0	-4	-0.8	0.5	0.68	
2SJ327	MP-3	-60	∓ 4.0	∓ 16	20	-10	-2.0	3.0	-4	-1.6	0.22	0.34	
2SJ328	MP-25	-60	∓ 20	∓ 80	75	-10	-10	8.0	-4	-8	0.085	0.11	
2SJ329	MP-45F	-60	∓ 15	∓ 60	35	-10	-8	8.0	-4	-6	0.085	0.11	
2SJ330	MP-45F	-60	∓ 20	∓ 80	35	-10	-10	10	-4	-8	0.065	0.09	
2SJ331	MP-88	-60	∓ 30	∓ 120	150	-10	-15	15	-4	-12	0.04	0.055	

Transistor with Internal Resistor

■ Equivalent circuit

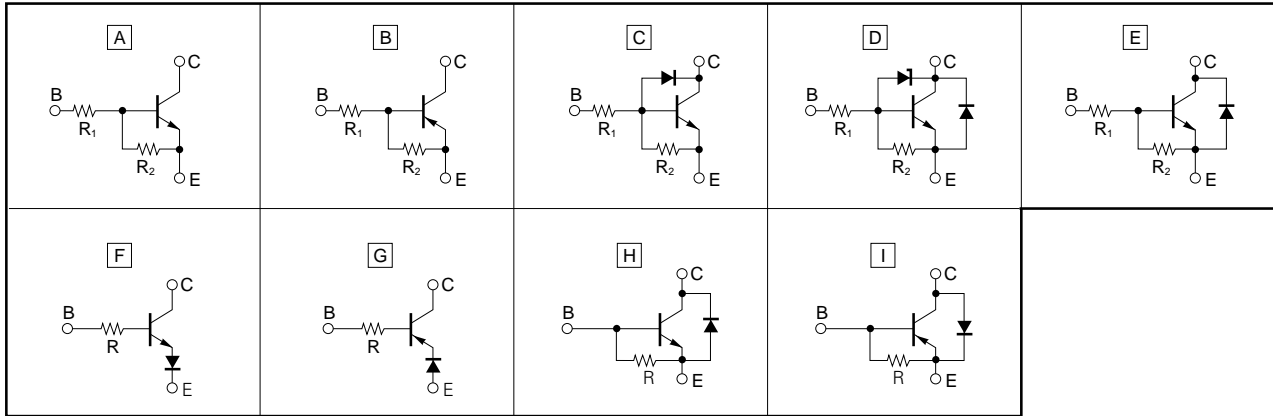

■ AA1[], AN1[], BA1[], BN1[] series (TO-92, SST)

Type number		Equivalent circuit and applications	Absolute maximum ratings ($T_A = 25\text{ }^\circ\text{C}$)						Electrical characteristics ($T_A = 25\text{ }^\circ\text{C}$)					
			V _{CB0} (V)	V _{CE0} (V)	V _{EB0} (V)	I _c (mA)	P _T (mW)	T _j ($^\circ\text{C}$)	R ₁ (k Ω)	R ₂ (k Ω)	h _{FE}	V _{CE} (V)	I _c (mA)	Remarks
TO-92	SST	Refer to equivalent circuit [A]	60	50	10	100	250	150	10	10	35 to 100	5.0	5.0	
AA1A4M	BA1A4M		60	50	5	100	250	150	10	47	35 to 340	5.0	5.0	
AA1A4P	BA1A4P		60	50	10	100	250	150	22	22	60 to 195	5.0	5.0	
AA1F4M	BA1F4M		60	50	5	100	250	150	22	47	85 to 340	5.0	5.0	
AA1F4N	BA1F4N		60	50	10	100	250	150	47	47	85 to 340	5.0	5.0	
AA1L4M	BA1L4M		60	50	15	100	250	150	47	22	60 to 195	5.0	5.0	
AA1L4L	BA1L4L		60	50	5	100	250	150	4.7	-	135 to 600	5.0	5.0	
AA1L3Z	BA1L3Z		60	50	5	100	250	150	10	-	135 to 600	5.0	5.0	
AA1A4Z	BA1A4Z		60	50	5	100	250	150	22	-	135 to 600	5.0	5.0	
AA1F4Z	BA1F4Z		60	50	5	100	250	150	47	-	135 to 600	5.0	5.0	
AA1L4Z	BA1L4Z		60	50	10	100	250	150	4.7	4.7	20 to 80	5.0	5.0	
AA1L3M	BA1L3M		60	50	5	100	250	150	4.7	10	35 to 100	5.0	5.0	
AA1A3Q	BA1A3Q		60	50	5	100	250	150	1.0	10	35 to 100	5.0	5.0	
AN1A4M	BN1A4M		Refer to equivalent circuit [B]	-60	-50	-10	-100	250	150	10	10	35 to 100	-5.0	-5.0
AN1A4P	BN1A4P	-60		-50	-5	-100	250	150	10	47	85 to 340	-5.0	-5.0	
AN1F4M	BNN1F4M	-60		-50	-10	-100	250	150	22	22	60 to 195	-5.0	-5.0	
AN1F4N	BN1F4N	-60		-50	-5	-100	250	150	22	47	85 to 340	-5.0	-5.0	
AN1L4M	BN1L4M	-60		-50	-10	-100	250	150	47	47	85 to 340	-5.0	-5.0	
AN1L4L	BN1L4L	-60		-50	-15	-100	250	150	47	22	60 to 195	-5.0	-5.0	
AN1L3Z	BN1L3Z	-60		-50	-5	-100	250	150	4.7	-	135 to 600	-5.0	-5.0	
AN1A4Z	BN1A4Z	-60		-50	-5	-100	250	150	10	-	135 to 600	-5.0	-5.0	
AN1F4Z	BN1F4Z	-60		-50	-5	-100	250	150	22	-	135 to 600	-5.0	-5.0	
AN1L4Z	BN1L4Z	-60		-50	-5	-100	250	150	47	-	135 to 600	-5.0	-5.0	
AN1L3M	BN1L3M	-60		-50	-10	-100	250	150	4.7	4.7	20 to 80	-5.0	-5.0	
AN1L3N	BN1L3N	-60		-50	-5	-100	250	150	4.7	10	35 to 100	-5.0	-5.0	
AN1A3Q	BNN1A3Q	-60		-50	-5	-100	250	150	1.0	10	35 to 100	-5.0	-5.0	

Transistor with Internal Resistor

■ **AB1[], AP1[], BB1[], BP1[] series (TO-92, SST)**

Type number		Equivalent circuit and applications	Absolute maximum ratings ($T_A = 25\text{ }^\circ\text{C}$)						Electrical characteristics ($T_A = 25\text{ }^\circ\text{C}$)					Re- marks	
			V _{CB0} (V)	V _{CE0} (V)	V _{EB0} (V)	I _C (A)	P _T (mW)		T _j ($^\circ\text{C}$)	R ₁ (k Ω)	R ₂ (k Ω)	h _{FE}	V _{CE} (V)		I _C (A)
TO-92	SST					TO-92	SST								
AB1A4A	BB1A4A	Refer to equivalent circuit [A]	30	25	10	0.7	750	250	150	-	10	300 ~	2.0	0.5	
AB1L2Q	BB1L2Q		30	25	10	0.7	750	250	150	0.47	4.7	300 ~	2.0	0.5	
AB1A3M	BB1A3M		30	25	10	0.7	750	250	150	1.0	1.0	100 ~	2.0	0.5	
AB1F3P	BB1F3P		30	25	10	0.7	750	250	150	2.2	10	300 ~	2.0	0.5	
AB1J3P	BB1J3P		30	25	10	0.7	750	250	150	3.3	10	300 ~	2.0	0.5	
AB1L3N	BB1L3N		30	25	10	0.7	750	250	150	4.7	10	300 ~	2.0	0.5	
AB1A4M	BB1A4M	Switching	30	25	10	0.7	750	250	150	10	10	300 ~	2.0	0.5	
AP1A4A	BP1A4A	Refer to equivalent circuit [B]	-25	-25	-10	-0.7	750	250	150		10	100 ~	-2.0	-0.5	
AP1L2Q	BP1L2Q		-25	-25	-10	-0.7	750	250	150	0.47	4.7	100 ~	-2.0	-0.5	
AP1A3M	BP1A3M		-25	-25	-10	-0.7	750	250	150	1.0	1.0	100 ~	-2.0	-0.5	
AP1F3P	BP1F3P		-25	-25	-10	-0.7	750	250	150	2.2	10	100 ~	-2.0	-0.5	
AP1J3P	BP1J3P		-25	-25	-10	-0.7	750	250	150	3.3	10	100 ~	-2.0	-0.5	
AP1L3N	BP1L3N		-25	-25	-10	-0.7	750	250	150	4.7	10	100 ~	-2.0	-0.5	
AP1A4M	BP1A4M	Switching	-25	-25	-10	-0.7	750	250	150	10	10	100 ~	-2.0	-0.5	

■ **AC1[], AQ1[] series (TO-92)**

Type number		Equivalent circuit and applications	Absolute maximum ratings ($T_A = 25\text{ }^\circ\text{C}$)						Electrical characteristics ($T_A = 25\text{ }^\circ\text{C}$)					Remarks
			V _{CB0} (V)	V _{CE0} (V)	V _{EB0} (V)	I _C (A)	P _T (mW)	T _j ($^\circ\text{C}$)	R ₁ (k Ω)	R ₂ (k Ω)	h _{FE}	V _{CE} (V)	I _C (A)	
TO-92														
AC1A4A		Refer to equivalent circuit [A]	20	20	10	2.0	750	150	-	10	300 ~	2.0	1.0	
AC1F2Q			20	20	10	2.0	750	150	0.22	2.2	300 ~	2.0	1.0	
AC1L2N			20	20	10	2.0	750	150	0.47	1.0	300 ~	2.0	1.0	
AC1L2Q			20	20	10	2.0	750	150	0.47	4.7	300 ~	2.0	1.0	
AC1A3M			20	20	10	2.0	750	150	1.0	1.0	300 ~	2.0	1.0	
AC1F3M			20	20	10	2.0	750	150	2.2	2.2	300 ~	2.0	1.0	
AC1F3P		Switching	20	20	10	2.0	750	150	4.7	10	300 ~	2.0	1.0	
AQ1A4A		Refer to equivalent circuit [B]	-20	-20	-10	-2.0	750	150	-	10	150 ~	-2.0	-1.0	
AQ1F2Q			-20	-20	-10	-2.0	750	150	0.22	2.2	150 ~	-2.0	-1.0	
AQ1L2N			-20	-20	-10	-2.0	750	150	0.47	1.0	150 ~	-2.0	-1.0	
AQ1L2Q			-20	-20	-20	-10	750	150	0.47	4.7	150 ~	-2.0	-1.0	
AQ1A3M			-20	-20	-10	-2.0	750	150	1.0	1.0	150 ~	-2.0	-1.0	
AQ1F3M			-20	-20	-10	-2.0	750	150	2.2	2.2	150 ~	-2.0	-1.0	
AQ1F3P		Switching	-20	-20	-10	-2.0	750	150	4.7	10	150 ~	-2.0	-1.0	

Transistor with Internal Resistor

■ AC2[], AQ2[] series (TO-92)

Type number	Equivalent circuit and applications	Absolute maximum ratings (TA = 25 fC)						Electrical characteristics (TA = 25 fC)					Remarks
		VcBo (V)	VcEO (V)	VEBO (V)	Ic (A)	P _T (mW)	T _J (fC)	R ₁ (kΩ)	R ₂ (kΩ)	hFE	VCE (V)	Ic (A)	
TO-92													
AC2A4A	Refer to [H]	20	16	6.0	±3.0	750	150	–	10	135 ~	2.0	0.1	
AQ2A4A	Refer to [I]	–20	–16	–6.0	±3.0	750	150	–	10	135 ~	–2.0	–0.1	

■ AD1[], AD2[], AR1[] series (TO-92)

Type number	Equivalent circuit and applications	Absolute maximum ratings (TA = 25 fC)						Electrical characteristics (TA = 25 fC)					Remarks
		VcBo (V)	VcEO (V)	VEBO (V)	Ic (A)	P _T (mW)	T _J (fC)	R ₁ (kΩ)	R ₂ (kΩ)	hFE	VCE (V)	Ic (A)	
TO-92													
AD1A3M	Refer to equivalent circuit [A] Switching	80	60	10	1.0	750	150	1.0	1.0	200 ~	2.0	0.5	
AD1F3P		80	60	10	1.0	750	150	2.2	10	300 ~	2.0	0.5	
AD1L3N		80	60	10	1.0	750	150	4.7	10	300 ~	2.0	0.5	
AD1A4M		80	60	10	1.0	750	150	10	10	300 ~	2.0	0.5	
AD1L2Q		80	60	10	1.0	750	150	0.47	4.7	300 ~	2.0	0.5	
AD1F2Q		80	60	10	1.0	750	150	0.22	2.2	300 ~	2.0	0.5	
AD1A4A		80	60	10	1.0	750	150	–	10	300 ~	2.0	0.5	
AD2A3M		Refer to equivalent circuit [C] Switching	60 ±10	60 ±10	10	1.0	750	150	1.0	1.0	200 ~	2.0	0.5
AD2F3P	60 ±10		60 ±10	10	1.0	750	150	2.2	10	300 ~	2.0	0.5	
AD2L3N	60 ±10		60 ±10	10	1.0	750	150	4.7	10	300 ~	2.0	0.5	
AD2A4M	60 ±10		60 ±10	10	1.0	750	150	10	10	300 ~	2.0	0.5	
AD2L2Q	60 ±10		60 ±10	10	1.0	750	150	0.47	4.7	300 ~	2.0	0.5	
AD2F2Q	60 ±10		60 ±10	10	1.0	750	150	0.22	2.2	300 ~	2.0	0.5	
AD2A4A	60 ±10		60 ±10	10	1.0	750	150	–	10	300 ~	2.0	0.5	
AR1A3M	Refer to equivalent circuit [B] Switching		–60	–60	–10	–1.0	750	150	1.0	1.0	100 ~	–2.0	–0.5
AR1F3P		–60	–60	–10	–1.0	750	150	2.2	10	100 ~	–2.0	–0.5	
AR1L3N		–60	–60	–10	–1.0	750	150	4.7	10	100 ~	–2.0	–0.5	
AR1A4M		–60	–60	–10	–1.0	750	150	10	10	100 ~	–2.0	–0.5	
AR1L2Q		–60	–60	–10	–1.0	750	150	0.47	4.7	100 ~	–2.0	–0.5	
AR1F2Q		–60	–60	–10	–1.0	750	150	0.22	2.2	100 ~	–2.0	–0.5	
AR1A4A		–60	–60	–10	–1.0	750	150	–	10	100 ~	–2.0	–0.5	

■ CE1[], CE2[] series (SP-8)

Type number	Equivalent circuit and applications	Absolute maximum ratings (TA = 25 fC)						Electrical characteristics (TA = 25 fC)					
		VcBo (V)	VcEO (V)	VEBO (V)	Ic (A)	P _T (W)	T _J (fC)	R ₁ (kΩ)	R ₂ (kΩ)	hFE	VCE (V)	Ic (A)	
SP-8													
CE1A3Q	Refer to [D]	60 ±10	60 ±10	15	±2.0	1.0	150	1.0	10	1000 to 3000	5.0	1.0	
CE1F3P		60 ±10	60 ±10	15	±2.0	1.0	150	2.2	10	1000 to 3000	5.0	1.0	
CE1N2R		60 ±10	60 ±10	15	±2.0	1.0	150	0.68	10	1000 to 3000	5.0	1.0	
CE2A3Q	Refer to [E]	60	60	15	±2.0	1.0	150	1.0	10	1000 to 3000	5.0	1.0	
CE2F3P		60	60	15	±2.0	1.0	150	1.0	10	1000 to 3000	5.0	1.0	

Transistor with Internal Resistor

■ **BA2[], BN2[] series (SST)**

Type number	Equivalent circuit and applications	Absolute maximum ratings ($T_A = 25\text{ }^\circ\text{C}$)						Electrical characteristics ($T_A = 25\text{ }^\circ\text{C}$)					Remarks
		V _{CB0} (V)	V _{CE0} (V)	V _{EB0} (V)	I _C (mA)	P _T (mW)	T _j ($^\circ\text{C}$)	R ₁ (k Ω)	R ₂ (k Ω)	h _{FE}	V _{CE} (V)	I _C (mA)	
SST													
BA2A4M	Refer to equivalent circuit A	60	50	20	100	250	150	10	10	60 to 105	5.0	5.0	
BA2A4P		60	50	10	100	250	150	10	47	230 to 460	5.0	5.0	
BA2F4M		60	50	20	100	250	150	22	22	125 to 230	5.0	5.0	
BA2F4N		60	50	15	100	250	150	22	47	230 to 460	5.0	5.0	
BA2L4M		60	50	20	100	250	150	47	47	230 to 460	5.0	5.0	
BA2L4L		60	50	30	100	250	150	47	22	125 to 230	5.0	5.0	
BA2L3Z		60	50	10	100	250	150	4.7	-	1000 to 3200	5.0	5.0	
BA2A4Z		60	50	10	100	250	150	10	-	1000 to 3200	5.0	5.0	
BA2F4Z		60	50	10	100	250	150	22	-	1000 to 3200	5.0	5.0	
BA2L4Z		60	50	10	100	250	150	47	-	1000 to 3200	5.0	5.0	
BA2L3M		60	50	20	100	250	150	4.7	4.7	30 to 50	5.0	5.0	
BA2L3N		60	50	15	100	250	150	4.7	10	60 to 105	5.0	5.0	
BA2A3Q		60	50	10	100	250	150	1.0	10	60 to 105	5.0	5.0	
BN2A4M		Refer to equivalent circuit B	-25	-25	-20	-100	250	150	10	10	55 to 90	-5.0	-5.0
BN2A4P	-25		-25	-10	-100	250	150	10	47	200 to 350	-5.0	-5.0	
BN2F4M	-25		-25	-20	-100	250	150	22	22	115 to 200	-5.0	-5.0	
BN2F4N	-25		-25	-15	-100	250	150	22	47	200 to 350	-5.0	-5.0	
BN2L4M	-25		-25	-30	-100	250	150	47	47	200 to 350	-5.0	-5.0	
BN2L4L	-25		-25	-20	-100	250	150	47	22	115 to 200	-5.0	-5.0	
BN2L3Z	-25		-25	-10	-100	250	150	4.7	-	800 to 1200	-5.0	-5.0	
BN2A4Z	-25		-25	-10	-100	250	150	10	-	800 to 1200	-5.0	-5.0	
BN2F4Z	-25		-25	-10	-100	250	150	22	-	800 to 1200	-5.0	-5.0	
BN2L4Z	-25		-25	-10	-100	250	150	47	-	800 to 1200	-5.0	-5.0	
BN2L3M	-25		-25	-20	-100	250	150	4.7	4.7	30 to 45	-5.0	-5.0	
BN2L3N	-25		-25	-15	-100	250	150	4.7	10	55 to 90	-5.0	-5.0	
BN2A3Q	-25		-25	-10	-100	250	150	1.0	10	65 to 90	-5.0	-5.0	

■ **BA3[], BN3[] series (SST)**

Type number	Equivalent circuit and applications	Absolute maximum ratings ($T_A = 25\text{ }^\circ\text{C}$)					Electrical characteristics ($T_A = 25\text{ }^\circ\text{C}$)				
		V _{CB0} (V)	V _{CE0} (V)	V _{EB0} (V)	V _R (V)	P _T (mW)	T _j (k Ω)	R (k Ω)	h _{FE}	V _{CE} (V)	I _C (mA)
BA3L4Z	Refer to F	20	20	5	6	250	150	47	30 ~	2.0	1.0
BN3L4Z	Refer to G	-20	-20	-5	6	250	150	47	30 ~	-2.0	-1.0

Transistor for Array

Equivalent Circuit

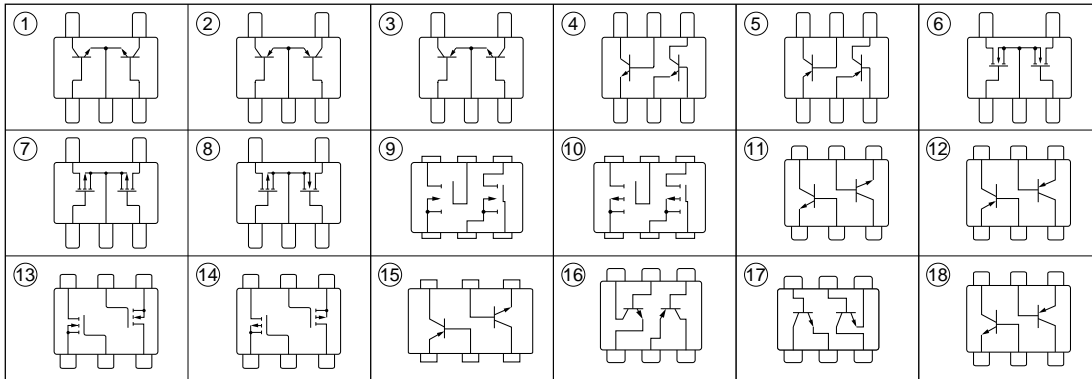

■ Bipolar Transistor

Type number	Equivalent circuit	V _{CEO} (V)	I _{C(DC)} (mA)	P _{T*} (mW)	h _{FE}	h _{FE}		Package	
						V _{CE} (V)	I _C (mA)		
μPA570T	●	50	100	200	90 to 600	6	1	• 5-pin Super Mini-Mold	
μPA571T	●	-50	-100	200		-6	-1		
μPA574T	●	50/-50	100/-100	300		6/-6	1/-1		
μPA670T	●	50	100	200		6	1		• 6-pin Super Mini-Mold
μPA671T	●	-50	-100	200		-6	-1	• 5-pin Mini-Mold	
μPA500T	●	50	100	300		6	1		
μPA501T	●	-50	-100	300		-6	-1		
μPA504T	●	50/-50	100/-100	300		6/-6	1/-1		
μPA600T	●	50	100	300		6	1	• 6-pin Mini-Mold	
μPA601T	●	-50	-100	300		-6	-1		
μPA604T	●	50	100	300		6	1		
μPA605T	●	-50	-100	300		-6	-1		
μPA608T	●	50 -16	100 -500	300		90 to 600 110 to 400	6 -1	1 -100	• 6-pin Super Mini-Mold
μPA609T	●	40 -40	500 -500	300		75 to 300 75 to 300	1 -1	150 -150	
μPA673T	●	15	200	200	82 to 180	6	1		
μPA674T	●	15 -15	200 -50	200	40 to 200 50 to 150	1 -1	10 -10	• 6-pin Super Mini-Mold	

*: Total

■ MOS FET

Type number	Equivalent circuit	V _{DSS} (V)	I _{D(DC)} (mA)	P _{T*} (mW)	R _{DS(on)} (Ω) MAX	R _{DS(on)}		Package
						V _{GS} (V)	I _D (mA)	
μPA572T	●	30	100	200	13	2.5	10	• 5-pin Super Mini-Mold
μPA573T	●	-30	-100	200	60	-2.5	-10	
μPA502T	●	50	100	300	30	4	10	
μPA503T	●	-50	-100	300	100	-4	-10	• 5-pin Mini-Mold
μPA505T	●	50/-50	100/-100	300	30/100	4/-4	10/-10	
μPA602T	●	50	100	300	30	4	10	• 6-pin Mini-Mold
μPA603T	●	-50	-100	300	100	-4	-10	
μPA606T	●	50	100	300	30	4	10	
μPA607T	●	-50	-100	300	100	-4	-10	
μPA672T	●	50	100	200	40	2.5	10	• 6-pin Super Mini-Mold

*: Total

Power MOS IC

Type number	Function	Withstand Voltage (V)	Output Current (A)	Package	Main Application
μ PD16804	Control the revolution direction of the DC motor (1 unit)	6.5/8.0*	0.5	• 16-pin SOP	Camera motor drive
μ PD16805			1.0		
μ PD16823	Control the revolution direction of the DC motor (1.5 unit)		0.5	• 20-pin SOP	
μ PD16812A*	<ul style="list-style-type: none"> High side switch Protection for over current and over heating 	60 ($\tau \leq 250$ ms)	2.0	• 5-pin MP-45F	Automotive solenoid driver

*: Charge Pump Circuit used / Charge Pump Circuit not used

*: Under development

Transistor Array

■ Signal transistor array

Type Number	Number of circuits				Output voltage VO (V)	Output current IO (mA/Unit)	Surge absorber diode	Input impedance	Active level		Input/output relationship		Output current relationship		Remarks	Number of pins
	5	6	7	8					"H"	"L"	Inverter type	Non-inverter type	Source type	Sink type		
μ PA53C	○				30	400	-	20 k Ω	○		○			○	Darlington	14
μ PA56C			○		40	100	-	-	○			○	○		Single (Common collector)	16
μ PA57C		○			30	400	-	4 k Ω	○		○			○	Darlington	14 with tab
μ PA67C		○			30	70	-	22 k Ω	○		○			○	Darlington	14
μ PA79C			○		20	150*1	○	20 K Ω	○		○			○	Low saturation driver	16
μ PA80C, GR			○		60	50	-	20 k Ω		○	○			○	Darlington	16
μ PA81C			○		45	400*2	-	20 k Ω	○		○			○	FIP driver	18
μ PA2001C, GR			○		60	500	○	-	○		○			○	Darlington	16
μ PA2002C, GR			○		60	500	○	7VZDi +10.5 k Ω	○		○			○	Darlington	16
μ PA2003C, GR			○		60	500	○	2.7 k Ω	○		○			○	Darlington	16
μ PA2004C, GR			○		60	500	○	10.5 k Ω	○		○			○	Darlington	16
μ PA2981C			○		50	500	○	3 k Ω	○			○	○		Darlington output stage	18
μ PA2982C			○		50	500	○	8.5 k Ω	○			○	○		Darlington output stage	18
μ PA2987C			○		50	500	○	3 k Ω	○			○	○		Darlington output stage	16
μ PA6118C			○		85	40	-	37 k Ω	○			○	○		FIP driver	18

*1: PW \leq 30 ms, duty cycle \leq 10% (7 circuits operation)

*2: PW \leq 10 ms, duty cycle \leq 10% (7 circuits operation)

Transistor Array

■ **Power transistor array**

Type Number	Number of circuits	Collector-emitter voltage VCE (V)	Collector current IC (A)	Surge absorber diode	Input impedance	Output current relationship		Remarks	Number of pins
						Source type	Sink type		
μPA1424H	4	60 ±10	±2.0	○	680 Ω		○	High beta	10
μPA1426H	4	80	±2.0	—	—		○	Darlington	10
μPA1427H	4	−80	∓2.0	—	—	○		Darlington	10
μPA1428H	4	60 ±10	±2.0	○	—		○	Darlington	10
μPA1428AH									
μPA1434H	4	60	3.0	—	—		○	High beta	10
μPA1436H	4	100	±3.0	—	—		○	Darlington	10
μPA1436AH									
μPA1437H	4	−100	∓3.0	—	—	○		Darlington	10
μPA1438H	4	60 ±10	±3.0	○	—		○	Darlington	10
μPA1452H	4	60	5.0	—	—		○	Low VCE(sat)	10
μPA1453H	4	−60	5.0	—	—	○		Low VCE(sat)	10
μPA1454H	4	100	5.0	—	—		○	High beta	10
μPA1456H	4	100	±5.0	—	—		○	Darlington	10
μPA1457H	4	−100	∓5.0	—	—	○		Darlington	10
μPA1458H	4	60 ±10	±5.0	○	—		○	Darlington	10
μPA1476H	4	100 ±15	±2.0	○	—		○	Darlington	10
μPA1478H	4	31 ±4	±2.0	○	—		○	Darlington	10

■ **Power MOS FET array**

Type Number	Number of circuits			V _{DSS} (V)	I _D (A/Unit)	Surge absorber diode	4 V driving	Active level		Input/output relationship		Output current relationship		Number of pins
	4	7	8					"H"	"L"	Inverter type	Non-inverter type	Source type	Sink type	
μPA1500H/1500BH	○			60	±3	○	○	○		○			○	12
μPA1501H	○			120	±3	○	○	○		○			○	12
μPA1520H/1520BH	○			30	±2	—	○	○		○			○	10
μPA1522H	○			60	±2	—	○	○		○			○	10
μPA1523H/1523BH*	○			−60	∓2	—	○		○		○		○	10
μPA1524H	○			80	±2	—	○	○		○			○	10
μPA1526H	○			100	±2	—	○	○		○			○	10
μPA1527H	○			−100	∓2	—	○		○		○		○	10
μPA1550H	○			30	±5	—	○	○		○			○	10
μPA1552H/1552AH	○			60	±5	—	○	○		○			○	10
μPA1552BH														
μPA1556H/1556AH	○			100	±5	—	○	○		○			○	10
μPA1570H	○			30	±2	—	○	○		○			○	10
μPA1572H	○			60	±2	—	○	○		○			○	10
μPA1576H	○			100	±2	—	○	○		○			○	10

★: Under development

■ **Monolithic MOS FET array**

Type Number	Number of circuits			V _{DSS} (V)	I _D (A/Unit)	Surge absorber diode	4 V driving	Active level		Input/output relationship		Output current relationship		Number of pins
	4	7	8					"H"	"L"	Inverter type	Non-inverter type	Source type	Sink type	
μPA1600CX/GS			○	30	0.5	—	○	○		○			○	20
μPA1601CX/GS		○		30	0.43	—	○	○		○			○	16
μPA1602CX/GS		○		30	0.43	—	○		○		○		○	16
μPA1603CX	○			30	0.87	○	○	○		○			○	16
μPA1604CX	○			30	0.87	○	○		○		○		○	16
μPA1640GS			○	30	0.1	—	○	○		○			○	20

Zener Diode

■ Zener Diode Quick Reference (1/2)

Vz (V)	P (W)						
	0.15		0.2			1.0	
TYP.							
2.0		RD2.0UM	RD2.0M		RD2.0S	RD2.0P	
2.2		RD2.2UM	RD2.2M		RD2.2S	RD2.2P	
2.4		RD2.4UM	RD2.4M	RD2.4MW	RD2.4S	RD2.4P	
2.7		RD2.7UM	RD2.7M	RD2.7MW	RD2.7S	RD2.7P	
3.0		RD3.0UM	RD3.0M	RD3.0MW	RD3.0S	RD3.0P	
3.3		RD3.3UM	RD3.3M	RD3.3MW	RD3.3S	RD3.3P	
3.6		RD3.6UM	RD3.6M	RD3.6MW	RD3.6S	RD3.6P	
3.9		RD3.9UM	RD3.9M	RD3.9MW	RD3.9S	RD3.9P	
4.3		RD4.3UM	RD4.3M	RD4.3MW	RD4.3S	RD4.3P	
4.7	RD4.7UJ	RD4.7UM	RD4.7M	RD4.7MW	RD4.7S	RD4.7P	RD4.7FM
5.1	RD5.1UJ	RD5.1UM	RD5.1M	RD5.1MW	RD5.1S	RD5.1P	RD5.1FM
5.6	RD5.6UJ	RD5.6UM	RD5.6M	RD5.6MW	RD5.6S	RD5.6P	RD5.6FM
6.2	RD6.2UJ	RD6.2UM	RD6.2M	RD6.2MW	RD6.2S	RD6.2P	RD6.2FM
6.8	RD6.8UJ	RD6.8UM	RD6.8M	RD6.8MW	RD6.8S	RD6.8P	RD6.8FM
7.5	RD7.5UJ	RD7.5UM	RD7.5M	RD7.5MW	RD7.5S	RD7.5P	RD7.5FM
8.2	RD8.2UJ	RD8.2UM	RD8.2M	RD8.2MW	RD8.2S	RD8.2P	RD8.2FM
9.1	RD9.1UJ	RD9.1UM	RD9.1M	RD9.1MW	RD9.1S	RD9.1P	RD9.1FM
10	RD10UJ	RD10UM	RD10M		RD10S	RD10P	RD10FM
11	RD11UJ	RD11UM	RD11M		RD11S	RD11P	RD11FM
12	RD12UJ	RD12UM	RD12M		RD12S	RD12P	RD12FM
13	RD13UJ	RD13UM	RD13M		RD13S	RD13P	RD13FM
15	RD15UJ	RD15UM	RD15M		RD15S	RD15P	RD15FM
16	RD16UJ	RD16UM	RD16M		RD16S	RD16P	RD16FM
18	RD18UJ	RD18UM	RD18M		RD18S	RD18P	RD18FM
20	RD20UJ	RD20UM	RD20M		RD20S	RD20P	RD20FM
22	RD22UJ	RD22UM	RD22M		RD22S	RD22P	RD22FM
24	RD24UJ	RD24UM	RD24M		RD24S	RD24P	RD24FM
27	RD27UJ	RD27UM	RD27M		RD27S	RD27P	RD27FM
30	RD30UJ	RD30UM	RD30M		RD30S	RD30P	RD30FM
33	RD33UJ	RD33UM	RD33M		RD33S	RD33P	RD33FM
36	RD36UJ	RD36UM	RD36M		RD36S	RD36P	RD36FM
39	RD39UJ	RD39UM	RD39M		RD39S	RD39P	RD39FM
43			RD43M			RD43P	RD43FM
47			RD47M			RD47P	RD47FM
51						RD51P	RD51FM
56						RD56P	
62						RD62P	
68						RD68P	
75						RD75P	
82						RD82P	
91						RD91P	
100						RD100P	
110						RD110P	
120						RD120P	
Package	2-pin ultra mini-mold		Mini-mold (SC-59)	2-pin mini-mold	Power mini-mold (SC-62)	2-pin power mini-mold	
	Low noise	General Purpose					

Zener Diode

■ Zener Diode Quick Reference (2/2)

Vz (V)	P (W)				
	0.25	0.4	0.4	0.5	1.0
TYP.					
2.0	RD2.0HS		RD2.0ES	RD2.0E	RD2.0F
2.2	RD2.2HS		RD2.2ES	RD2.2E	RD2.2F
2.4	RD2.4HS		RD2.4ES	RD2.4E	RD2.4F
2.7	RD2.7HS		RD2.7ES	RD2.7E	RD2.7F
3.0	RD3.0HS		RD3.0ES	RD3.0E	RD3.0F
3.3	RD3.3HS		RD3.3ES	RD3.3E	RD3.3F
3.6	RD3.6HS		RD3.6ES	RD3.6E	RD3.6F
3.9	RD3.9HS		RD3.9ES	RD3.9E	RD3.9F
4.3	RD4.3HS		RD4.3ES	RD4.3E	RD4.3F
4.7	RD4.7HS	RD4.7JS	RD4.7ES	RD4.7E	RD4.7F
5.1		RD5.1JS	RD5.1ES	RD5.1E	RD5.1F
5.6		RD5.6JS	RD5.6ES	RD5.6E	RD5.6F
6.2		RD6.2JS	RD6.2ES	RD6.2E	RD6.2F
6.8		RD6.8JS	RD6.8ES	RD6.8E	RD6.8F
7.5		RD7.5JS	RD7.5ES	RD7.5E	RD7.5F
8.2		RD8.2JS	RD8.2ES	RD8.2E	RD8.2F
9.1		RD9.1JS	RD9.1ES	RD9.1E	RD9.1F
10		RD10JS	RD10ES	RD10E	RD10F
11		RD11JS	RD11ES	RD11E	RD11F
12		RD12JS	RD12ES	RD12E	RD12F
13		RD13JS	RD13ES	RD13E	RD13F
15		RD15JS	RD15ES	RD15E	RD15F
16		RD16JS	RD16ES	RD16E	RD16F
18		RD18JS	RD18ES	RD18E	RD18F
20		RD20JS	RD20ES	RD20E	RD20F
22		RD22JS	RD22ES	RD22E	RD22F
24		RD24JS	RD24ES	RD24E	RD24F
27		RD27JS	RD27ES	RD27E	RD27F
30		RD30JS	RD30ES	RD30E	RD30F
33		RD33JS	RD33ES	RD33E	RD33F
36		RD36JS	RD36ES	RD36E	RD36F
39		RD39JS	RD39ES	RD39E	RD39F
43				RD43E	RD43F
47				RD47E	RD47F
51				RD51E	RD51F
56				RD56E	RD56F
62				RD62E	RD62F
68				RD68E	RD68F
75				RD75E	RD75F
82				RD82E	RD82F
91				RD91E	
100				RD100E	
110				RD110E	
120				RD120E	
Package	DO-34	DO-34	DO-34	DO-35	DO-41

Thyristor

■ **SCR**

Package																	
	SOT-89		TO-92		MP-3			TO-202AA					MP-25		MP-45C		
Electrical characteristics	SOT-89		TO-92		MP-3			TO-202AA					MP-25		MP-45C		
$I_{T(RMS)}$ (A)	0.47	0.47	4.7	8	12.6	4	4	4	4.7	4.7	8	12	8	12			
$I_{T(AV)}$ (A)	0.3	0.3	3	5	8	2	2	2.5	3	3	5	8	5	8			
I_{TSM} (A)	6	8	35	65	80	20	20	35	65	-	80	100	80	100			
T_j (°C)	125		125		125			125					125		125		
V_{DRM} V_{RRM} (V)	200	03P2J	03P2M	-	-	-	-	-	-	2S2M	-	-	-	-	8P2M	-	8P2SM
	400	03P4J	03P4M	-	03P4MG	3P4J	5P4J	8P4J	2P4M	2S4M	2V5P4M	3P4MH	3S4M	5P4M	8P4M	5P4SM	8P4SM
	500	03P5J	-	03P4MF	03P5MG	-	-	-	2P5M	-	-	3P5MH	-	5P5M	-	-	-
	600	-	-	-	03P6MG	-	5P6J	5P6J-Z	-	2P6M	-	-	3P6MH	-	5P6M	-	5P6SM
I_{GT} (mA)	0.2	0.2	50 μ A	3-50 μ A	0.1	0.2	10*	0.2	0.3	0.1	0.2	30	10	10	10	10	
t_q (TYP.) (μ s)	25	25	100	60	80	100	50	30	15*	80	80	5*	50	100	50	100	

*: indicates MAX.

■ **TRIAC**

Package																		
	SOT-89		TO-92		MP-3		TO-202AA	MP-25					MP-45C					
Electrical characteristics	SOT-89		TO-92		MP-3		TO-202AA	MP-25					MP-45C					
$I_{T(RMS)}$ (A)	1.0	0.8	1.0	3	5	3	5	8	10	12	16	3	5	8	10	12	16	
$I_{TSM(50 Hz)}$ (A)	7.0	7	10	30	50	30	50	80	80	100	150	30	50	80	80	100	150	
T_j (°C)	125		125		125		125	125					125					
V_{DRM} V_{RRM} (V)	400	AC01DJM	AC0V	AC01	AC03	AC05	AC03	AC05	AC08	AC10	AC12	AC16	AC03	AC05	AC08	AC10	AC12	AC16
			8DGM	DGM	DJM	DJM	DGM	DGM	DGM	DGM	DGM	DGM	DSM	DSM	DSM	DSM	DSM	DSM
					AC03	AC05	AC03	AC05	AC08	AC10	AC12	AC16	-	AC05	AC08	AC10	AC12	-
				AC03	AC05	AC03	AC05	AC08	AC10	AC12	AC16	AC03	AC05	AC08	AC10	AC12	AC16	
				AC03	AC05	AC03	AC05	AC08	AC10	AC12	AC16	AC03	AC05	AC08	AC10	AC12	AC16	
				FJM	FJM	FGM	FGM	FGM	FGM	FGM	FGM	FSM	FSM	FSM	FSM	FSM	FSM	
				AC03	AC05	AC03	AC05	AC08	AC10	AC12	AC16	AC03	AC05	AC08	AC10	AC12	AC16	
				FJM-Z	FJM-Z	FGM	FGM	FGM	FGM	FGM	FGM	FSM	FSM	FSM	FSM	FSM	FSM	
I_{GT} (mA)	I	5	5	3	12	10	12	10	20	20	20	30	12	10	20	20	20	30
	II	10	10	5	-	-	-	-	-	-	-	-	-	-	-	-	-	-
	III	5	5	3	12	10	12	10	20	20	20	30	12	10	20	20	20	30
	IV	10	10	3	12	10	12	10	20	20	20	30	12	10	20	20	20	30
$(dv/dt)_c$ (V/ μ s)	MIN.	0.5	1	0.5	5	5	5	5	10	10	10	10	5	5	10	10	10	10

EMPTY PAGE

Microwave Device/Consumer-Use High Frequency Device

Microwave Device	166
• GaAs MMIC	166
• GaAs MCIC	166
• Field Effect Transistor	167
• Transistor	168
• Diode	169
Consumer-Use High Frequency Device	170
• MMIC	170
• Transistor, FET	176
• Diode	177



GaAs MMIC

■ Analog IC

Type number	Function	Features	Package
μ PG100	Wide band, low noise amplifier	f = 50 MHz to 3 GHz Gp \geq 14 dB, Nf \leq 3.5 dB	• 8-pin ceramic, Chip
μ PG101	Wide band, medium output amplifier	f = 50 MHz to 3 GHz Po (1dB) \geq 16 dBm	• 8-pin ceramic, Chip
μ PG103	Wide band, low noise amplifier	f = 50 MHz to 3 GHz Gp \geq 10 dB, Nf \leq 5 dB	• 8-pin ceramic, Chip
μ PG105	S band, low noise amplifier	f = 2.7 to 4.2 GHz Gp \geq 21 dB, Nf \leq 2.2 dB	• 16-pin ceramic
μ PG106	AGC amplifier	f = 100 kHz to 2.5 GHz Gp \geq 16 dB, GAGC \geq 25 dB	• 8-pin ceramic
μ PG107	SPDT switch	f = DC to 3.4 GHz Lins \leq 1.7 dB, tsw = 5 ns (typ.)	• 8-pin ceramic chip, Chip
μ PG110	Wide band, medium output amplifier	f = 2 to 8 GHz Po (1dB) \geq 10 dBm, Gp \geq 12 dB	• 4-pin ceramic chip, Chip
μ PG130	SPDT switch (for digital cellular)	f = 0.1 to 1 GHz, Po (1 dB) = 33 dBm Lins = 0.5 dB, Iso = 30 dB at 1 GHz	• 8-pin SOP • 8-pin SSOP
μ PG131	SPDT switch (for digital cordless)	f = 0.1 to 2 GHz, Po (1 dB) = 28 dBm Lins = 0.6 dB, Iso = 23 dB at 2 GHz	• 8-pin SOP • 8-pin SSOP
μ PG132	SPDT switch (for digital cordless)	f = 0.1 to 2 GHz, Po (1 dB) = 28 dBm Lins = 0.6 dB, Iso = 23 dB at 2 GHz	• 8-pin SSOP

■ Prescaler IC

Type number	Function	Features	Package
μ PG501	5 GHz, 1/4 static type prescaler	f = 1.5 to 5 GHz @ Pin = +10 dBm	• 8-pin ceramic, Chip
μ PG502	5 GHz, 1/2 static type prescaler	f = 1 to 5 GHz @ Pin = +10 dBm	• 8-pin ceramic, Chip
μ PG503	9 GHz, 1/4 dynamic type prescaler	f = 3.5 to 90 GHz @ Pin = +10 dBm	• 8-pin ceramic, Chip
μ PG504	9 GHz, 1/2 dynamic type prescaler	f = 2.0 to 9.0 GHz @ Pin = +10 dBm	• 8-pin ceramic, Chip
μ PG506	14 GHz, 1/8 dynamic type prescaler	f = 8 to 14 GHz @ Pin = 6 dBm	• 8-pin ceramic, Chip
μ PG508	14 GHz, 1/4 dynamic type prescaler	f = 8 to 14 GHz @ Pin = 6 dBm	• 8-pin ceramic, Chip

GaAs MCIC

Type number	Function	Features	Package
MC-5950	for Japan Analog f = 925 to 942 MHz	VDD = 5.8 V, Pout \geq 30.8 dBm Gp \geq 24 dB, η_T = 63%	Metal package 17 ∞ 12 ∞ 4 mm
MC-5951	for AMPS f = 824 to 849 MHz	VDD = 5.8 V, Pout \geq 30.5 dBm Gp \geq 24 dB, η_T = 63%	
MC-5952	for E-TACS f = 872 to 905 MHz	VDD = 5.8 V, Pout \geq 30.5 dBm Gp \geq 24 dB, η_T = 63%	
MC-5973	for AMPS f = 824 to 849 MHz	VDD = 4.6 V, Pout \geq 30.5 dBm Gp \geq 24 dB, η_T = 63%	
MC-5974	for E-TACS f = 872 to 905 MHz	VDD = 4.6 V, Pout \geq 30.5 dBm Gp \geq 24 dB, η_T = 63%	
MC-7620	for Japan Digital f = 940 to 956 MHz	VDD = 3.4 V, Pout = 31.2 dBm Gp \geq 25.2 dB, η_T = 45%	14.2 ∞ 11.3 ∞ 2.7 mm
MC-7621	for Japan Digital f = 1429 to 1453 MHz	VDD = 3.4 V, Pout = 31.2 dBm Gp \geq 20.2 dB, η_T = 45%	

Field Effect Transistor

■ **Low Noise GaAs FET Quick Reference Graph**

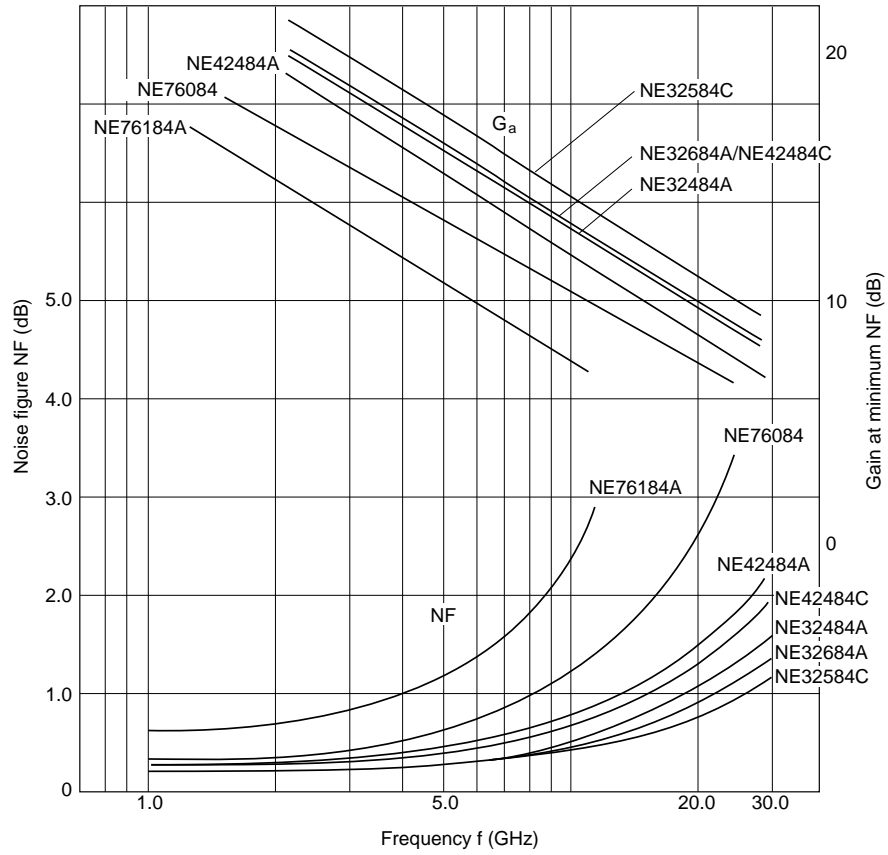

■ **Power GaAs FET Quick Reference Graph**

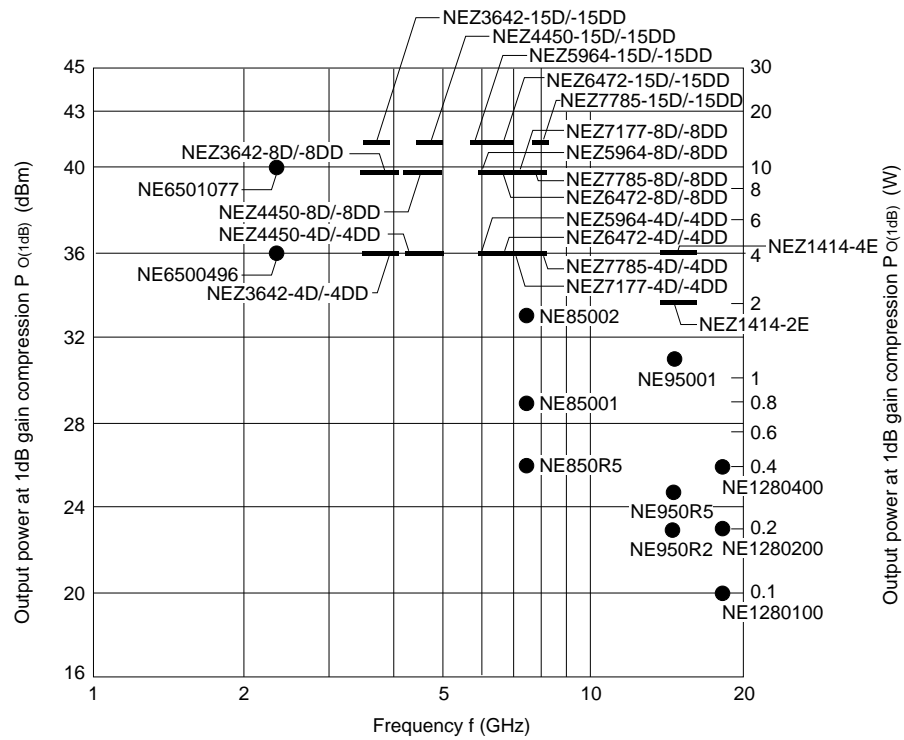

Transistor

■ **Low Noise Transistor Quick Reference Table**

Frequency (MHz) \ NF (dB)	2.5	3.5	4.0	5.0 or higher
200	————	————	2SC1044 2SC1426	————
500	————	2SC2148	2SC1275 2SC1424	————
2000	2SC3604	2SC3603	2SC2149	————
4000	2SC3587	————	————	2SC2150

■ **Power Transistor Quick Reference Table (for fixed radio station)**

Frequency \ Output power	10 W or higher
500 MHz or higher	2SC3660
800 MHz or higher	2SC3217-M 2SC3218-M 2SC3660A 2SK2396
900 MHz or higher	2SC3537 2SC3538 2SC3539 2SK2597
1900 MHz or higher	NEL2000 SERIES

■ **Power Transistor Quick Reference Table (for mobile and portable radio station)**

Frequency \ Output power	0.1 W or higher	1 W or higher	10 W or higher
500 MHz or higher	————	2SC2762	————
800 MHz or higher	————	2SC2850-KA/MA	2SC3282A 2SC3283A
1000 MHz or higher	2SC3817	2SC3541 2SC3818 2SC3819	2SC3542

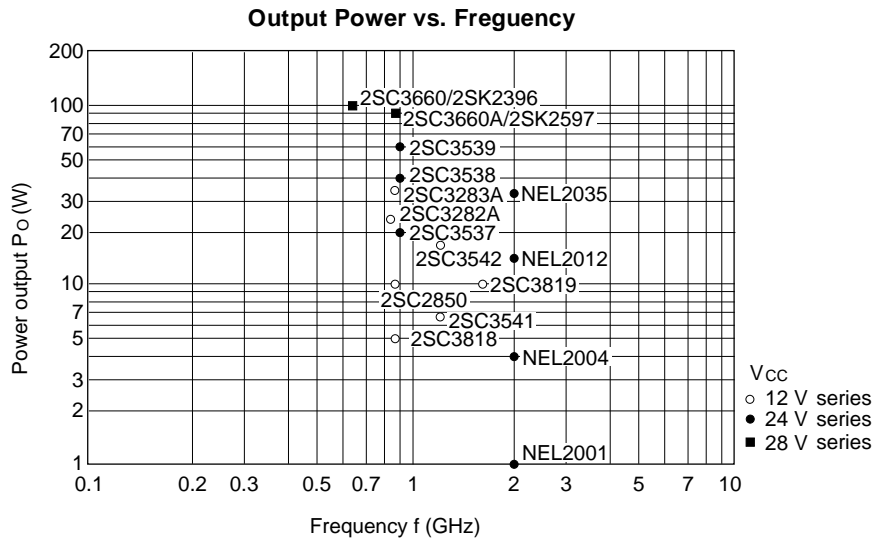

Diode**■ Schottky Barrier Diode**

Type number	Application	Electrical characteristics (TYP.)			
		V_R (V)	V_F (V)	I_F (mA)	C_t (pF)
ND487C1-3P	Double balanced modulator	–	~ 0.7	–	~ 1.0
ND487C2-3P	Double balanced modulator	–	~ 1.0	–	~ 1.0

MMIC

Type number	Function	Features	Package
μ PC1652	General purpose HF wide band amplifier	BW = 1.2 GHz, Gp = 18 dB, NF = 5.5 dB	• 8-pin SOP
μ PC1653		BW = 1.3 GHz, Gp = 18 dB, NF = 5.5 dB	• TO-72 CAN equivalent
μ PC1654		BW = 1.1 GHz, Gp = 19 dB, NF = 5.5 dB	• TO-12 CAN equivalent
μ PC1655		BW = 1.0 GHz, Gp = 18 dB, NF = 5.5 dB	• 8-pin DIP
μ PC1656		BW = 0.85 GHz, Gp = 19 dB, NF = 5.5 dB	• 8-pin DIP
μ PC1675		BW = 1.9 GHz, Gp = 12 dB, NF = 5.5 dB	• 4-pin mini-mold
μ PC1676		BW = 1.2 GHz, Gp = 22 dB, NF = 4.5 dB	• 4-pin mini-mold
μ PC1688		BW = 1.1 GHz, Gp = 21 dB, NF = 4 dB	• 4-pin mini-mold
μ PC1658	Low noise HF wide band amplifier	Gp = 31 dB/f = 100 MHz, GP = 17 dB/f = 500 MHz, (GAIN CONTROLABLE) NF = 1.5 dB/f = 100 MHz, NF = 2.0 dB/f = 500 MHz	• 8-pin CAN • 8-pin SOP • 8-pin DIP
μ PC1659	Ultra wide band amplifier	BW = 0.6 to 2.3 GHz, Gp = 19.5 dB, NF = 5 dB	• 4-pin CAN
		BW = 0.6 to 2.3 GHz, Gp = 23 dB, NF = 5 dB	• Ceramic
		BW = 0.7 to 1.75 GHz, Gp = 23 dB, NF = 5 dB	• 8-pin SOP
μ PC1663	Ultra high speed video amplifier	BW = 700 MHz/Ga = 20 dB, GAIN CONTROLABLE INPUT NOISE 3 μ Vr.m.s.	• 8-pin DIP • 8-pin SOP
μ PC1677	Wide band, medium output amplifier	BW = 1.8 GHz, Gp = 24 dB, NF = 6 dB, Po = 19.5 dBm	• 8-pin DIP
μ PC1678		BW = 2.0 GHz, Gp = 23 dB, NF = 6 dB, Po = 17.5 dBm	• 8-pin SOP
μ PC1668	High isolation IF amplifier	Ga = 14.5 dB, ISL = 55 dB/f = 70 MHz	• 8-pin DIP
μ PC1669		Ga = 10.5 dB, ISL = 55 dB/f = 70 MHz	• 8-pin DIP
μ PC1670		Ga = 7.0 dB, ISL = 55 dB/f = 70 MHz	• 8-pin DIP
μ PC2708	Middle power wide band amplifier	BW = 2.9 GHz, Po (sat) = +10 dBm, Gp = 15 dB	• 6-pin mini-mold
μ PC2709		BW = 2.3 GHz, Po (sat) = +11.5 dBm, Gp = 23 dB	
μ PC2710		BW = 1.0 GHz, Po (sat) = +13.5 dBm, Gp = 33 dB	
μ PC2711	Low noise wide band amplifier	BW = 2.9 GHz, Gp = 13 dB, NF = 5.0 dB	• 6-pin mini-mold
μ PC2712		BW = 2.6 GHz, Gp = 20 dB, NF = 4.5 dB	
μ PC2713		BW = 1.2 GHz, Gp = 29 dB, NF = 3.2 dB	
μ PC2714	Low power consumption wide band amplifier	BW = 1.8 GHz, Icc = 4.5 mA, Vcc = 3.4 V	• 6-pin mini-mold
μ PC2715		BW = 1.2 GHz, Icc = 4.5 mA, Vcc = 3.4 V	
μ PC2745		BW = 2.7 GHz, Icc = 7.5 mA, Vcc = 3.0 V, Gp = 12 dB	
μ PC2746		BW = 1.5 GHz, Icc = 7.5 mA, Vcc = 3.0 V, Gp = 19 dB	
μ PC2747	900 MHz Band	BW = 0.1 – 1.8 GHz, Icc = 5.0 mA, Vcc = 3.0 V, Gp = 12 dB	• 6-pin mini-mold
μ PC2748	Low noise amplifier	BW = 0.3 – 1.5 GHz, Icc = 6.0 mA, Vcc = 3.0 V, Gp = 19 dB	
μ PC2749	1.9 GHz Low noise amplifier	BW = 2.9 GHz, Icc = 6 mA, Gp = 16 dB, NF = 4 dB	• 6-pin mini-mold
μ PC2762	Medium power amplifier	BW = 2.9 GHz, Icc = 26.5 mA, Gp = 14.5 dB, P _{1dB} = 7 dBm	• 6-pin mini-mold
μ PC2763		BW = 2.4 GHz, Icc = 27 mA, Gp = 19.5 dB, P _{1dB} = 6.5 dBm	
μ PC2771		BW = 2.1 GHz, Icc = 36 mA, Gp = 21 dB, P _{1dB} = +11.5 dBm	
μ PC2723	1.1 GHz AGC amplifier	BW = 1.1 GHz, Gpmax. = 13 dB, GCR = 38 dB, Vcc = 5.0 V	• 6-pin mini-mold
μ PC2726	1.6 GHz differential amplifier	BW = 1.6 GHz, Icc = 11.5 mA, Gp = 15 dB, Vcc = 5.0 V	• 6-pin mini-mold
μ PC8104	1.9 GHz Up Converter + QPSK MOD	Vcc = 2.7 ~ 5.5 V, Icc = 28 mA	• 20-pin SSOP
μ PC8105	400 MHz QPSK MOD	Vcc = 2.7 ~ 5.5 V, Icc = 16 mA	• 16-pin SSOP
μ PC8110	900 MHz QPSK MOD	Vcc = 2.7 ~ 3.6 V, Icc = 24 mA	• 20-pin SSOP

MMIC

Power gain, noise figure vs. frequency

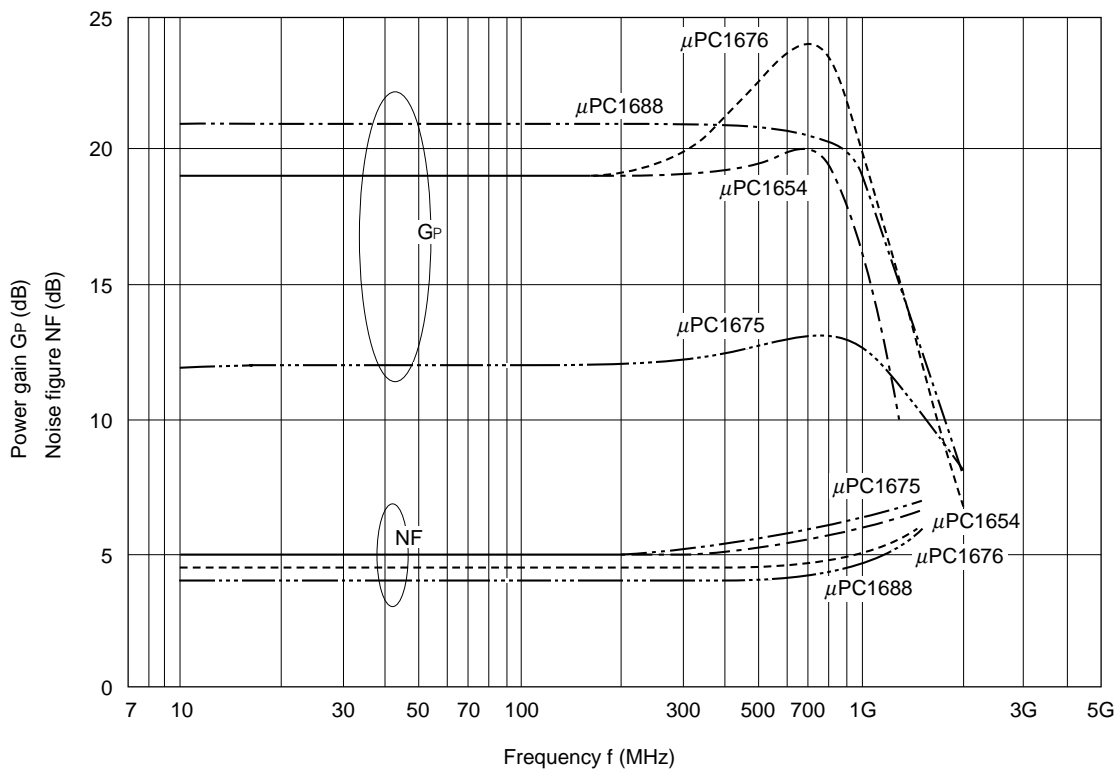
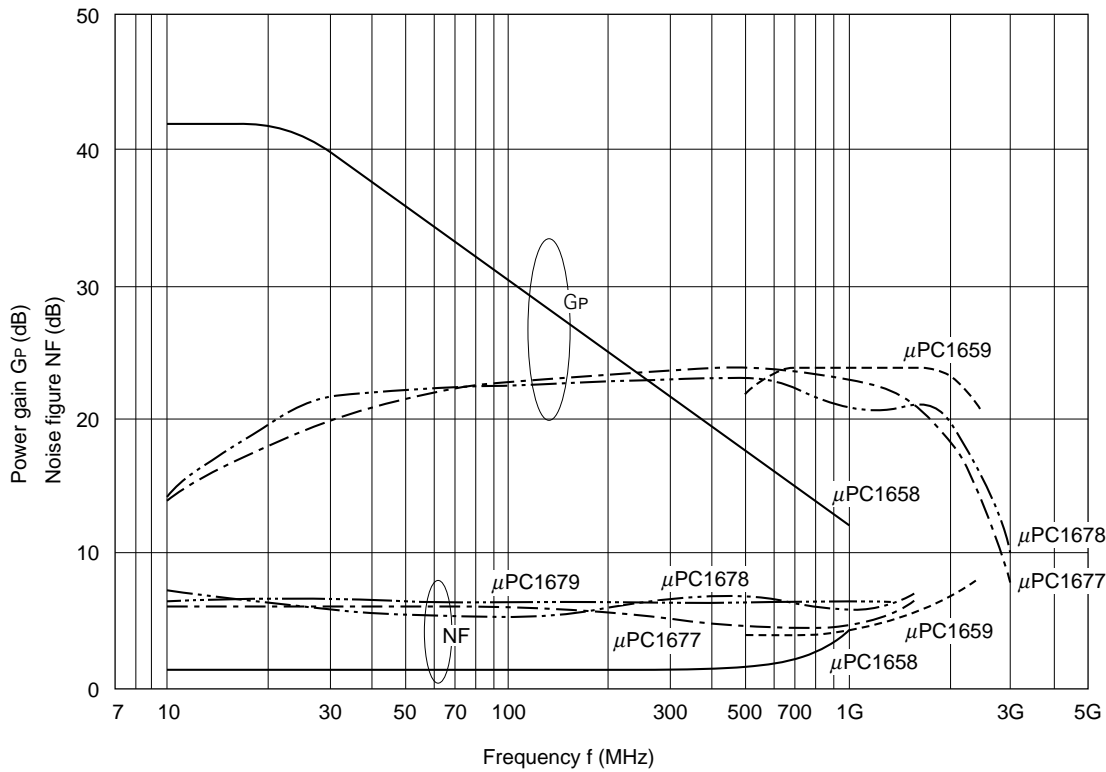

MMIC

Power gain, noise figure vs. frequency

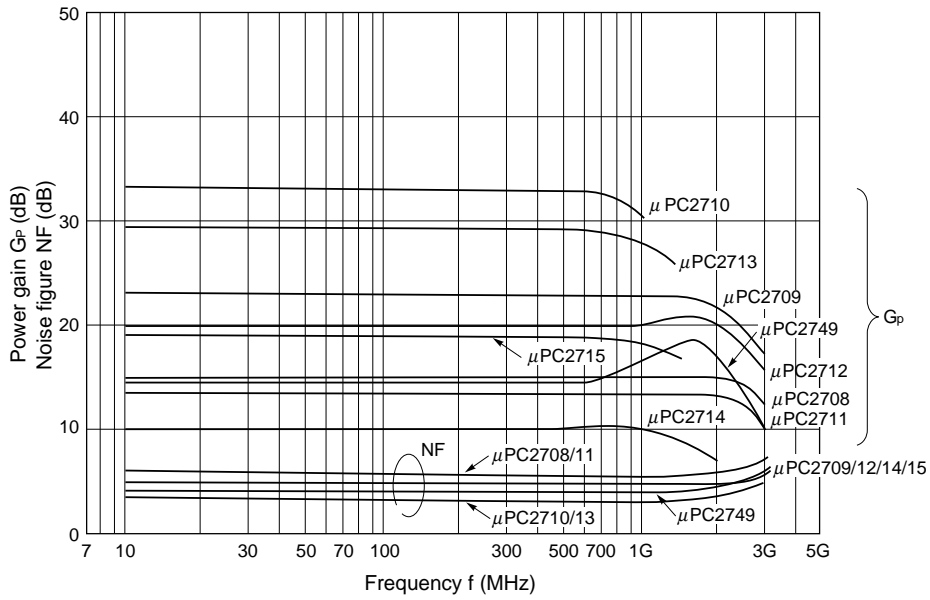

$P_{0(sat)}$ vs. frequency

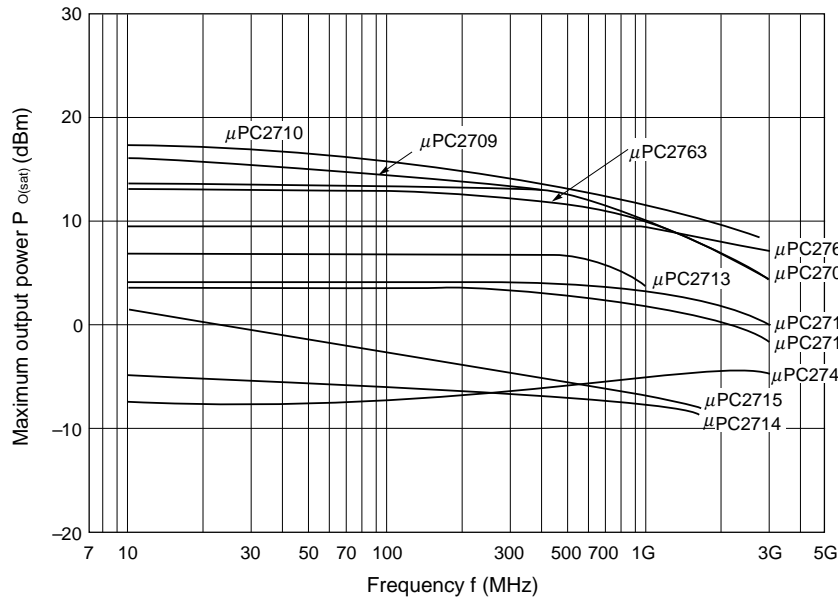

MMIC

Power gain, noise figure vs. frequency

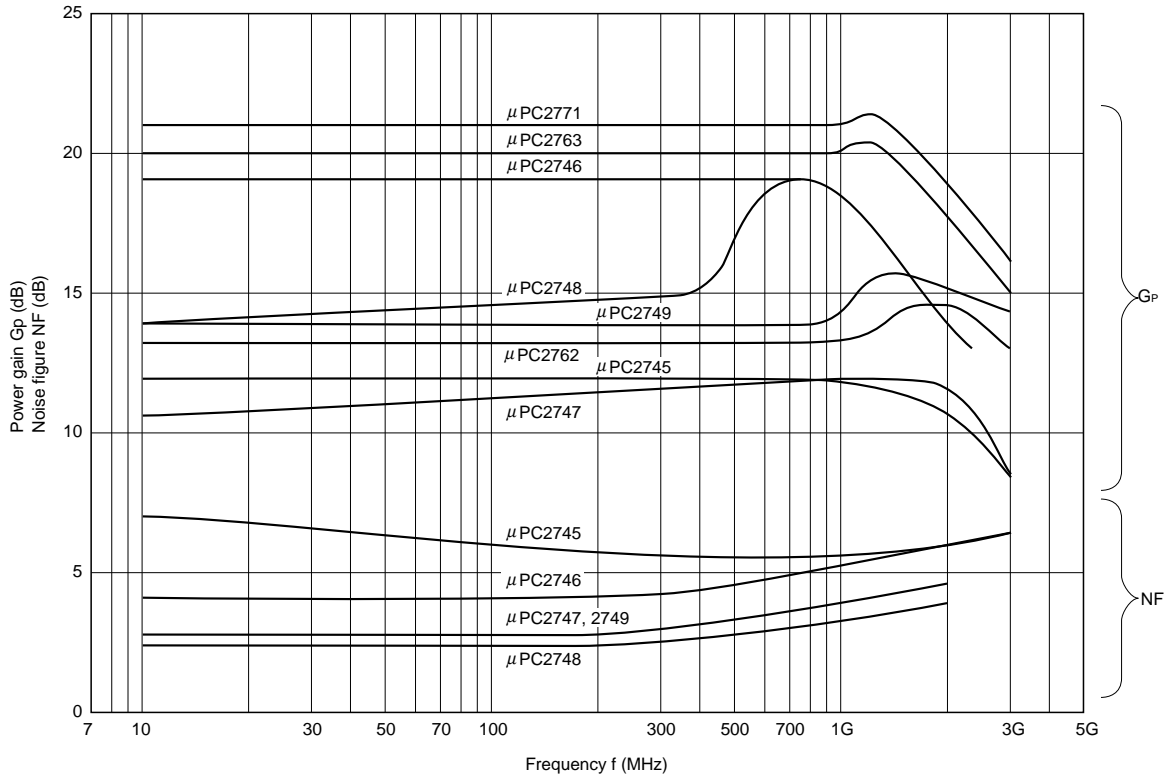

Po (sat) vs. frequency

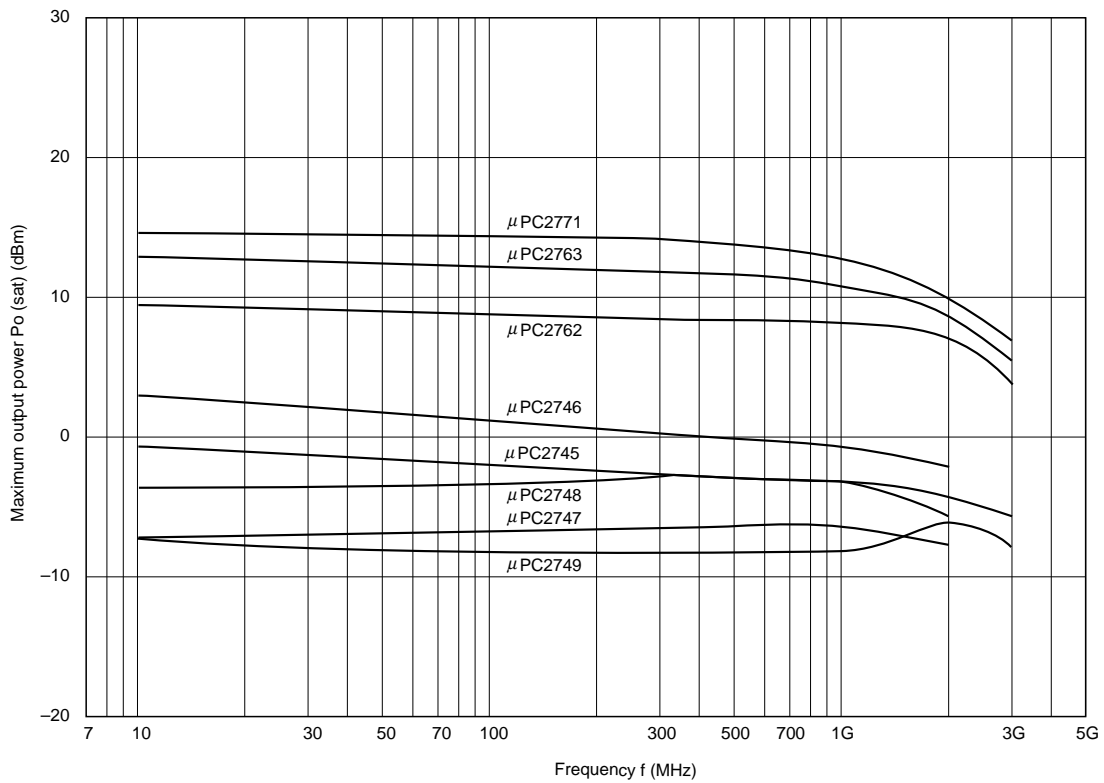

MMIC

Type number	Function	Features	Package
μ PC1685	Down converter (MIX/OSC/IF amplifier)	CG = 12 dB, NF = 12.5 dB, CM = 86 dB μ , @900 MHz	• 8-pin SOP
μ PC1686		CG = 20 dB, NF = 12 dB, CM = 94 dB μ , @470 MHz	• 8-pin SOP
μ PC1687		CG = 24 dB, NF = 10 dB, CM = 89 dB μ , @900 MHz	• 8-pin SOP
μ PC1673		CG = 23 dB, NF = 11.0 dB, CM = 92 dB μ , @470 MHz	• 16-pin SOP
μ PC1692		CG = 19 dB @470 MHz, CG = 24 dB @890 MHz	• 20-pin SOP
μ PC1694		CG = 18 dB, NF = 12.5 dB, CM = 103 dB μ , @470 MHz	• 14-pin SOP
μ PC2743		CG = 20 dB, @470 MHz, CG = 23 dB @890 MHz	• 20-pin SOP
μ PC2744		CG = 25 dB, @470 MHz, CG = 31 dB @890 MHz	• 20-pin SOP
μ PC2721		CG = 20 dB, NF = 11 dB, f _{RF} = 0.9 ~ 2.0 GHz	• 8-pin SOP
μ PC2722		CG = 15 dB, NF = 11 dB, f _{RF} = 0.9 ~ 2.0 GHz	
μ PC2731	AGC Amplifier + Down converter	CG = 14 dB, NF = 12 ~ 17 dB, f _{RF} = 0.9 ~ 2.0 GHz, GCR = 65 dB	• 20-pin SOP
μ PC2734	Down converter (MIX/OSC/IF Amp.)	CG = 10 ~ 13 dB, NF = 9 ~ 14 dB, f _{RF} = 0.9 ~ 2.1 GHz @f _{IF} = 402.8 MHz	• 20-pin SSOP
μ PC2757	Down converter (MIX/Lo Amp./IF Amp.)	f _{RF} BW = 2.0 GHz, CG = 15 dB, I _{CC} = 5.6 mA, V _{CC} = 3.0 V	• 6-pin mini-mold
μ PC2758		f _{RF} BW = 2.0 GHz, CG = 15 dB, I _{CC} = 11 mA, V _{CC} = 3.0 V	
μ PC2753	Down converter	f _{in} = DC ~ 400 MHz, CG _{MAX} = 79 dB, 3 V, 6.5 mA	• 20-pin SSOP
μ PC8106	Up converter	CG = 10 dB, I _{CC} = 9 mA, OIP ₃ = +7 dBm, 3 ~ 5 V	• 6-pin mini-mold
μ PC8109		CG = 7 dB, I _{CC} = 5 mA, OIP ₃ = +5 dBm, 3 ~ 5 V	
μ PC8100	Up/Down converter	Up converter + Down converter 1 chip IC	• 20-pin SSOP
μ PB584	Prescaler	1/2, f _{max.} = 2.5 GHz	• 8-pin SOP
μ PB585		1/4, f _{max.} = 2.5 GHz	• 8-pin SOP
μ PB586		1/256, 1/512, f _{max.} = 2.5 GHz	• 8-pin SOP
μ PB587		1/2, 1/4, 1/8 f _{max.} = 1 GHz	• 8-pin SOP
μ PB588		1/64, 1/128, f _{max.} = 2.5 GHz	• 8-pin SOP
μ PB581		1/2, f _{max.} = 2.8 GHz	• 8-pin CAN
μ PB582		1/4, f _{max.} = 2.8 GHz	• 8-pin CAN
μ PB1502		Prescaler with power save mode	f _{max.} = 1.7 GHz, 64/65, 128/129, V _{CC} = 3.0 V
μ PB1502(1)	f _{max.} = 2.0 GHz, 64/65, 128/129, V _{CC} = 3.0 V		
μ PB1504	Prescaler	f _{max.} = 1.1 GHz, 64/65, 128/129, 3 V, 1.9 mA	
μ PB1505		f _{max.} = 3.0 GHz, "256, "128, "64, 5 V, 14 mA	
μ PA101	Transistor array	MULTIPLAYER	• 14-pin ceramic • 8-pin SOP
μ PA102		2 DIFF AMP	• 14-pin ceramic • 14-pin SOP
μ PA103		3 Trs+1 PIAR Tr	• 14-pin ceramic • 14-pin SOP
μ PA104		ADDER	• 14-pin ceramic • 14-pin SOP

MMIC

[Down converter]

Conversion gain, noise figure vs. frequency

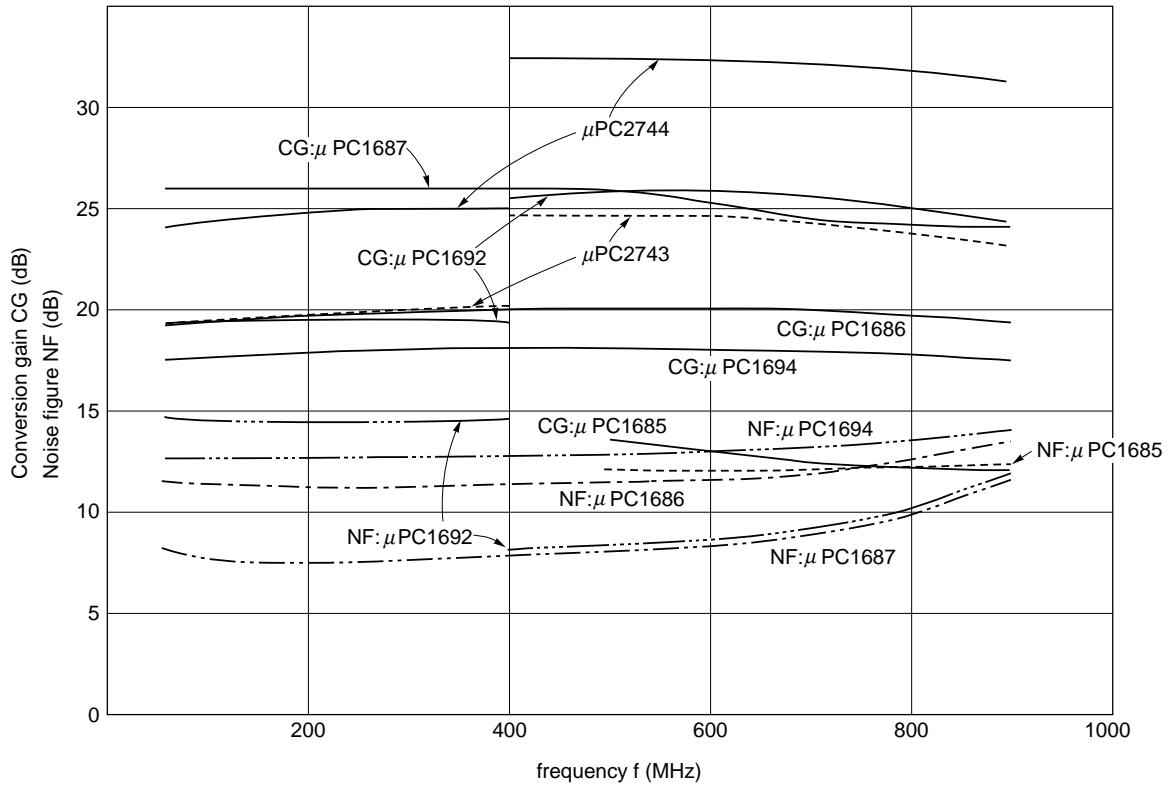

[Prescaler]

Input level vs. frequency

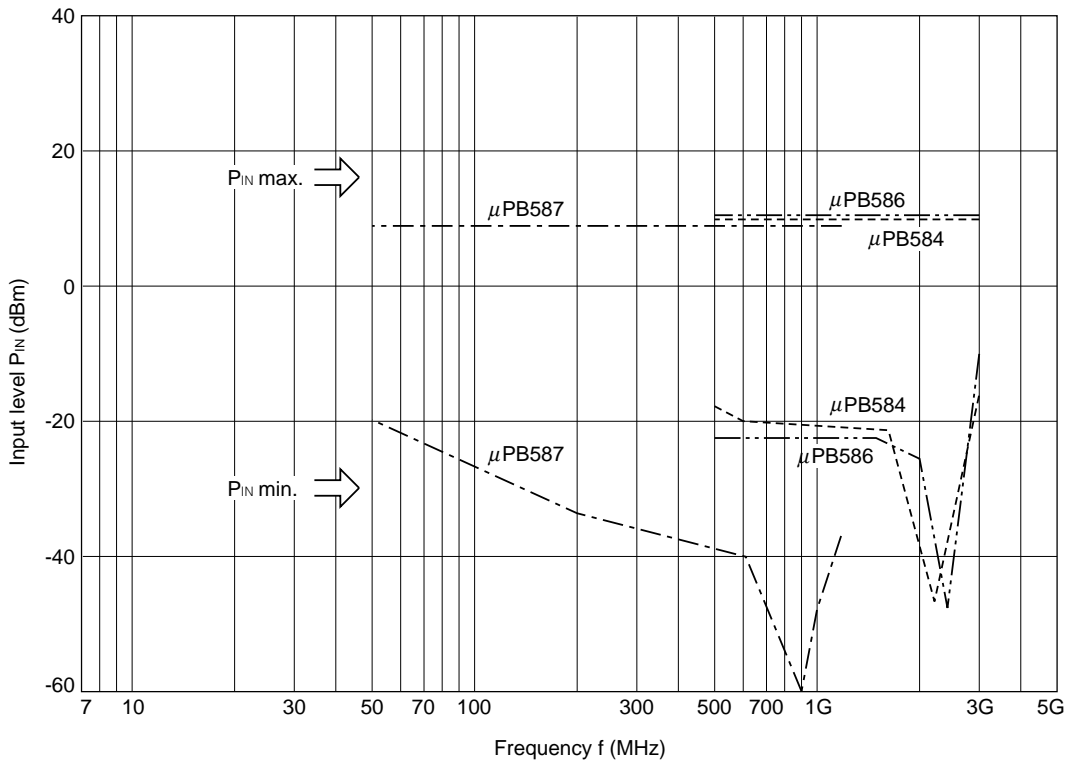

Transistor, FET

■ TV tuner

Application		Bi-polar transistor		Dual gate FET	
		Mini-mold (3-pin)	Small mini-mold (3-pin)	Mini-mold (4-pin)	Super mini-mold (4-pin)
VHF band	RF			3SK131 3SK222 3SK223 3SK230 3SK252	3SK242 3SK246 3SK243 3SK254
	MIX	2SC3545	2SC4182 2SC4184	3SK131	3SK242
	OSC	2SC3545	2SC4182 2SC4184		
UHF band	RF ($\lambda/4$)		2SC4183	3SK135A 3SK224 3SK231 3SK253	3SK244 3SK255
	RF ($\lambda/2$)			3SK134B	3SK245
	RF (GaAs FET)			3SK177 3SK206	
	MIX	2SC3545 2SC3841	2SC4183 2SC4185 2SC4184 2SC4186		
	OSC	2SC3545 2SC3841	2SC4182 2SC4184 2SC4185		

Application Block Diagram

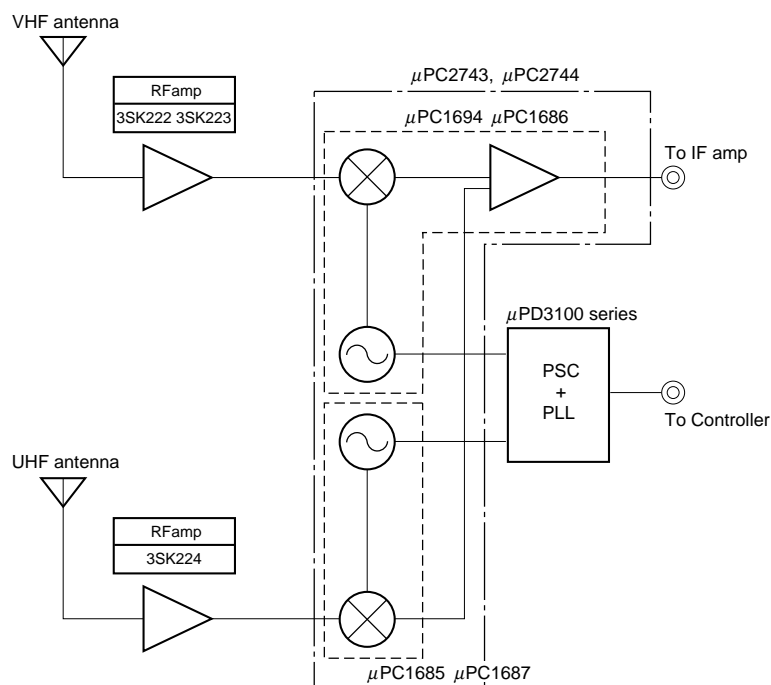

Transistor, FET

■ CATV converter

Application	Type number						Electrical characteristics	
	TO-92	Mini-mold		Super mini-mold		Ultrasuper mini-mold	f.T (GHz)	NF (dB)
		3-pin	4-pin	3-pin	4-pin	3-pin		
Pre Amp.	2SC3355	2SC3356	2SC4093	2SC4228	2SC5013	2SC5008	7 (20 mA)	1.1 (1 GHz)
	2SC2570A	2SC2351	2SC4092				5 (20 mA)	1.5 (1 GHz)
Buffer Amp.				2SC4185			2 (5 mA)	3 (0.5 GHz)
	2SC2570A	2SC2351	2SC4092				5 (20 mA)	1.5 (1 GHz)
1st IF Amp.	2SC3355	2SC3356	2SC4093	2SC4226	2SC5011	2SC5006	7 (20 mA)	1.1 (1 GHz)
	2SC2570A	2SC2351	2SC4092				5 (20 mA)	1.5 (1 GHz)
1st and 2nd OSC		2SC3545		2SC4184			1.8 (5 mA)	
				2SC4185			2 (5 mA)	
		2SC4568		2SC4570		2SC5005	5.5 (5 mA)	
		2SC4569		2SC4571		2SC5004	5 (5 mA)	
2nd IF Amp.			2SC4185			2 (5 mA)		

Application Block Diagram

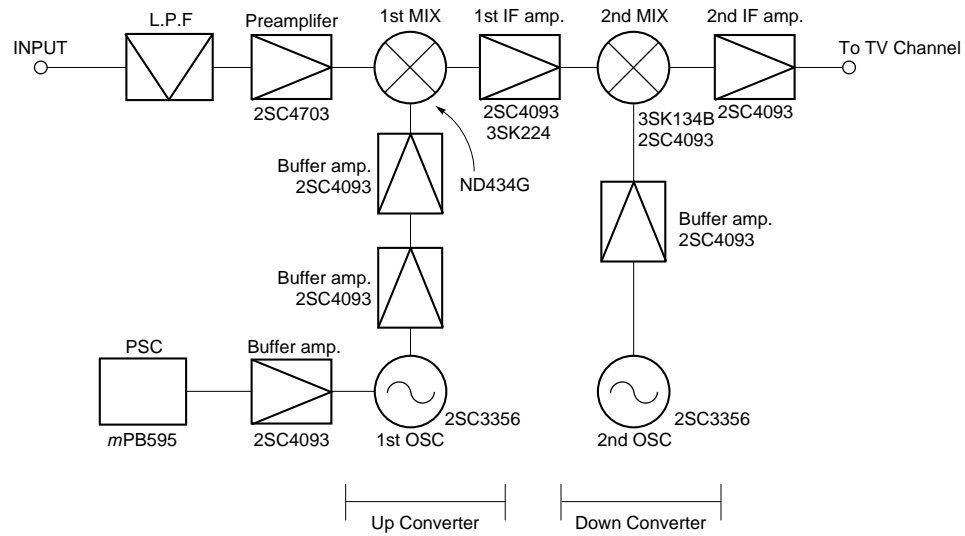

Diode

■ Mixer diode

Plastic mold package				Electrical characteristics (TYP.)		
4-pin mold (pair, each separate)	4-pin mini-mold (pair/PIN common)	6-pin mini-mold (QUAD)	8-pin SOP (QUAD)	V _F (V) (I _F = 1.0 mA)	I _F (mA) (V _F = 1.0 V)	C _t (pF)
ND414G-2	ND412G-2	ND487C1T/R1T	ND434G	~ 0.41	35 ~	1.0
ND413G-2	ND411G-2	ND487C2T/R2T	ND433G	~ 0.23	30 ~ (V _F = 0.5 V)	0.9

EMPTY PAGE

Optical Device

Fiber Optic Communication/Light Beam Application Device	180
• Laser Diodes	181
• Detectors	183
Light Emitting Element	185
• Infrared Ray Emitting Diode.....	185
Light Receiving Element	186
• Photo-transistor	186
• PIN Photo-diode	187
• Light Receiving IC	188
Photocoupler	189
Photointerrupter	191
Opto MOS FET Relay	194
Light Transmission Link	195
Infra-Red Link Unit	196

Fiber Optic Communication/Light Beam Application Devices

■ **Product map of optical communication/light beam application device**

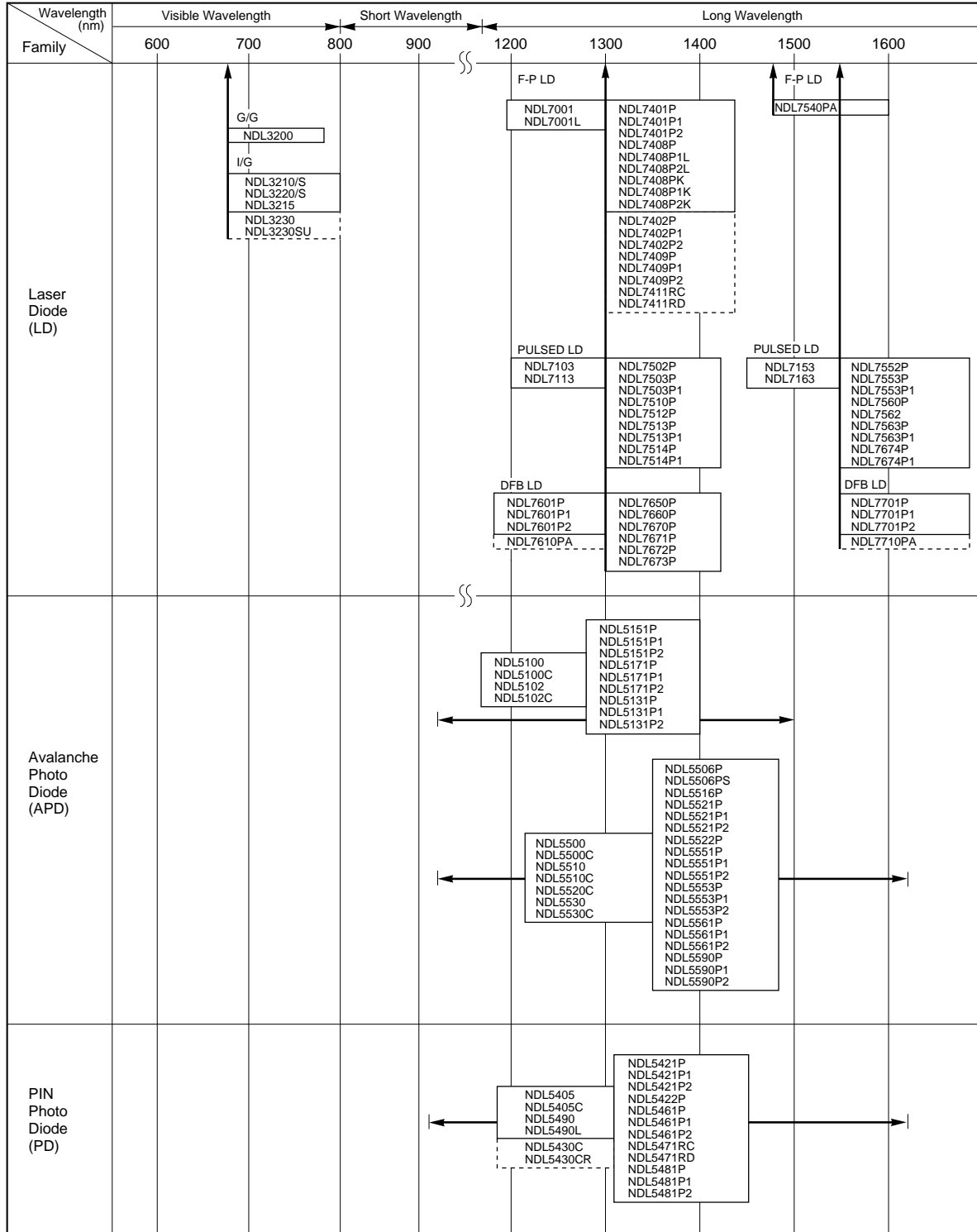

[] : Under development → : Mark wavelength or operating range

Modules are available with FC-PC or SC-PC connector.

Fiber Optic Communication/Light Beam Application Devices

Laser Diodes

■ Visible LD for Beam Applications

Type number	Absolute maximum ratings			Typical characteristics						Remarks
	Po/Pf (mW)	Tc (fC)	Tstg (fC)	Ith (mA)	Iop (mA)	Po/Pf (mW)	λc (nm)	θ⊥ (deg)	θΠ (deg)	
				TYP.	TYP.	TYP.	TYP.	TYP.	TYP.	
NDL3200	4	-10 to +50	-40 to +85	80	85	3	670	34	7	for BCR, Measurement etc.
NDL3210	6	-10 to +50	-40 to +85	40	60	5	670	34	9	for BCR, Measurement etc.
NDL3210S	5	-10 to +50	-40 to +85	40	60	4	670	34	9	for BCR, Measurement etc.
NDL3220	6	-10 to +60	-40 to +85	20	30	5	670	30	8	Low threshold current, High temperature operating
NDL3220S	6	-10 to +60	-40 to +85	20	30	5	670	30	8	Small package
NDL3215	10	-10 to +50	-40 to +85	50	60	10	670	31	8	for Long Distance BCR etc.
NDL3230*	35	-10 to +60	-40 to +85	50	100	30	685	20	9	for Magnetic Optical Disk, High Power application
NDL3230SU*	35	-10 to +60	-40 to +85	50	100	30	685	20	9	Small package
NDL3310*	4	-10 to +50	-40 to +85	70	80	3	650	34	9	Short wavelength

*: Under development

■ For Fiber Optic Communications

• Fabry Perrot LD

Type number	Absolute maximum ratings			Typical characteristics (25°C)					Remarks
	If (mA)	Tc (fC)	Tstg (fC)	Po/Pf (mW)	Ith (mA)	λp (nm)	σ*	tr/tf (ns)	
				TYP.	TYP.	TYP.	MAX.		
NDL7001	-	-40 to +85	-55 to +125	5.0	12	1310	1.0	0.5/0.5	with monitor PD, small package
NDL7001L	-	-40 to +85	-55 to +125	5.0	12	1310	1.0	0.5/0.5	with monitor PD, small package
NDL7401P/P1/P2	Ith+50	-40 to +85	-40 to +85	2.0	12	1310	1.3	0.5/0.5	with monitor PD
NDL7402P/P1/P2*	100	-40 to +85	-40 to +85	2.0	5	1310	1.5	0.5/0.5	with monitor PD
NDL7408PL/1L/2L	Ith+50	-40 to +85	-40 to +85	0.2	12	1310	1.3	0.5/0.5	with monitor PD
NDL7408PK/1K/2K	Ith+50	-40 to +85	-40 to +85	1.0	12	1310	1.3	0.5/0.5	with monitor PD
NDL7409P/P1/P2*	100	-40 to +85	-40 to +85	0.2	5	1310	1.5	0.5/0.5	with monitor PD
NDL7411RC/RD*	100	-40 to +85	-40 to +85	0.2	12	1310	1.3	0.5/0.5	with monitor PD, FC/SC receptacle

*: RMS (-20 dB)

*: Under development

• DFBLD

Type number	Absolute maximum ratings				Typical characteristics				Remarks
	If (mA)	Po/Pf (mW)	Tc (fC)	Tstg (fC)	Po/Pf (mW)	Ith (mA)	λp (nm)	tr/tf (ns)	
					TYP.	TYP.	TYP.		
NDL7601P/P1/P2	Ith+50	5	-20 to +85	-20 to +85	2.0	15	1310	0.5/0.5	with monitor PD
NDL7610PA*	150	5	-20 to +65	-40 to +70	2.0	20	1310	0.1/0.17	with monitor PD, isolator and TEC
NDL7701P/P1/P2	Ith+50	5	-20 to +85	-20 to +85	2.0	15	1550	0.5/0.5	with monitor PD
NDL7710PA*	150	5	-20 to +65	-40 to +70	2.0	25	1550	0.1/0.17	with monitor PD, isolator and TEC

*: Under development

Fiber Optic Communication/Light Beam Application Devices

Laser Diodes**■ For Analog Applications**

Type number	Absolute maximum ratings				Typical characteristics (25°C)						Remarks
	IF (mA)	Pf (mW)	Tc (fC)	Tstg (fC)	I _{th} (mA)	P _f (mW)	λ _p (nm)	RIN (dB/Hz)	CSO (dBc)	CTB (dBc)	
					TYP.	MIN.	TYP.	TYP.	TYP.	TYP.	
NDL7650P	150	15	-20 to +65	-40 to +70	20	4	1310	-155	-62	-70	with monitor PD, isolator and TEC
NDL7660P	150	15	-20 to +65	-40 to +70	20	6	1310	-155	-62	-70	with monitor PD, isolator and TEC
NDL7670P	150	15	-20 to +65	-40 to +70	20	8	1310	-155	-58	-65	with monitor PD, isolator and TEC
NDL7671P	150	15	-20 to +65	-40 to +70	20	10	1310	-155*	-58	-65	with monitor PD, isolator and TEC
NDL7672P	150	25	-20 to +65	-40 to +70	20	12	1310	-158	-60	-65	with monitor PD, isolator and TEC
NDL7673P	150	25	-20 to +65	-40 to +70	20	16	1310	-158	-60	-65	with monitor PD, isolator and TEC

*: MAX.

■ For EDFA Pumping and High Power OTDR Applications

Type number	Absolute maximum ratings			Typical characteristics						Remarks
	IFL (mA)	Tc (fC)	Tstg (fC)	I _{th} (mA)	I _{op} (mA)	P _o /P _f (mW)	λ _c (nm)	σ ^{*2} (nm)	tr/τf (ns)	
				TYP.	TYP.	TYP.	TYP.	MAX.	TYP.	
NDL7540PA	600	-20 to +70	-40 to +85	40	500	110	1480	8	-	with TEC, thermistor and m-PD
NDL7103	1200 ^{*3}	-40 to +70	-55 to +125	35	1000 ^{*3}	320 ^{*3}	1310 ^{*3}	7	1.5/1.7	ø5.6 can
NDL7113	600 ^{*3}	-40 to +70	-55 to +125	20	400 ^{*3}	175 ^{*3}	1310 ^{*3}	10	0.5/0.7	ø5.6 can
NDL7502P	1200 ^{*3}	-20 to +65	-40 to +70	35	1000 ^{*3}	190 ^{*3}	1310 ^{*3}	10	2/2 ^{*1}	with TEC
NDL7503P/P1	1200 ^{*3}	-20 to +60	-40 to +85	35	1000 ^{*3}	180 ^{*3}	1310 ^{*3}	10	1.5/1.7	
NDL7510P	600 ^{*3}	-20 to +65	-40 to +70	20	400 ^{*3}	55 ^{*3}	1310 ^{*3}	10	0.5/0.7	with TEC
NDL7512P	600 ^{*3}	-20 to +65	-40 to +70	20	400 ^{*3}	110 ^{*3}	1310 ^{*3}	10	1/1 ^{*1}	with TEC
NDL7513P/P1	600 ^{*3}	-20 to +60	-40 to +85	20	400 ^{*3}	110 ^{*3}	1310 ^{*3}	10	1/1 ^{*1}	
NDL7514P/P1	600 ^{*3}	-20 to +60	-40 to +85	20	400 ^{*3}	50 ^{*3}	1310 ^{*3}	10	1/1 ^{*1}	
NDL7153	1200 ^{*3}	-40 to +70	-55 to +125	45	1000 ^{*3}	240 ^{*3}	1550 ^{*3}	8	1.5/1.7	ø5.6 can
NDL7163	600 ^{*3}	-40 to +70	-55 to +125	30	400 ^{*3}	120 ^{*3}	1550 ^{*3}	10	0.5/0.7	ø5.6 can
NDL7552P	1200 ^{*3}	-20 to +65	-40 to +70	40	1000 ^{*3}	125 ^{*3}	1550 ^{*3}	10	2/2 ^{*1}	with TEC
NDL7553P/P1	1200 ^{*3}	-20 to +60	-40 to +85	45	1000 ^{*3}	145 ^{*3}	1550 ^{*3}	10	2/2 ^{*1}	
NDL7560P	600 ^{*3}	-20 to +65	-40 to +70	20	400 ^{*3}	30 ^{*3}	1550 ^{*3}	10	0.5/0.7	with TEC
NDL7562P	600 ^{*3}	-20 to +65	-40 to +70	40	400 ^{*3}	75 ^{*3}	1550 ^{*3}	10	1/1 ^{*1}	with TEC
NDL7563P/P1	600 ^{*3}	-20 to +60	-40 to +85	40	400 ^{*3}	80 ^{*3}	1550 ^{*3}	10	1/1 ^{*1}	
NDL7564P/P1	600 ^{*3}	-20 to +60	-40 to +85	40	400 ^{*3}	40 ^{*3}	1550 ^{*3}	10	1/1 ^{*1}	

*1 : MAX.

*2 : RMS (-20 dB)

*3 : Pulse conditions; measurement of wavelength

pulse width = 1 μs, duty = 1%

measurement of optical output power

pulse width = 10 μs, duty = 1% (modules)

pulse width = 1 μs, duty = 1% (ø5.6 can)

Fiber Optic Communication/Light Beam Application Devices

Detectors■ **PIN Photo Diodes**

Type number	Absolute maximum ratings				Detecting area size (μm)	Typical characteristics								Remarks	Package
	I_F (mA)	I_R (mA)	T_C (°C)	T_{stg} (°C)		I_b (nA)		C_t (pF)		S (A/W)		f_c (GHz)	t_r / t_f (ns)		
						V_R (V)	TYP.	V_R (V)	TYP.	λ (nm)	TYP.				
NDL5405	10	0.5	-40 to +85	-55 to +150	$\phi 80$	5	0.1	5	1.0	1300 0.89 1550 1.00	-	0.3		CAN Package	
NDL5405C	10	0.5	-40 to +85	-55 to +150	$\phi 80$	5	0.1	5	1.0	1300 0.89 1550 1.00	-	0.3		Chip on carrier	
NDL5430C/CR	10	3.0	-40 to +85	-55 to +150	$\phi 30$	5	5.0*	-	-	1300 0.89 1550 1.00	2.5	-	for 10 Gb/s CR: With Resistance	Chip on carrier	
NDL5471RC/RD	10	0.5	-40 to +85	-40 to +85	$\phi 120$	5	0.1	5	1.1	1300 0.89 1550 1.00	1.5	-	RC: FC receptacle RD: SC receptacle	Receptacle module	
NDL5461P/P1/P2	10	-	-40 to +85	-40 to +85	$\phi 80$	5	0.1	5	1.0	1300 0.89 1550 0.94	2.5	-	P: Without flange P1: With flat mount flange P2: With vertical flange	Coaxial module (With MMF)	
NDL5481P/P1/P2	10	-	-40 to +85	-40 to +85	$\phi 80$	10	0.1	10	0.7	1300 0.85	2.5	-	for analog applications P: Without flange P1: With flat mount flange P2: With vertical flange	Coaxial module (With SMF)	
NDL5421P/P1/P2	10	0.5	-40 to +85	-40 to +85	$\phi 50$	5	0.1	5	1.0	1300 0.89 1550 0.94	2.5	-	P: Without flange P1: With flat mount flange P2: With vertical flange	Coaxial module (With MMF)	
NDL5490	10	0.5	-40 to +85	-40 to +85	$\phi 50$	5	2.0*	-	-	1330 0.78	1.0	-	With Pre-AMP $\bar{P} = -24$ dBm typ. 1 Gb/s	CAN Package	
NDL5490L	10	0.5	-40 to +85	-40 to +85	$\phi 50$	5	2.0*	-	-	1330 0.78	1.0	-	With Pre-AMP $\bar{P} = -24$ dBm typ. 1 Gb/s	CAN Package with ball lens	
NDL5422P	-	0.5	-40 to +70	-40 to +85	$\phi 50$	5	0.1	-	-	1330 0.89 1550 1.00	2.5	-	With Pre-AMP $\bar{P} = -23$ dBm typ. 2.5 Gb/s	BFY Package (6-pin) (With MMF)	

*: MAX.

Fiber Optic Communication/Light Beam Application Devices

Detectors

■ **Avalanche Photo Diodes**

Type	Type number	Absolute maximum ratings				Detecting area size (μm)	Typical characteristics								Remarks	Package
		I _F (mA)	I _R (mA)	T _C (fC)	T _{sig} (fC)		V _{(BR)R} (V)	I _D (nA)		S (A/W)		M	f _c (GHz)	t _r / t _f (ns)		
								TYP.	V _R (V)	TYP.	λ (nm)					
Ge-APD	NDL5100	50	0.5	-40 to +60	-55 to +125	ø100	48*2	V _{(BR)R} ≈0.9	200	1300	0.78	40	-	0.5		CAN Package
	NDL5100C	50	0.5	-40 to +60	-55 to +125	ø100	48*2	V _{(BR)R} ≈0.9	200	1300	0.78	40	-	0.5		Chip on carrier
	NDL5102	50	0.5	-40 to +60	-55 to +125	ø30	35	V _{(BR)R} ≈0.9	80	1300	0.78	50	-	0.3		CAN Package
	NDL5102C	50	0.5	-40 to +60	-55 to +125	ø30	35	V _{(BR)R} ≈0.9	80	1300	0.78	50	-	0.3		Chip on carrier
	NDL5171P /P1/P2	50	0.5	-40 to +85	-40 to +85	ø100	48*2	V _{(BR)R} ≈0.9	200	1300	0.84	40	-	0.5	P: Without flange P1: With flat mount flange P2: With vertical flange	Coaxial module (With MMF)
	NDL5151P /P1/P2	50	0.5	-40 to +85	-40 to +85	ø50	35	V _{(BR)R} ≈0.9	150	1300	0.84	50	-	0.4	P: Without flange P1: With flat mount flange P2: With vertical flange	Coaxial module (With MMF)
	NDL5131P /P1/P2	50	0.5	-40 to +85	-40 to +80	ø30	35	V _{(BR)R} ≈0.9	80	1300	0.84	40	-	0.3	P: Without flange P1: With flat mount flange P2: With vertical flange	Coaxial module (With SMF)
InGaAs-APD	NDL5510	10	0.5	-40 to +70	-55 to +100	ø80	75	V _{(BR)R} ≈0.9	8	1300 1550	0.89 1.00	40	0.7	-		CAN Package
	NDL5510C	10	0.5	-40 to +70	-55 to +100	ø80	75	V _{(BR)R} ≈0.9	8	1300 1550	0.89 1.00	40	0.7	-		Chip on carrier
	NDL5500	10	0.5	-40 to +70	-55 to +100	ø50	70	V _{(BR)R} ≈0.9	5	1300 1550	0.89 1.00	40	1.0	-		CAN Package
	NDL5500C	10	0.5	-40 to +70	-55 to +100	ø50	70	V _{(BR)R} ≈0.9	5	1300 1550	0.89 1.00	40	1.0	-		Chip on carrier
	NDL5520C	10	0.5	-40 to +70	-55 to +100	ø50	55	V _{(BR)R} ≈0.9	5	1300 1550	0.89 1.00	40	2.5	-	for 2.5 Gb/s (ø50)	Chip on carrier
	NDL5530	10	0.5	-40 to +85	-55 to +100	ø30	70	V _{(BR)R} ≈0.9	5	1300 1550	0.94 0.96	40	2.5	-		CAN Package
	NDL5530C	10	0.5	-40 to +85	-55 to +100	ø30	70	V _{(BR)R} ≈0.9	5	1300 1550	0.89 1.00	40	1.0	-		Chip on carrier
	NDL5561P /P1/P2	10	0.5	-40 to +85	-40 to +85	ø80	75	V _{(BR)R} ≈0.9	8	1300 1550	0.94 0.96	40	1.0	-	P: Without flange P1: With flat mount flange P2: With vertical flange	Coaxial Module (With MMF GI-62.5)
	NDL5551P /P1/P2	10	0.5	-40 to +85	-40 to +85	ø50	70	V _{(BR)R} ≈0.9	5	1300 1550	0.94 0.96	40	1.0	-	P: Without flange P1: With flat mount flange P2: With vertical flange	Coaxial module (With MMF)
	NDL5521P /P1/P2	10	0.5	-40 to +85	-40 to +85	ø50	70	V _{(BR)R} ≈0.9	5	1300 1550	0.94 0.96	40	2.5	-	for 2.5 G Applications P: Without flange P1: With flat mount flange P2: With vertical flange	Coaxial module (With MMF)
	NDL5553P /P1/P2	10	0.5	-40 to +85	-40 to +85	ø50	70	M = 20	50	1300 1550	0.89 0.94	20*1	-	0.5*2	for OTDR Applications P: Without flange P1: With flat mount flange P2: With vertical flange	Coaxial module (With MMF)
	NDL5516P	10	0.5	-20 to +55	-40 to +85	ø80	75	V _{(BR)R} ≈0.9 I _C =1.1A @ 55°C	2	1300 1550	0.89 1.00	40	0.7	-	for OTDR Applications With TEC ΔT ≥ 45K	DIP module (With MMF GI-62.5)
	NDL5506P /PS	10	0.5	-20 to +55	-40 to +85	ø50	70	V _{(BR)R} ≈0.9 I _C =1.1A @ 55°C	2	1300 1550	0.89 1.00	40	1.0	-	for OTDR Applications With TEC ΔT ≥ 45K P: With MMF, PS: With SMF	DIP module
	NDL5590P /P1/P2	-	0.5	-40 to +85	-40 to +85	ø50	70	V _{(BR)R} ≈0.9	5	1300 1550	0.94 0.96	-	1.0	-	With Pre-AMP P = -36 dBm typ. 622 Mb/s P: Without flange P1: With flat mount flange P2: With vertical flange	Coaxial module (With MMF)
	NDL5522P	-	0.5	-40 to +70	-40 to +85	ø50	55	V _{(BR)R} ≈0.9	5	1300 1550	0.89 1.00	-	2.5	-	With Pre-AMP P = -33 dBm typ. 2.5 Gb/s	BFY Package (6-pin) (With MMF)







*1: MIN.
*2: MAX.

Light Emitting Element

■ Infrared Ray Emitting Diode

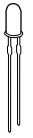
Type number	Materials	Features	Absolute maximum ratings ($T_a = 25\text{ }^\circ\text{C}$)			Electrical characteristics ($T_a = 25\text{ }^\circ\text{C}$)		Package (package No.)
			P (mW)	I_F (mA)	V_F TYP. (V) ($I_F = 300\text{ mA}$)	λ_p TYP. (nm) ($I_F = 30\text{ mA}$)	P_o TYP. (mW) ($I_F = 30\text{ mA}$)	
SE301A	GaAs	High output, high reliability	150	100	1.2 ($I_F = 50\text{ mA}$)	940	6 ($I_F = 50\text{ mA}$)	P1
SE302A	GaAs	Ultra miniature double end	75	50	1.2	940	1.5	P2
SE303	GaAs	High output, narrow beam	150	100	1.25 ($I_F = 50\text{ mA}$)	940	3 ($I_F = 50\text{ mA}$)	P4
SE303A-C	GaAs	High output, wide beam	150	100	1.25 ($I_F = 50\text{ mA}$)	940	8 ($I_F = 50\text{ mA}$)	P4
SE304	GaAs	Horizontal output	100	50	1.2	940	1.5	P5
SE306	GaAs	Horizontal output with lens	100	50	1.1 ($I_F = 10\text{ mA}$)	940	0.5 mW/sr ($I_F = 10\text{ mA}$)	P6
SE307-C	GaAs	High output, narrow beam	150	100	1.25 ($I_F = 50\text{ mA}$)	940	30 mW/sr ($I_F = 50\text{ mA}$)	P4
SE308	GaAs	Small horizontal output with lens	100	50	1.1 ($I_F = 20\text{ mA}$)	940	0.85 mW/sr ($I_F = 20\text{ mA}$)	P7
SE310	GaAs	Vertical high output with lens	150	60	1.25 ($I_F = 50\text{ mA}$)	940	11 mW/sr ($I_F = 50\text{ mA}$)	P3
SE313	GaAs	High output with moderately wide beam	150	100	1.25 ($I_F = 50\text{ mA}$)	940	25 mW/sr ($I_F = 50\text{ mA}$)	P4
SE314	GaAs	Miniature Type	75	50	1.2 ($I_F = 10\text{ mA}$)	940	0.2 ($I_F = 10\text{ mA}$)	P5
SE316(L)	GaAs	Ultra miniature double end	75	50	1.2 ($I_F = 10\text{ mA}$)	940	0.4 ($I_F = 10\text{ mA}$)	P14
SE1003-C	GaAlAs on GaAs	Ultra high output with wide beam	150	100	1.27 ($I_F = 50\text{ mA}$)	950	20 mW/sr ($I_F = 50\text{ mA}$)	P4
SE1103	GaAlAs	High speed (3 MHz)	150	50	1.6 ($I_F = 50\text{ mA}$)	890	7 mW/sr ($I_F = 50\text{ mA}$)	P4

Package (package appearance)

Package	TO-18 glass	Small resin mold	Domed resin mold	Square resin mold			
							
Package No.	P1	P2 P3	P4	P5	P6	P7	

Light Receiving Element

■ **Photo-transistor**

Type number	Features	Absolute maximum ratings (T _a = 25 °C)			Electrical characteristics (T _a = 25 °C)			Package (package No.)
		P _c (mW)	I _c (mA)	V _{CEO} (V)	I _{CEO} (nA) V _{CE} = 10 V I _C = 0	V _{CE} (sat) (V) (L = 1000 lx)	I _L (μA) V _{CE} = 2 V I _C = 100 lx	
PH101	Small Darlington connection	100	50	20	~ 500 (V _{ce} = 15 V)	~ 1.5	10mA ~	P8
PH102	Small High speed response	100	40	30	~ 200	~ 0.3	50 ~	P8
PH103	Darlington connection	100	50	30	~ 400	~ 1.5	2 mA ~	P9
PH104	High speed response	100	40	30	~ 100	~ 0.3	20 ~	P9
PH105	φ4.8 lens package	150	50	30	~ 200	~ 0.3	500 ~ (V _{CE} = 10 V)	P4
PH106	Horizontal type with lens High speed response	100	40	30	~ 100	~ 1.3	60 ~	P6
PH107	Horizontal type with lens Darlington connection	100	50	30	~ 400	~ 1.5	10 mA ~	P6
PH108	Small horizontal type with lens High speed response	100	40	30	~ 100	~ 0.3 (H = 5 m W/cm*)	0.3 mA ~ V _{CE} = 5 V I _C = 0.5 mW/cm*	P7
PH108A	Horizontal type with lens High speed response, visible ray cut resin	100	40	30	~ 100	~ 0.3 (H = 5 m W/cm*)	0.2mA ~ V _{CE} = 5 V I _C = 0.5 mW/cm*	P7
PH109	Horizontal type with lens Darlington connection	100	50	30	~ 400	~ 1.2	10 mA ~	P7
PH110	Horizontal type with lens High sensitivity, visible ray cut resin	100	40	30	~ 100	~ 0.3 (H = 500 μ W/sr)	200 ~ V _{CE} = 5 V I _C = 50 μW/cm*	P3
PH114	Miniature type	75	25	30	~ 100	~ 0.4	40 ~	P5
PH116(L)	Ultra miniature double end	75	25	30	~ 100	~ 0.4	40 ~	P14

*: Measured with infrared of λ_P = 940 nm (peak emission wavelength)

Package (package appearance)

Package	TO-18 glass	Small resin mold	Small resin mold	Domed resin mold	Square resin mold	Square resin mold	Square resin mold
Package No.	P1	P2	P3	P4	P5	P6	P7

Package	Small resin mold	Square	Square	Square	Square	Square	Square
Package No.	P8	P9	P10	P11	P12	P13	P14

Light Receiving Element

PIN Photo-diode
■ PIN photo-diode for remote control application

Type number	Features	Absolute maximum ratings (T _a = 25 fC)			Electrical characteristics (T _a = 25 fC)		Package (package No.)
		V _R (V)	P _C (mW)	Sensitivity (nA/lx) (V _R = 5 V)	I _D (nA) (V _R = 10 V)	t _r (ns) (R _L = 1 kΩ)	
PH302	Mold case	32	150	50 ^{*1} (6 (μA) ^{*2})	~ 30	50	P10
PH302C	Mold case Visible ray cut filter	32	150	32 ^{*1} (5 (μA) ^{*2})	~ 30	50	P10
PH309	Small mold case with lens Visible ray cut resin	32	150	32 ^{*1} (5 (μA) ^{*2})	~ 10	30	P12
PH310	Small mold case with lens Visible ray cut resin	32	150	32 ^{*1} (5 (μA) ^{*2})	~ 10	30	P13
PH320	Small mold case with lens Visible ray cut resin	32	150	4.3 (μA) ^{*2}	~ 10	30	P13

*1: Light source color temperature 2854K

*2: Sensitivity (@H = 0.1 mW/cm²) for infrared ray (λ_P = 940 nm)
■ PIN photo-diode for CD, VD

Type number	Absolute maximum ratings (T _a = 25 fC)				Electrical-optical typical characteristics (T _a = 25 fC)							Remarks
	I _F (mA)	I _L (mA)	V _R (V)	T _{stg} (fC)	I _D		C _t		S		t _r , t _f (ns)	
					V _R (V)	(nA)	Focus (pF)	Tracking (pF)	λ (nm)	(A/W)		
PH315	10	5	20	-40 to +100	15	4	1.6	1.9	780	0.52	1	6 unit PD

Light Receiving Element

Light Receiving IC■ **Light Receiving IC with built-in Schmidt trigger circuit**

Type number	Features	Absolute maximum ratings ($T_a = 25\text{ }^\circ\text{C}$)		Electrical characteristics ($T_a = 25\text{ }^\circ\text{C}$)		Package
		V_{CC} (V)	I_{OL} (mA)	Threshold irradiance ($\mu\text{W}/\text{cm}^2$) ($V_{CC} = 5\text{ V}$) $\lambda = 940\text{ nm}$	V_{OL} (V) $I_{OL} = 16\text{ mA}$ $V_{CC} = 5\text{ V}$	
PH502HR	Active high (without incidence: low level) Internal pull-up resistor	17	50	~ 50	~ 0.4	• 3-pin square resin mold
PH502HC	Active high (without incidence: low level) Open-collector output	17	50	~ 50 ($R_L = 280\ \Omega$)	~ 0.4 ($R_L = 280\ \Omega$)	• 3-pin square resin mold
PH502LR	Active low (without incidence: high level) Internal pull-up resistor	17	50	~ 50	~ 0.4	• 3-pin square resin mold
PH502LC	Active low (without incidence: high level) Open-collector output	17	50	~ 50 ($R_L = 280\ \Omega$)	~ 0.4 ($R_L = 280\ \Omega$)	• 3-pin square resin mold
PH514HR	Active high (without incidence: low level) Internal pull-up resistor	17	50	~ 500	~ 0.4	• 3-pin square resin mold
PH514HC	Active high (without incidence: low level) Open-collector output	17	50	~ 500 ($R_L = 280\ \Omega$)	~ 0.4 ($R_L = 280\ \Omega$)	• 3-pin square resin mold
PH514LR	Active low (without incidence: high level) Internal pull-up resistor	17	50	~ 500	~ 0.4	• 3-pin square resin mold
PH514LC	Active low (without incidence: high level) Open-collector output	17	50	~ 500 ($R_L = 28\ \Omega$)	~ 0.4 ($R_L = 280\ \Omega$)	• 3-pin square resin mold
PH516HR(L)	Active high (without incidence: low level) Internal pull-up resistor	17	50	~ 60	~ 0.4	• Ultra miniature double end
PH516HC(L)	Active high (without incidence: low level) Open-collector output	17	50	~ 60 ($R_L = 280\ \Omega$)	~ 0.4 ($R_L = 280\ \Omega$)	• Ultra miniature double end
PH516LR(L)	Active low (without incidence: high level) Internal pull-up resistor	17	50	~ 60	~ 0.4	• Ultra miniature double end
PH516LC(L)	Active low (without incidence: high level) Open-collector output	17	50	~ 60 ($R_L = 280\ \Omega$)	~ 0.4 ($R_L = 280\ \Omega$)	• Ultra miniature double end

■ **PIN photo-diode with built-in amplifier for CD**

Type number	Absolute maximum ratings ($T_a = 25\text{ }^\circ\text{C}$)				Light-electrical typical characteristics ($T_a = 25\text{ }^\circ\text{C}$)						Remarks
	V_{CC} (V)	I_{CC} (mA)	P_D (mW)	T_{stg} ($^\circ\text{C}$)	V_{CC} (V)	V_o		S		f_r (MHz)	
						Focus (mV)	Tracking (mV)	λ (nm)	(A/W)		
PH522	11	–	100	–30 to +85	5	110	500	780	–	8	6 unit PD with internal amplifier
PH525	11	–	100	–40 to +85	5	340	710	780	–	8	6 unit PD with internal amplifier

Photocoupler

Type number	Features	BV ₁₋₂	I _F (mA)	V _{CEO} (V)	CTR (%)	Package	Remarks		
PS1001		1 kV _{DC}	60	30	20 ~	TO-5	Single transistor output		
PS2501-1 to -4	High isolation voltage	5 kVr.m.s.	80	80	80 to 600	• 4- to 16-pin DIP (multi)	Darlington transistor output		
PS2502-1 to -4			50	40	100 to 400		Single transistor output		
PS2503-1 to -4			±80	80	80 to 600		AC input Single transistor output		
PS2505-1 to -4				40	200 ~		AC input Darlington transistor output		
PS2506-1 to -4									
PS2521-1 to -4	High isolation voltage	5 kVr.m.s.	150	80	20 to 80	• 4-pin DIP	Single transistor		
PS2525-1 to -4	Large current input		±150				Darlington transistor		
PS2532-1 to -4	High isolation voltage	5 kVr.m.s. (3.75 kVr.m.s.)	80	300	1500 to 6500	• 4- to 16-pin DIP (multi)	Darlington transistor		
PS2533-1 to -4				350	1500 to 6500		Single transistor		
PS2561-1 to -2	High isolation voltage (VDE0884 Approved)			80	80		80 to 400	Darlington transistor	
PS2562-1 to -2			200 ~				Single transistor		
PS2565-1 to -2			±80	80	80 to 400		Darlington transistor		
PS2566-1 to -2					200 ~		Darlington transistor		
PS2601	High isolation voltage		80	80	80 to 600	• 6-pin DIP	Single transistor With base		
PS2602							Single transistor Without base		
PS2603							40	200 ~	Darlington transistor With base
PS2604									Darlington transistor Without base
PS2605			±80	80	80 to 600		AC input Single transistor With base		
PS2606							AC input Single transistor Without base		
PS2607			40	200 ~	AC input Darlington transistor With base				
PS2608					AC input Darlington transistor Without base				
PS2621	High isolation voltage Large current input		150	80	20 to 50	• 6-pin DIP	Single transistor With base		
PS2622			Single transistor Without base						
PS2625			±150				80	20 to 50	AC input Single transistor With base
PS2626									AC input Single transistor Without base
PS2633	High isolation voltage			300	1000 to 15000		Darlington transistor Without base		
PS2634	High V _{CEO}			Darlington transistor Without base					
PS2651	High isolation voltage (VDE0884 Approved)		80	80	50 to 400	• 6-pin DIP (lead forming)	Single transistor With base		
PS2652							Single transistor Without base		
PS2653				40	200 ~		Darlington transistor With base		
PS2654							Darlington transistor Without base		

Photocoupler

■ SOP Photocoupler

Type number	Features	BV ₁₋₂	I _F (mA)	V _{CEO} (V)	CTR(%)	Package	Remarks		
PS2701-1,-2,-4	High isolation voltage	2.5 kVr.m.s.	50	40	50 to 300	• SOP (2.54 pitch)	Single transistor		
PS2702-1,-2,-4					200 ~		Darlington transistor		
PS2703-1,-2,-4					50 to 400		Single transistor		
PS2705-1,-2,-4			±50	50 to 300	AC input, Single transistor				
PS2706-1,-2,-4				200 ~	AC input, Darlington transistor				
PS2707-1,-2,-4				50 to 400	AC input, Single transistor				
PS2732-1,-2,-4	High isolation voltage		50	300	1500 to 6500			Darlington transistor	
PS2733-1,-2,-4	High V _{CEO}			350					
PS2801-1	High isolation voltage		2.5 kVr.m.s.	50	80		80 to 600	• SOP (1.27 pitch)	Single transistor
PS2802-1					40		200 ~		Darlington transistor
PS2805-1				±50	80		80 to 600		AC input, Single transistor
PS2806-1					40		200 ~		AC input, Darlington transistor
PS2801-4		50		80	80 to 600	Single transistor			
PS2802-4				40	200 ~	Darlington transistor			
PS2805-4				±50	80	80 to 600	AC input, Single transistor		
PS2806-4				50	40	200 ~	AC input, Darlington transistor		

■ High Speed Photocoupler

Type number	Features	BV ₁₋₂	I _F (mA)	V _{CC} (V)	CTR (%)	Package	Remarks
PS2041	High speed response	2.5 kVr.m.s.	25	-0.5 to 15	15 ~	• 6-pin DIP	Photodiode + transistor
PS2043						• 8-pin DIP	
PS2044						• 5-pin SOP	
PS2741					10 ~		
PS8601	5 kVr.m.s.	5	35	15 ~		• 8-pin DIP	Photodiode + transistor without base
PS8602							Photodiode + transistor

■ High Speed Photocoupler

Type number	Features	BV ₁₋₂	I _F (mA)	V _{CC} (V)	t _{PHL} , t _{PLH} (ns)	Package	Remarks
PS9601	High speed response (IC output)	5 kVr.m.s.	20	7	50 (TYP.)	• 8-pin DIP	—
PS9701		2.5 kVr.m.s.	30		50 (TYP.)	• 5-pin SOP	

■ Inverter Control Photocoupler

Type number	Features	BV ₁₋₂	I _F (mA)	V _{CC} (V)	I _{o2} (A)	Package	Remarks
PS9634	High output, high noise immunity	5 kVr.m.s.	30	18	0.8	• 8-pin DIP	Built-in amplifier

■ IGBT Drive Photocoupler

Type number	Features	BV ₁₋₂	I _F (mA)	V _{CC} (V)	t _{PHL} , t _{PLH} (μs)	Package	Remarks
PS9636	High output	5 kVr.m.s.	20	35	0.5 (TYP.)	• 8-pin DIP	Built-in amplifier

Photocoupler

■ Photo TRIAC Photocoupler

Type number	Features	BV ₁₋₂	I _{FT} (mA)	V _{DRM} (V)	I _T (mA)	Package	Remarks	
PS3601	High isolation voltage	5 kVr.m.s.	~ 5	600	0.1	• 5-pin DIP	without zerocross	
PS3602				400			with zerocross	
PS3611*				600				
PS3612*				400				
PS3701	Small size (SOP type)	3.75 kVr.m.s.	~ 5	600	0.1	• 4-pin SOP	without zerocross	
PS3702				400			with zerocross	
PS3711*	High isolation voltage						600	
PS3712*							400	
PS3901	High output power (1.2 A) High isolation voltage	5 kVr.m.s.	~ 5	600	1.2	• 10-pin DIP	without zerocross	
PS3911*				600			with zerocross	
PS3912*				400				

* : Under development

Photointerrupter

PS4XXX Family (phototransistor type)

■ PS40XX - PS45XX family

Type number	Current transfer ratio			Features
	CTR (%)	I _F (mA)	V _{CE} (V)	
PS4001	20 ~	10	2	Light receiving window: 1mm [■] , Darlington transistor output
PS4003	15 ~	10	2	Darlington transistor output
PS4005, PS4007 PS4009, PS4010	20 ~	10	2	Darlington transistor output
PS4008	0.5 ~	10	2	Single transistor output
PS4011	20 ~	10	2	Light receiving window: 1mm [■] , Darlington transistor output
PS4015	3 ~	10	2	Light receiving window: 1mm [■] , Single transistor output
PS4016	270 ~	10	2	Light receiving window: 0.5mm Darlington transistor output
PS4501	0.5 ~	10	2	Light receiving window: 0.5mm Slit, Single transistor output
PS4502	200 ~	10	2	Light receiving window: 0.5mm Slit, Darlington transistor output
PS4503A	270 ~	10	2	Light receiving window: 0.5mm Slit, Darlington transistor output
PS4504A	270 ~	10	2	Light receiving window: 0.5mm Slit, Darlington transistor output
PS4506	2.5 ~	20	2	Light receiving window: 0.5mm Slit, Single transistor output

PS4501

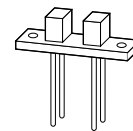

Photointerrupter

■ PS46XX family

Type number	Current transfer ratio			Features
	CTR (%)	I _F (mA)	V _{CE} (V)	
PS4601	1.5 ~	5	2	Small all-in-one type (2.5 mm thick) Single transistor output
PS4602	1.5 ~	5	2	Small all-in-one type (PS4601 with light shield case) Single transistor output
PS4602(1)	1.5 ~	5	2	Small all-in-one type (PS4602 short lead type) Single transistor output
PS4651	40 ~	5	2	Small all-in-one type (2.5 mm thick) Darlington transistor output
PS4652	40 ~	5	2	Small all-in-one type (PS4651 with light shield case) Darlington transistor output
PS4652(1)	40 ~	5	2	Small all-in-one type (PS4652 short lead type) Darlington transistor output

PS4601



■ PS47XX Family

Type number	Current transfer ratio			Features
	CTR (%)	I _F (mA)	V _{CE} (V)	
PS4701 PS4702	5 ~	5	0.6	Miniature type (4 x 4 x 4 mm) Single transistor output Light receiving window: 0.3mm slit
PS4703	1.3 ~	10	0.6	Snap-in type Single transistor output Light receiving window: 0.5mm slit
PS4704	1.0 ~	10	0.6	Miniature type (3.8 x 4 x 4 mm) Single transistor output Light receiving window: 0.15mm slit
PS4751 PS4752	100 ~	5	2	Miniature type (4 x 4 x 4 mm) Darlington transistor output Light receiving window: 0.3mm slit

PS4701

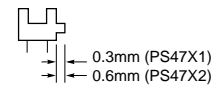

Photointerrupter

PS5XXX Family (photo IC type)

■ PS50XX Family

Type number	Threshold current			Features
	(mA)	V _{CC} (V)	R _L (Ω)	
PS5001HR	(I _{FLH}) ~ 5	5	-	Internal Schmidt trigger circuit Active high type Internal pull-up resistor Light receiving window: 0.5mm slit (equivalent to 0.5mm ²)
PS5002HR				
PS5003HR				
PS5001HC	(I _{FLH}) ~ 5	5	280	Internal Schmidt trigger circuit Active high type Open-collector output Light receiving window: 0.5mm slit (equivalent to 0.5mm ²)
PS5002HC				
PS5003HC				
PS5001LR	(I _{FLH}) ~ 5	5	-	Internal Schmidt trigger circuit Active low type Internal pull-up resistor Light receiving window: 0.5mm slit (equivalent to 0.5mm ²)
PS5002LR				
PS5003LR				
PS5001LC	(I _{FLH}) ~ 5	5	280	Internal Schmidt trigger circuit Active low type Open-collector output Light receiving window: 0.5mm slit (equivalent to 0.5mm ²)
PS5002LC				
PS5003LC				

PS5001HR

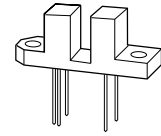

■ PS57XX Family

Type number	Threshold current			Features
	(mA)	V _{CC} (V)	R _L (Ω)	
PS5701HR PS5702HR	(I _{FLH}) ~ 5	5	-	Miniature type (4 ∞ 4 ∞ 4 mm, Light receiving window: 0.3 mm) Internal Schmidt trigger circuit Active high type/internal pull-up resistor
PS5701HC PS5702HC	(I _{FLH}) ~ 5	5	280	Miniature type (4 ∞ 4 ∞ 4 mm, Light receiving window: 0.3 mm) Internal Schmidt trigger circuit Active high type/open-collector output
PS5701LR PS5702LR	(I _{FLH}) ~ 5	5	-	Miniature type (4 ∞ 4 ∞ 4 mm, Light receiving window: 0.3 mm) Internal Schmidt trigger circuit Active low type/internal pull-up resistor
PS5701LC PS5702LC	(I _{FLH}) ~ 5	5	280	Miniature type (4 ∞ 4 ∞ 4 mm, Light receiving window: 0.3 mm) Internal Schmidt trigger circuit Active low type/open-collector output
PS5732LR-R	(I _{FLH}) ~ 3	3	-	Miniature type (4 ∞ 4 ∞ 4 mm, Light receiving window: 0.3 mm) Low supply voltage (1.4 to 7 V) Internal Schmidt trigger circuit Active low type/internal pull-up resistor

PS5701HR



0.3 mm (PS5701XX)
0.6 mm (PS5702XX)

■ PS6XXX family (reflective type sensor)

Type number	Light current			Features
	I _L (μA)	I _F (mA)	V _{CE} (V)	
PS6001A	100 ~ (Metal reflection surface)	≒ 30	5	Single transistor output
PS6002A	400 ~ (White reflection surface)	10	2	Single transistor output Long detection distance (effective detection distance: 3 to 10 mm) Visible ray cut resin used (light receiving side)

PS6002A



Opto MOS FET Relay

Type number	Features	V _{I-O} (V)	V _{BOUT} (V)	I _L (mA)	R _{on} (Ω)	Working I _F (mA)	Package	Remarks
PFA101A	General use	1500	60	150	10.0	10	6-pin DIP	AC/DC
PFA112A			100	200	6.0			
PFA113A			100	350	2.5			
PFA122A			200	250	5.0			
PFA141A			400	150	10.0			
PFD102A			60	200	5.0			DC
PFD112A			100	250	3.0			
PFD114A			100	450	1.3			
PFD123A			200	350	2.5			
PFD142A			400	200	5.0			
PFA112B			High sensitivity	2500	100			200
PFA113B	100	350			2.5			
PFA122B	200	250			5.0			
PFA141B	400	150			10.0			
PFA160B	600	100			50.0			
PFD112B	100	250			3.0	DC		
PFD114B	100	450			1.3			
PFD123B	200	350			2.5			
PFD142B	400	200			5.0			
PFD161B	600	140			25.0			
PFA141C	High isolation voltage	5000			400	150	10.0	10
PFA160C			600	90	50.0	DC		
PFD142C			400	200	5.0			
PFD161C			600	120	25.0			
PFA141E		2500	400	120	50.0	5	6-pin DIP	AC/DC
PFA201A	General use 2-channel	1500	60	100	10.0	5	8-pin DIP	AC/DC
PFA213A			100	300	2.5			
PFA222A			200	200	5.0			
PFA260A			600	90	50.0			

Light Transmission Link

Type number	Absolute maximum rating ($T_a = 25\text{ }^\circ\text{C}$)		Electrical characteristics ($T_a = 25\text{ }^\circ\text{C}$)			
	V_{cc} (V)	T_{opt} ($^\circ\text{C}$)	Transmission capacity (bps, NRZ)	Transmission distance (m)	I_{cc} (mA) TYP.	Light output (dBm)
PLX101 series			DC to 6M	0.2 to 5		
PLT101	-0.5 to +7	-20 to +70			15 ($R_L = 8.2\text{ k}\Omega$)	-21 to -15
PLR101	-0.5 to +7	-20 to +70			25	
PLX102 series			DC to 6M	0.2 to 5		
PLT102	-0.5 to +7	-20 to +70			15 ($R_L = 8.2\text{ k}\Omega$)	-21 to -15
PLR102	-0.5 to +7	-20 to +70			25	
PLX104 series			DC to 6M	0.2 to 5		
PLT104	-0.5 to +7	-20 to +70			15 ($R_L = 8.2\text{ k}\Omega$)	-21 to -15
PLR104	-0.5 to +7	-20 to +70			25	
PLX1101 series			DC to 6M	0.1 to 50		
PLT1101	-0.5 to +7	-20 to +70			15 ($R_L = 8.2\text{ k}\Omega$)	-21 to -11
PLR1101	-0.5 to +7	-20 to +70			25	
PLX201 series			DC to 6M	0.1 to 50		
PLD201A	-0.5 to +7	-20 to +70				-21 to -11

Configuration

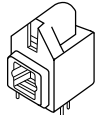
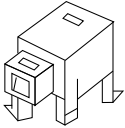
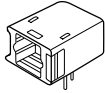
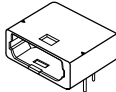
Link name	Optical transmission module	Optical receive module	Optical transmission/receive module	Remarks
PLX101 series	PLT101 	PLR101	—	BS tuner TV with BS tuner Audio equipment
PLX102 series	PLT102 	PLR102	—	
PLX104 series	PLT104 	PLR104*	—	
PLX1101 series	PLT1101 	PLR1101	—	FA, OA, measurement and test equipment
PLX201 series	—	—	PLD201A 	

*: Under development

Infra-Red Link Unit

Conform to IrDA Ver. 1.0/Ver. 2.0

Type number	Absolute maximum rating (T _A = 25 fC)		Electrical characteristics (T _A = 25 fC)			Package (package No.)
	V _{CC} (V)	T _{opt} (fC)	Data rate (bps)	Transmission distance (m)	Viewing angle (°C)	
PLS4001L1	-0.5 to +7.0	0 to +70	2.4 k to 4 M	~ 1.0	30	P1
PLS4001L2						P2

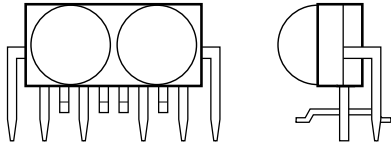
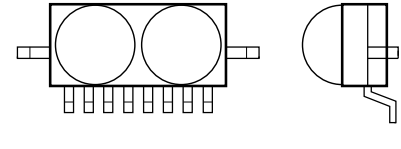
Package				
Package No.	P1		P2	

Packages

Plastic DIP	198
Ceramic DIP	201
Plastic SOP	202
Plastic TSOP	204
Plastic QFP	205
QFJ	208
Ceramic PGA	209
Plastic SIP	210
Plastic V-DIP	211
Plastic ZIP	211
Plastic Mold.....	212

Note: Only typical packages are shown here.



Plastic DIP (Dual In-line Package)

Units in mm

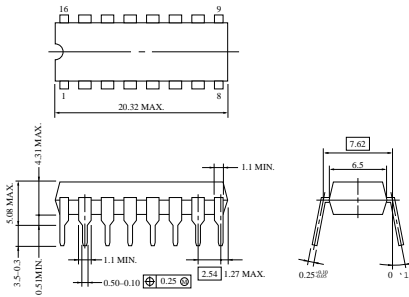
<p>8-pin plastic DIP (300mil)</p> <p>P8C-100-300B, C</p>	<p>14-pin plastic DIP (300mil)</p> <p>P14C-100-300B1</p>
<p>14-pin plastic shrink DIP (300mil)</p> <p>P14C-70-300B</p>	<p>16-pin plastic DIP (300mil)</p>  <p>P16C-100-300B-1</p>
<p>16-pin plastic shrink DIP (300mil)</p> <p>P16C-70-300B</p>	<p>16-pin plastic DIP with TAB (300mil)</p> <p>P16CT-100-300B</p>
<p>18-pin plastic DIP (mil)</p> <p>P18C-100-300A, C</p>	<p>18-pin plastic shrink DIP (300mil)</p> <p>P18C-70-300B</p>

Plastic DIP (Dual In-line Package)

Units in mm

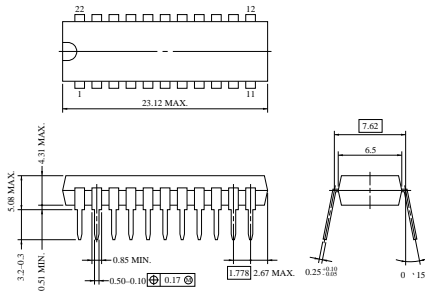
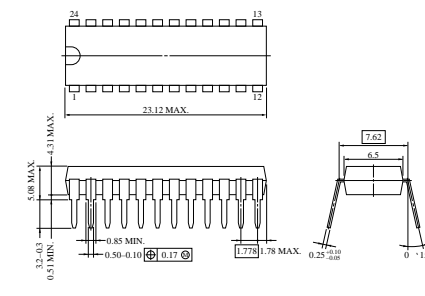
<p>20-pin plastic DIP (300mil)</p> <p style="text-align: center;">P20C-100-300A, C</p>	<p>20-pin plastic shrink DIP (300mil)</p> <p style="text-align: center;">P20C-70-300B</p>
<p>22-pin plastic DIP (300mil)</p> <p style="text-align: center;">P22C-100-300WA</p>	<p>22-pin plastic shrink DIP (300mil)</p>  <p style="text-align: center;">S22C-70-300B-1</p>
<p>24-pin plastic DIP (300mil)</p> <p style="text-align: center;">P24C-100-300A</p>	<p>24-pin plastic shrink DIP (300mil)</p>  <p style="text-align: center;">S24C-70-300B-1</p>
<p>28-pin plastic DIP (400mil)</p> <p style="text-align: center;">P28C-100-400</p>	<p>28-pin plastic shrink DIP (400mil)</p> <p style="text-align: center;">S28C-70-400B</p>

Plastic DIP (Dual In-line Package)

Units in mm

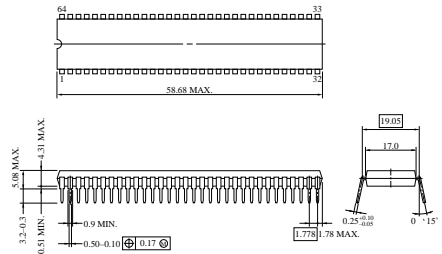
<p>30-pin plastic shrink DIP (400mil)</p> <p style="text-align: right;">S30C-70-400B</p>	<p>40-pin plastic DIP (600mil)</p> <p style="text-align: right;">P40C-100-600A</p>
<p>40-pin plastic shrink DIP (600mil)</p> <p style="text-align: right;">P40C-70-600A</p>	<p>42-pin plastic DIP (600mil)</p> <p style="text-align: right;">P42C-100-600A, B</p>
<p>42-pin plastic shrink DIP (600mil)</p> <p style="text-align: right;">P42C-70-600A</p>	<p>48-pin plastic DIP (600mil)</p> <p style="text-align: right;">P48C-100-600A</p>
<p>48-pin plastic shrink DIP (600mil)</p> <p style="text-align: right;">P48C-70-600B</p>	<p>64-pin plastic shrink DIP (750mil)</p>  <p style="text-align: right;">P64C-70-750A, C-1</p>

Ceramic DIP (Dual In-line Package)

Units in mm

<p>8-pin ceramic DIP (300mil)</p> <p>Top view: 10.16 MAX. Side view: 30.43, 5.08 MAX., 3.80, 0.89 MIN., 1.42 MIN., 0.51 MIN., 2.54, 1.27 MAX., 0.46-0.05, 0.25, 0.25. End view: 7.62, 6.30, 0.25-0.05, 0°-15°.</p> <p>P8DH-100-300A,B-1</p>	<p>14-pin ceramic DIP (300mil)</p> <p>Top view: 20.32 MAX. Side view: 30.43, 5.08 MAX., 3.80, 0.51 MIN., 1.42 MIN., 2.54, 2.54 MAX., 0.46-0.05, 0.25, 0.25. End view: 7.62, 6.30, 0.25-0.05, 0°-15°.</p> <p>P14DH-100-300A1,B-1</p>
<p>16-pin ceramic DIP (300mil)</p> <p>Top view: 20.32 MAX. Side view: 30.43, 5.08 MAX., 3.70, 0.89 MIN., 1.42 MIN., 0.51 MIN., 2.54, 1.27 MAX., 0.46-0.05, 0.25, 0.25. End view: 7.62, 6.75, 0.25-0.05, 0°-15°.</p> <p>P16DH-100-300A1-1</p>	<p>24-pin ceramic DIP (600mil)</p> <p>Top view: 33.02 MAX. Side view: 35.43, 5.08 MAX., 4.57 MAX., 2.64, 1.0 MIN., 0.92 MIN., 2.54, 2.54 MAX., 0.46-0.05, 0.25, 0.25. End view: 15.24, 14.93, 0.25-0.05, 0°-15°.</p> <p>P24D-100-600A-1</p>
<p>28-pin ceramic DIP (600mil)</p> <p>Top view: 38.10 MAX. Side view: 35.43, 5.08 MAX., 4.57 MAX., 2.64, 1.0 MIN., 0.92 MIN., 2.54, 2.54 MAX., 0.46-0.05, 0.25, 0.25. End view: 15.24, 14.93, 0.25-0.05, 0°-15°.</p> <p>P28D-100-600A1-1</p>	<p>42-pin ceramic DIP (600mil)</p> <p>Top view: 55.88 MAX. Side view: 35.43, 5.08 MAX., 4.57 MAX., 2.64, 1.0 MIN., 0.92 MIN., 2.54, 2.54 MAX., 0.46-0.05, 0.25, 0.25. End view: 15.24, 14.93, 0.25-0.05, 0°-15°.</p> <p>P42D-100-600A-1</p>
<p>48-pin ceramic DIP (600mil)</p> <p>Top view: 63.50 MAX. Side view: 35.43, 5.08 MAX., 4.57 MAX., 2.74, 1.0 MIN., 0.92 MIN., 2.54, 2.54 MAX., 0.46-0.05, 0.25, 0.25. End view: 15.24, 14.93, 0.25-0.05, 0°-15°.</p> <p>P48D-100-600A-1</p>	<p>64-pin ceramic DIP (750mil)</p> <p>Top view: 58.68 MAX. Side view: 35.43, 5.08 MAX., 5.08 MAX., 2.62, 1.0 MIN., 0.8 MIN., 1.778, 1.78 MAX., 0.46-0.05, 0.25, 0.25. End view: 19.05, 18.8, 0.25-0.05, 0°-15°.</p> <p>P64D-70-750A-1</p>

Plastic SOP (Small Out-line Package)

Units in mm

<p>8-pin plastic SOP (225mil)</p> <p>Top view: 8 pins, 5.37 MAX. width, pin 1 on left, pin 8 on right.</p> <p>Side view: 1.8 MAX. height, 0.1-0.1 lead length, 0.40±0.08 lead thickness, 0.78 MAX. body length, 1.27 lead pitch, 0.15±0.05 lead angle.</p> <p>Detail of lead end: 6.5-0.3 total length, 4.4 lead length, 1.1 lead height, 0.15±0.05 lead angle, 0.10 lead thickness.</p> <p>S8GM-50-225B-4</p>	<p>14-pin plastic SOP (225mil)</p> <p>Top view: 14 pins, 10.46 MAX. width, pin 1 on left, pin 14 on right.</p> <p>Side view: 1.8 MAX. height, 0.1-0.1 lead length, 0.40±0.08 lead thickness, 1.42 MAX. body length, 1.27 lead pitch, 0.15±0.05 lead angle.</p> <p>Detail of lead end: 6.5-0.3 total length, 4.4 lead length, 1.1 lead height, 0.15±0.05 lead angle, 0.10 lead thickness.</p> <p>S14GM-50-225B, C-4</p>
<p>14-pin plastic shrink SOP (225mil)</p> <p>Top view: 14 pins, 5.40 MAX. width, pin 1 on left, pin 14 on right.</p> <p>Side view: 1.8 MAX. height, 0.125±0.075 lead length, 0.65 lead thickness, 0.78 MAX. body length, 1.27 lead pitch, 0.30±0.05 lead angle.</p> <p>Detail of lead end: 6.2±0.3 total length, 4.4 lead length, 0.9 lead height, 0.15±0.05 lead angle, 0.10 lead thickness.</p> <p>P14GM-65-225B-2</p>	<p>16-pin plastic SOP (225mil)</p> <p>Top view: 16 pins, 10.46 MAX. width, pin 1 on left, pin 16 on right.</p> <p>Side view: 1.8 MAX. height, 0.1-0.1 lead length, 0.40±0.08 lead thickness, 0.78 MAX. body length, 1.27 lead pitch, 0.15±0.05 lead angle.</p> <p>Detail of lead end: 6.5-0.3 total length, 4.4 lead length, 1.1 lead height, 0.15±0.05 lead angle, 0.10 lead thickness.</p> <p>S16GM-50-225B, C-4</p>
<p>16-pin plastic SOP (300mil)</p> <p>Top view: 16 pins, 10.46 MAX. width, pin 1 on left, pin 16 on right.</p> <p>Side view: 1.8 MAX. height, 0.1-0.1 lead length, 0.40±0.08 lead thickness, 0.78 MAX. body length, 1.27 lead pitch, 0.15±0.05 lead angle.</p> <p>Detail of lead end: 7.7-0.3 total length, 5.6 lead length, 1.1 lead height, 0.15±0.05 lead angle, 0.10 lead thickness.</p> <p>P16GM-50-300B-4</p>	<p>16-pin plastic SOP (375mil)</p> <p>Top view: 16 pins, 11.73 MAX. width, pin 1 on left, pin 16 on right.</p> <p>Side view: 2.9 MAX. height, 0.15±0.05 lead length, 0.40±0.10 lead thickness, 1.42 MAX. body length, 1.27 lead pitch, 0.15±0.05 lead angle.</p> <p>Detail of lead end: 10.5±0.3 total length, 7.2 lead length, 1.6 lead height, 0.15±0.05 lead angle, 0.10 lead thickness.</p> <p>P16GM-50-375A-2</p>
<p>16-pin plastic SOP (575mil)</p> <p>Top view: 16 pins, 10.46 MAX. width, pin 1 on left, pin 16 on right.</p> <p>Side view: 2.9 MAX. height, 0.125±0.075 lead length, 0.40±0.08 lead thickness, 0.78 MAX. body length, 1.27 lead pitch, 0.15±0.05 lead angle.</p> <p>Detail of lead end: 10.3±0.3 total length, 7.2 lead length, 1.6 lead height, 0.15±0.05 lead angle, 0.15 lead thickness.</p> <p>P16GM-50-375B-3</p>	<p>20-pin plastic SOP (300mil)</p> <p>Top view: 20 pins, 13.00 MAX. width, pin 1 on left, pin 20 on right.</p> <p>Side view: 1.8 MAX. height, 0.1-0.1 lead length, 0.40±0.08 lead thickness, 0.78 MAX. body length, 1.27 lead pitch, 0.15±0.05 lead angle.</p> <p>Detail of lead end: 7.7-0.3 total length, 5.6 lead length, 1.1 lead height, 0.15±0.05 lead angle, 0.10 lead thickness.</p> <p>P20GM-50-300B, C-4</p>

Plastic SOP (Small Out-line Package)

Units in mm

<p>20-pin plastic SOP (375mil)</p> <p style="text-align: center;">P20GM-50-375B-4</p>	<p>24-pin plastic SOP (300mil)</p> <p style="text-align: center;">P24GM-50-300B-4</p>
<p>24-pin plastic SOP (375mil)</p> <p style="text-align: center;">P24GM-50-375B-3</p>	<p>24-pin plastic SOP (450mil)</p> <p style="text-align: center;">P24GM-50-450A-2</p>
<p>28-pin plastic SOP (375mil)</p> <p style="text-align: center;">P28GM-50-375B-3</p>	<p>28-pin plastic SOP (450mil)</p> <p style="text-align: center;">P28GM-50-450A1-2</p>
<p>28-pin plastic SOP (450mil)</p> <p style="text-align: center;">P28GM-50-450A2-2</p>	<p>36-pin plastic shrink SOP (300mil)</p> <p style="text-align: center;">P36GM-80-300B-3</p>

Plastic TSOP (Thin Small Out-line Package)

Units in mm

<p>32-pin plastic TSOP(I) (8 ∞ 20)</p> <p style="text-align: center;">S32GZ-50-KJH-1</p>	<p>32-pin plastic TSOP(II) (400mil)</p> <p style="text-align: center;">S32G5-50-7JD-2</p>
<p>40-pin plastic TSOP(I) (10 ∞ 20)</p> <p style="text-align: center;">S40GZ-50-LJH-1</p>	<p>44-pin plastic TSOP(II) (400mil)</p> <p style="text-align: center;">S44G5-80-7JF1-1</p>
<p>26-pin plastic TSOP(II) (300mil)</p> <p style="text-align: center;">S26G3-50-7JD1</p>	<p>50-pin plastic TSOP(II) (400mil)</p> <p style="text-align: center;">S50G5-80-7JF2</p>
<p>28-pin plastic TSOP(II) (400mil)</p> <p style="text-align: center;">S28G5-50-7JD-2</p>	<p>70-pin plastic TSOP(II) (400mil)</p> <p style="text-align: center;">S70G5-65-7JG</p>

Plastic QFP (Quad Flat Package)

Units in mm

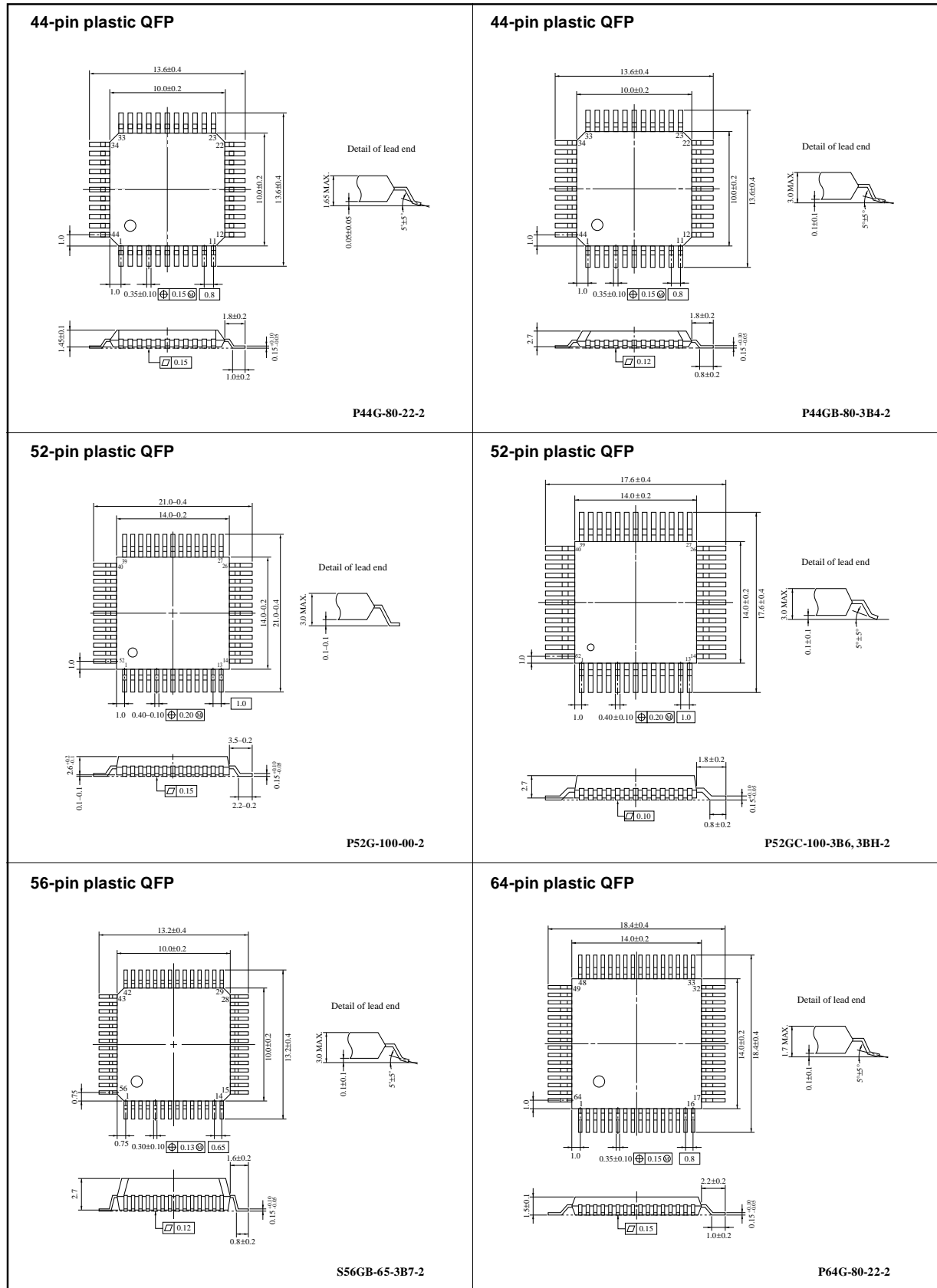

Plastic QFP (Quad Flat Package)

Units in mm

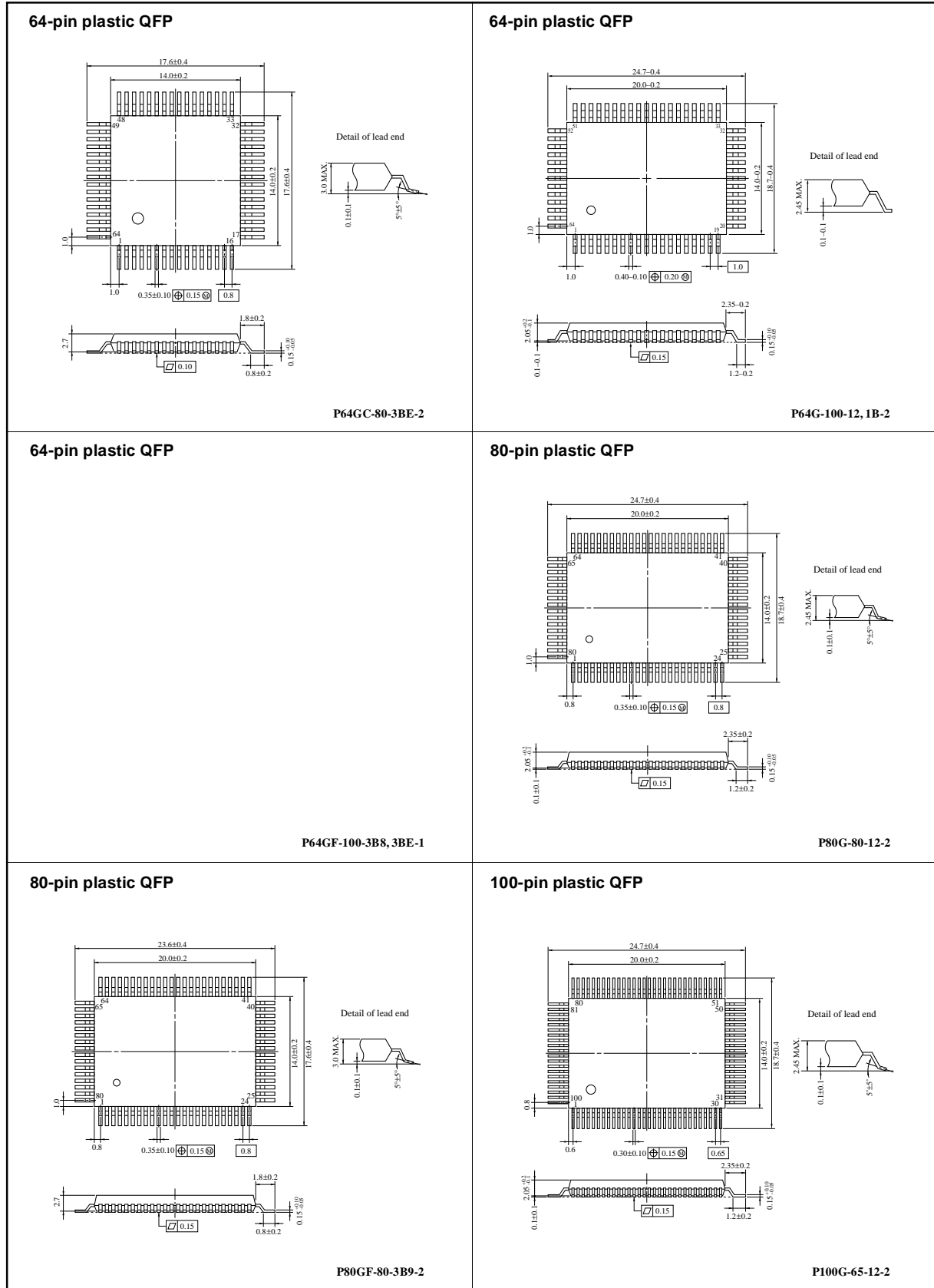

Plastic QFP (Quad Flat Package)

Units in mm

100-pin plastic QFP

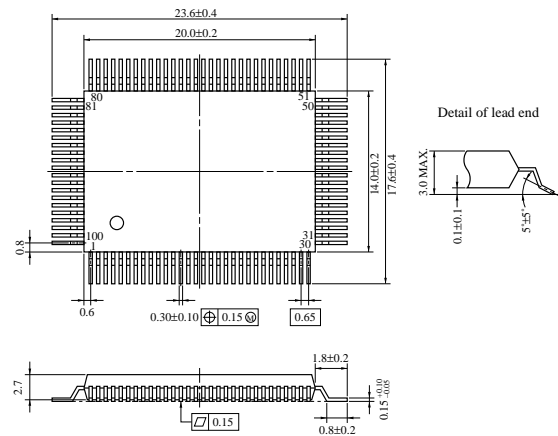

P100GF-65-3BA-2

120-pin plastic QFP

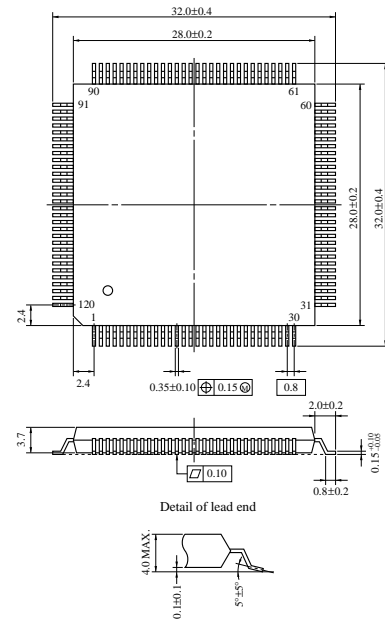

P120GD-80-5BB-3

136-pin plastic QFP

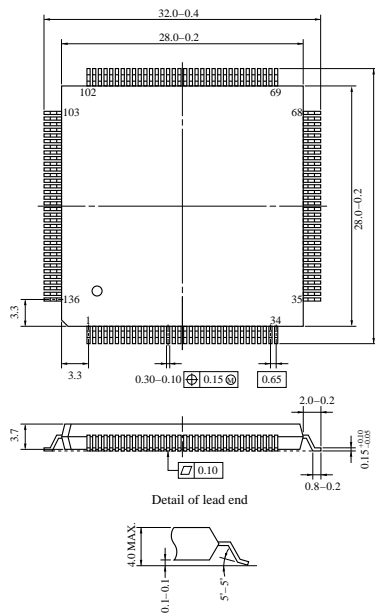

P136GD-65-5BC-3

160-pin plastic QFP

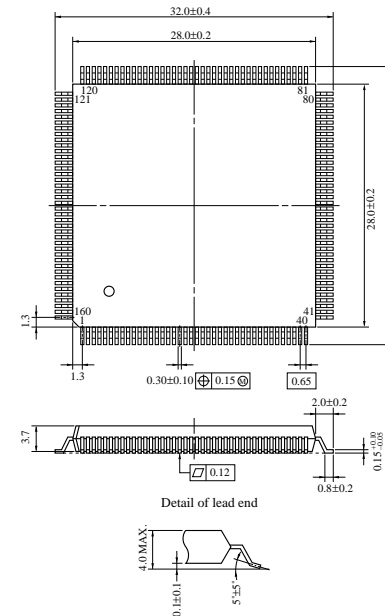

P160GD-65-5BD-2

QFJ (Quad Flat J-Lead)

Units in mm

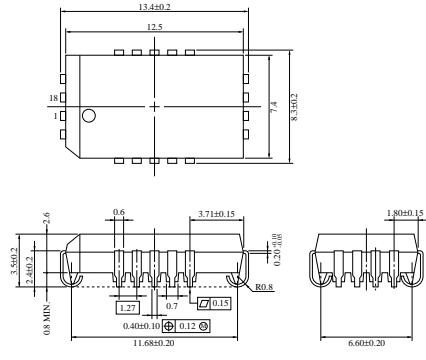
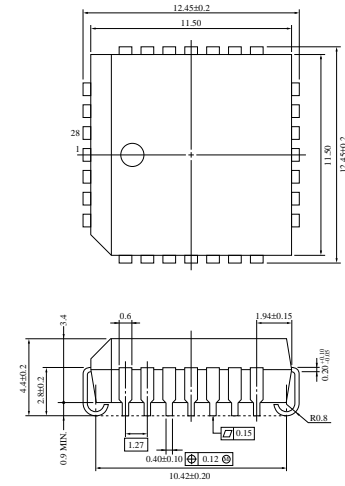
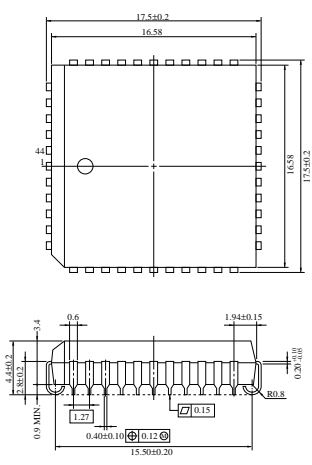
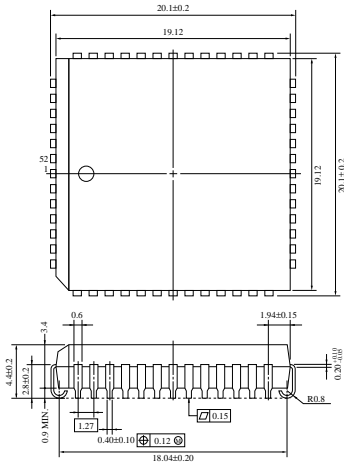
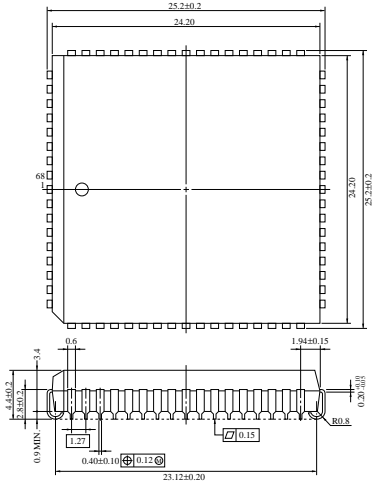
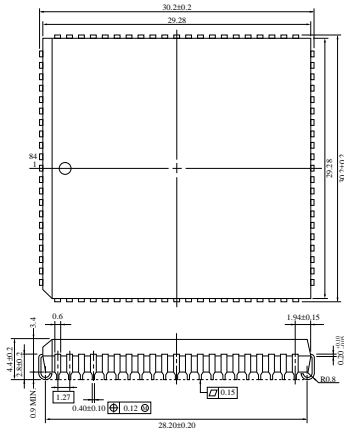
<p>18-pin QFJ</p>  <p>P18L-50A-2</p>	<p>28-pin QFJ</p>  <p>P28L-50A1-2</p>
<p>44-pin QFJ</p>  <p>P44L-50A1-2</p>	<p>52-pin QFJ</p>  <p>P52L-50A1-2</p>
<p>68-pin QFJ</p>  <p>P68L-50A1-2</p>	<p>84-pin QFJ</p>  <p>P84L-50A3-2</p>

Ceramic PGA (Pin Grid Array)

Units in mm

68-pin ceramic PGA

132-pin ceramic PGA

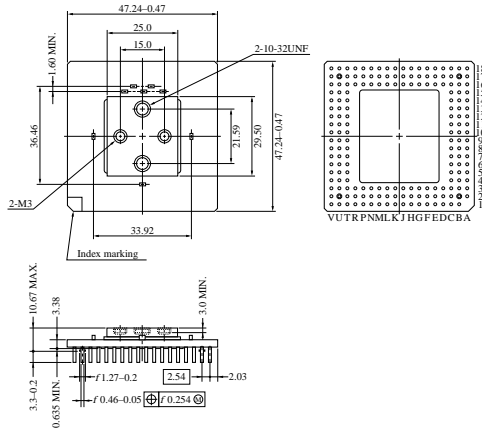

X179RP-100A

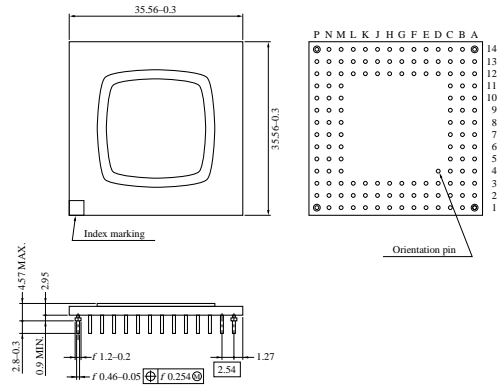

X132R-100A-1

447-pin ceramic PGA

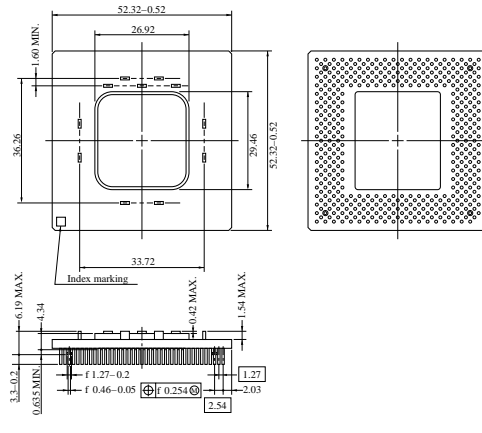

X447RG-50A-2

Plastic SIP (Single In-line Package)

Units in mm

<p>7-pin plastic slim SIP</p> <p style="text-align: right;">P7HA-254B</p>	<p>7-pin plastic power SIP</p> <p style="text-align: right;">P7HP-254B</p>
<p>8-pin plastic slim SIP</p> <p style="text-align: right;">P8HA-254B</p>	<p>8-pin plastic power SIP</p> <p style="text-align: right;">P8HP-254B</p>
<p>9-pin plastic slim SIP</p> <p style="text-align: right;">P9HA-254B</p>	<p>9-pin plastic power SIP</p> <p style="text-align: right;">P9HP-254B-1</p>
<p>10-pin plastic slim SIP</p> <p style="text-align: right;">P10HP-254B1</p>	<p>12-pin plastic power SIP</p> <p style="text-align: right;">P12HP-154B2</p>

**Plastic V-DIP
(Vertical Dual In-line Package)**

**Plastic ZIP
(Zigzag In-line Package)**

Units in mm

<p>5-pin plastic power V-DIP</p> <p style="text-align: right;">P5VP-340B3-1</p>	<p>16-pin plastic ZIP</p> <p style="text-align: right;">P16V-254A-1</p>
<p>11-pin plastic power V-DIP</p> <p style="text-align: right;">P11VP-340B</p>	<p>19-pin plastic ZIP</p> <p style="text-align: right;">P19V-254B-1</p>
<p>14-pin plastic power V-DIP</p> <p style="text-align: right;">P15VP-254B</p>	<p>20-pin plastic ZIP</p> <p style="text-align: right;">P20V-254A-1</p>
<p>14-pin plastic power V-DIP</p> <p style="text-align: right;">P14VP-340B</p>	<p>24-pin plastic ZIP</p> <p style="text-align: right;">P24V-254-400A-1</p>

Plastic Mold

Units in mm

<p>2-pin ultra super mini mold</p>	<p>3-pin super mini mold (SC-70)</p>
<p>2-pin super mini mold</p>	<p>3-pin mini mold (SC-59)</p>
<p>2-pin power mini mold</p>	<p>3-pin power mini mold (SC-62)</p>
<p>3-pin ultra super mini mold</p>	<p>MP-2</p>

Plastic Mold

Units in mm

MP-3Z (SC-64)	6-pin super mini mold
MP-25Z	6-pin mini mold
5-pin super mini mold	
5-pin mini mold	

Plastic Mold

Units in mm

<p>TO-92</p>	<p>SST</p>
<p>SP-8</p>	<p>MP-3 (SC-63)</p>
<p>MP-25 (TO-220)</p>	<p>MP-45F</p>
<p>MP-10</p>	<p>MP-88</p>

INDEX

Quick Reference Table by Type Number

Type number	Page	Type number	Page	Type number	Page	Type number	Page	Type number	Page
[Numerals]		2SA1424	135	2SA953	128,138	2SB768	131,137,142	2SC2516	132,141
03P2J	163	2SA1441	133,140	2SA954	128,138	2SB772	131,140	2SC2516A	132
03P2M	163	2SA1442	133,140	2SA985	132,143	2SB794	131,144	2SC2517	132,141
03P4J	163	2SA1443	133,140	2SA985A	132,143	2SB795	131,144	2SC2518	132,141
03P4M	163	2SA1444	133,140	2SA987	128,138	2SB798	136,138	2SC2570A	177
03P4MF	163	2SA1458	129,139	2SA988	128,138	2SB799	136,138	2SC2571	141
03P4MG	163	2SA1459	129,139	2SA990	128,138	2SB800	136,138	2SC2654	132,143
03P5J	163	2SA1460	130,139,141	2SA991	128,138	2SB804	136,138	2SC2682	131
03P5MG	163	2SA1461	135,139	2SA992	128,138	2SB805	136,138	2SC2688	131,143
03P6MG	163	2SA1462	135,139	2SB1038	132,142	2SB806	136,138	2SC2690	131,143
2P4M	163	2SA1463	136,139	2SB1068	128,138	2SB810	129,138	2SC2690A	131,143
2P5M	163	2SA1464	135,139	2SB1087	144	2SB811	129,138	2SC2718	128
2P6M	163	2SA1467	135	2SB1089	142	2SB849A	134,142	2SC2719	128
2S2M	163	2SA1486	131,141	2SB1093	130,144	2SB897	134,144	2SC2720	139
2S4M	163	2SA1544	128	2SB1094	133,142	2SB962	131,140	2SC2721	130
2SA1005	128,138	2SA1546	131,143	2SB1096	133,142	2SB962-Z	137	2SC2749	134,141
2SA1006	132,143	2SA1608	137,139	2SB1097	133,142	2SB963	131,144	2SC2750	134,141
2SA1006A	132,143	2SA1609	137,138	2SB1098	133,144	2SB963-Z	137	2SC2751	134
2SA1006B	132,143	2SA1610	137,139	2SB1099	133,144	2SB965	134,142	2SC2752	131,141
2SA1008	132,141	2SA1611	137,138	2SB1100	133,144	2SB966	134,142	2SC2757	135
2SA1009	132,141	2SA1612	137,138	2SB1111	131,144	2SB974	132,144	2SC2758	135
2SA1009A	132,141	2SA1613	137,138	2SB1114	136,138	2SB975	132,144	2SC2759	135
2SA1010	132,141	2SA1615	131,140	2SB1115	136,138	2SB984	130	2SC2762	168
2SA1069	132,141	2SA1615-Z	137	2SB1115A	136,138	2SC1009A	135,138	2SC2780	136,139
2SA1069A	132	2SA1625	128	2SB1116	128,138	2SC1044	168	2SC2784	129,138
2SA1129	132,143	2SA1626	130	2SB1116A	128,138	2SC1275	168	2SC2785	129,138
2SA1138	138	2SA1627	130	2SB1117	130,140	2SC1424	168	2SC2786	129,138
2SA1141	134	2SA1644	132,140	2SB1149	131,144	2SC1426	168	2SC2787	129,138
2SA1142	131	2SA1645	132,140	2SB1150	131,144	2SC1449	131,143	2SC2802	131,137,143
2SA1151	128	2SA1646	132,140	2SB1151	131,140	2SC1505	132,143	2SC2850-KA	168
2SA1152	128	2SA1647	131,140	2SB1217	131,140	2SC1506	132,143	2SC2850-MA	168
2SA1153	139	2SA1648	131,140	2SB1261	131,140	2SC1507	132,143	2SC2885	131,141
2SA1154	130	2SA1649	131,140	2SB1261-Z	137	2SC1621	135	2SC2901	128,139
2SA1156	131,141	2SA1650	133,140	2SB1300	128	2SC1622A	135,138	2SC2908	134
2SA1173	136,138	2SA1651	133,140	2SB1301	136	2SC1623	135,138	2SC2946	131,141
2SA1174	129,138	2SA1652	133,140	2SB1315	142	2SC1653	135,139	2SC2946(1)	131,137,141
2SA1175	129,138	2SA1714	131,144	2SB1318	130	2SC1654	135,139	2SC2954	136
2SA1206	128,139	2SA1715	144	2SB1430	133,144	2SC1674	128,138	2SC2958	130
2SA1220	131,143	2SA1716	132,144	2SB1431	133,144	2SC1675	128,138	2SC2959	130
2SA1220A	131,143	2SA1717	132,144	2SB1432	133,144	2SC1840	128,138	2SC2987	134,143
2SA1221	130	2SA1718	133,144	2SB1475	137	2SC1841	128,138	2SC2987A	134,143
2SA1222	130	2SA1719	133,144	2SB1571	136	2SC1842	128,138	2SC3012	134,143
2SA1226	135,138	2SA1720	133,144	2SB1572	136	2SC1843	128,138	2SC3115	135,138
2SA1227	134,143	2SA1741	133,140	2SB1578	136,140	2SC1844	128,138	2SC3157	132
2SA1227A	134,143	2SA1742	133,140	2SB1581	136,140	2SC1845	128,138	2SC3158	132,141
2SA1232	134,143	2SA1743	133,140	2SB536	132,142	2SC1940	130,139	2SC3159	132,141
2SA1247	135,138	2SA1744	133,140	2SB537	132,142	2SC1941	130,139	2SC3209	130,139,143
2SA1261	132	2SA1833	133,144	2SB546A	132,142	2SC2001	128,138	2SC3217-M	168
2SA1330	135,138	2SA1836	137	2SB547A	132,142	2SC2002	128,138	2SC3218-M	168
2SA1376	128,138	2SA1840	134,144	2SB548	131,142	2SC2003	128,138	2SC3282A	168
2SA1376A	128	2SA1841	134,144	2SB549	131,142	2SC2148	168	2SC3283A	168
2SA1383	132	2SA1842	134,144	2SB564	130,138	2SC2149	168	2SC3355	177
2SA1385	131,140	2SA1843	134,140	2SB601	132,144	2SC2150	168	2SC3356	135,177
2SA1385-Z	137	2SA1844	134,140	2SB605	130,138	2SC2223	135,138	2SC3357	136
2SA1394	133,141	2SA1845	134,140	2SB624	135,138	2SC2275	132,143	2SC3360	135,138
2SA1395	133,141	2SA1846	134,140	2SB703	132,142	2SC2275A	132,143	2SC3431	132,141
2SA1396	133,141	2SA1847	134,140	2SB703A	132,142	2SC2331	132,141	2SC3432	132,141
2SA1400	131,141	2SA1871	136	2SB707	132,142	2SC2333	132,141	2SC3434	134,141
2SA1400-Z	137	2SA1897	130,140	2SB708	132,142	2SC2334	132,141	2SC3435	134,141
2SA1409	128,138	2SA675	128	2SB731	131,142	2SC2335	132,141	2SC3478	128,138
2SA1410	129,138	2SA733	128,138	2SB733	130,138	2SC2336	132,143	2SC3478A	128
2SA1411	135,138	2SA811A	135,138	2SB734	130,138	2SC2336A	132,143	2SC3514	132
2SA1412	131	2SA812	135,138	2SB736	135,138	2SC2336B	132,143	2SC3518	131,140
2SA1412-Z	137	2SA915	130,138	2SB736A	135,138	2SC2351	135,177	2SC3518-Z	137
2SA1413	131,141	2SA916	130,138	2SB744	131,142	2SC2371	131,143	2SC3531	132,141
2SA1413-Z	137	2SA952	128,138	2SB744A	131,142	2SC2373	132,141	2SC3532	132,141

Quick Reference Table by Type Number

Type number	Page	Type number	Page	Type number	Page	Type number	Page	Type number	Page
2SC3533	134,141	2SC4095	135	2SC5005	177	2SD1615	136,139	2SD987	132,144
2SC3534	134,141	2SC4173	137,139	2SC5006	177	2SD1615A	136,139	2SD992	131,142
2SC3535	134,141	2SC4175	137	2SC5008	177	2SD1616	128,139	2SD992-Z	137
2SC3536	134,141	2SC4176	137,139	2SC5011	177	2SD1616A	128,139	2SD999	136,139
2SC3537	168	2SC4177	137,138	2SC5013	177	2SD1629	132	2SJ128	153
2SC3538	168	2SC4178	137,138	2SC5185	102	2SD1630	131,144	2SJ132	153
2SC3539	168	2SC4179	137,138	2SC945	128,138	2SD1691	131,140	2SJ133	153
2SC3541	168	2SC4180	137	2SC945 (L)	128,138	2SD1692	131,144	2SJ134	153
2SC3542	168	2SC4181	137,138	2SD1000	136,139	2SD1693	131,144	2SJ135	153
2SC3545	135,176,177	2SC4182	176	2SD1001	136,138	2SD1694	131,140	2SJ136	153
2SC3554	136,139	2SC4183	176	2SD1005	136,139	2SD1695	131,144	2SJ137	153
2SC3566	133,141	2SC4184	176,177	2SD1006	136,139	2SD1697	130,139,144	2SJ138	153
2SC3567	133,141	2SC4185	176,177	2SD1007	136,139	2SD1698	128,139	2SJ139	153
2SC3568	133,141	2SC4186	176	2SD1017	134,142	2SD1699	136,139	2SJ140	153
2SC3569	133,141	2SC4226	177	2SD1018	134,142	2SD1700	130,139,144	2SJ141	153
2SC3570	133,141	2SC4228	177	2SD1020	129,138	2SD1701	128,139	2SJ142	153
2SC3571	133,141	2SC4328	132,140	2SD1021	129	2SD1702	136,139	2SJ143	153
2SC3572	133,141	2SC4329	132,140	2SD1033	131,137,142	2SD1779	130	2SJ151	153
2SC3583	135	2SC4330	132,140	2SD1070	134,142	2SD1780	130	2SJ152	153
2SC3585	135	2SC4331	131,140	2SD1110A	134,142	2SD1818	131,140	2SJ153	153
2SC3587	168	2SC4332	131,140	2SD1162	132,144	2SD1843	130,144	2SJ154	153
2SC3588	131,141	2SC4333	131,140	2SD1164	131,144	2SD1899	131,140	2SJ165	147
2SC3588-Z	137	2SC4334	133,140	2SD1164-Z	137	2SD1899-Z	137	2SJ166	147
2SC3603	168	2SC4335	133,140	2SD1210	134,144	2SD1928	133,144	2SJ178	147
2SC3604	168	2SC4336	133,140	2SD1286	131,144	2SD1939	128	2SJ179	136,147
2SC3615	128,139	2SC4337	131,144	2SD1286-Z	137	2SD1950	136,139	2SJ180	147
2SC3616	128,139	2SC4338	131,144	2SD1288	134,142	2SD1977	142	2SJ184	147
2SC3617	136,139	2SC4339	131,144	2SD1289	134,142	2SD2161	133,144	2SJ185	147
2SC3618	136,139	2SC4340	131,144	2SD1296	134,144	2SD2162	133,144	2SJ196	147
2SC3622	128,138	2SC4341	131,144	2SD1297	134,144	2SD2163	133,144	2SJ197	147
2SC3622A	128,138	2SC4342	131,144	2SD1298	134,144	2SD2164	133,140	2SJ198	147
2SC3623	129,138	2SC4343	131,140	2SD1308	132,144	2SD2165	133,140	2SJ199	147
2SC3623A	129,138	2SC4344	131,140	2SD1309	132,144	2SD2228	137	2SJ202	147
2SC3624	135,138	2SC4345	131,144	2SD1310	132,142	2SD2383	135	2SJ203	147
2SC3624A	135,138	2SC4346	131,141	2SD1311	132,142	2SD2402	136	2SJ204	147
2SC3631	131,141	2SC4347	132,144	2SD1312	130	2SD2403	136	2SJ205	147
2SC3631-Z	137	2SC4348	132,144	2SD1392	132,144	2SD2425	136,140	2SJ206	147
2SC3632	131,141	2SC4349	132,144	2SD1448	131,142	2SD2463	130,144	2SJ207	147
2SC3632-Z	137	2SC4350	132,144	2SD1448-Z	137	2SD288	132,142	2SJ208	147
2SC3660	168	2SC4351	133,144	2SD1481	132	2SD289	132,142	2SJ209	147
2SC3660A	168	2SC4352	133,144	2SD1491	131,144	2SD381	132,142	2SJ210	147
2SC3663	135	2SC4353	133,144	2SD1513	128,139	2SD382	132,142	2SJ211	147
2SC3691	133,140	2SC4496	132	2SD1557	131,142	2SD401A	132,142	2SJ212	147
2SC3692	133,140	2SC4549	133,140	2SD1564	144	2SD402A	132,142	2SJ218	147
2SC3693	133,140	2SC4550	133,140	2SD1565	144	2SD414	131,142	2SJ243	147
2SC3694	133,140	2SC4551	133,140	2SD1567	142	2SD415	131,142	2SJ302	153
2SC3731	129,139	2SC4552	133,140	2SD1568	142	2SD471	130,139	2SJ303	153
2SC3732	129,139	2SC4553	133,140	2SD1579	130,144	2SD560	132,144	2SJ324	153
2SC3733	130,139,141	2SC4554	133,140	2SD1581	130,139,140	2SD568	132,142	2SJ325	153
2SC3734	135,139	2SC4568	135,177	2SD1582	130,140	2SD569	132,142	2SJ326	153
2SC3735	135,139	2SC4569	135,177	2SD1583	131,140	2SD571	130,139	2SJ327	153
2SC3736	136,139	2SC4570	177	2SD1583-Z	137	2SD596	135,138	2SJ328	153
2SC3739	135,139	2SC4571	177	2SD1584	131,140	2SD741	131,140	2SJ329	153
2SC3742	135	2SC4783	137	2SD1584-Z	137	2SD743	132,142	2SJ330	153
2SC3817	168	2SC4810	134,144	2SD1585	133,142	2SD743A	132,142	2SJ331	153
2SC3818	168	2SC4811	134,144	2SD1586	133,142	2SD773	130,139	2SJ353	147
2SC3819	168	2SC4812	134,144	2SD1587	133,142	2SD774	130,139	2SJ411	147
2SC3840	131,141	2SC4813	134,140	2SD1588	133,142	2SD780	135,138	2SJ44	147
2SC3841	176	2SC4814	134,140	2SD1589	133,144	2SD780A	135,138	2SJ45	147
2SC4000	130,143	2SC4815	134,140	2SD1590	133,144	2SD794	131,142	2SJ460	147
2SC4001	131,143	2SC4816	134,140	2SD1591	133,144	2SD794A	131,142	2SJ461	147
2SC4062	133,140	2SC4817	134,140	2SD1592	133,144	2SD795	132,142	2SJ462	147
2SC4063	133,140	2SC4818	134,140	2SD1593	133,140	2SD809(1)	131,142	2SJ463	147
2SC4092	135,177	2SC4819	134,140	2SD1594	133,140	2SD882	131,140	2SK1000	145
2SC4093	135,177	2SC4942	136	2SD1595	133,144	2SD985	131,144	2SK104	145
2SC4094	135	2SC5004	177	2SD1614	136,139	2SD986	131,144	2SK105	145

Quick Reference Table by Type Number

Type number	Page	Type number	Page	Type number	Page	Type number	Page	Type number	Page
2SK1059	149	2SK163	145	2SK2396	168	2SK774	148	3SK230	176
2SK1060	149	2SK1664	150	2SK2409	151	2SK784	148	3SK231	176
2SK1109	145	2SK1748	150	2SK2410	151	2SK785	148	3SK242	176
2SK1122	149	2SK1749	150	2SK2411	152	2SK786	148	3SK243	176
2SK1123	149	2SK1750	150	2SK2412	152	2SK787	148	3SK244	176
2SK1132	145	2SK1751	150	2SK2413	152	2SK797	148	3SK245	176
2SK1133	145	2SK1752	150	2SK2414	152	2SK798	148	3SK246	176
2SK1149	149	2SK1753	150	2SK2415	152	2SK799	148	3SK252	176
2SK1150	149	2SK1756	150	2SK2461	152	2SK800	148	3SK253	176
2SK1198	149	2SK1757	150	2SK2462	152	2SK801	148	3SK254	176
2SK1271	150	2SK1758	151	2SK2476	152	2SK802	148	3SK255	176
2SK1272	145	2SK1760	151	2SK2477	152	2SK810	148	5P4J	163
2SK1273	145	2SK1784	151	2SK2478	152	2SK811	148	5P4J-Z	163
2SK1274	146	2SK1785	151	2SK2479	152	2SK812	148	5P4M	163
2SK1281	150	2SK1793	151	2SK2480	152	2SK813	148	5P4SM	163
2SK1282	150	2SK1794	151	2SK2481	152	2SK814	148	5P5M	163
2SK1283	150	2SK1795	151	2SK2482	152	2SK815	149	5P6J	163
2SK1284	150	2SK1796	151	2SK2483	152	2SK817	149	5P6J-Z	163
2SK1285	150	2SK1824	146	2SK2484	152	2SK819	149	5P6M	163
2SK1286	150	2SK1850	151	2SK2485	152	2SK820	149	5P6SM	163
2SK1287	150	2SK1851	151	2SK2486	152	2SK821	149	8P2M	163
2SK1288	150	2SK1852	151	2SK2487	152	2SK822	149	8P2SM	163
2SK1289	150	2SK1853	151	2SK2488	152	2SK823	149	8P4J	163
2SK1290	150	2SK193	145	2SK2498	152	2SK824	149	8P4J-Z	163
2SK1291	150	2SK195	145	2SK2499	152	2SK825	149	8P4M	163
2SK1292	150	2SK1953	151	2SK2510	152	2SK826	149	8P4SM	163
2SK1293	150	2SK1954	151	2SK2511	152	2SK827	149		
2SK1294	150	2SK1958	146	2SK2512	152	2SK828	149	[A]	
2SK1295	150	2SK1959	146	2SK2513	152	2SK829	149	AA1[]	128,154
2SK1398	146	2SK1960	146	2SK2514	152	2SK830	149	AB1[]	128,155
2SK1399	146	2SK1987	151	2SK2515	152	2SK831	149	AC01DGM	163
2SK1482	146	2SK1988	151	2SK2541	146	2SK832	149	AC01DJM	163
2SK1483	146	2SK1989	151	2SK2597	168	2SK833	149	AC03DGM	163
2SK1484	146	2SK1990	151	2SK459	148	2SK854	149	AC03DJM	163
2SK1485	146	2SK1991	151	2SK505	145	2SK855	149	AC03DJM-Z	163
2SK1491	150	2SK1992	151	2SK507	145	2SK871	149	AC03DSM	163
2SK1492	150	2SK1993	151	2SK514	145	2SK872	149	AC03FGM	163
2SK1493	150	2SK1994	151	2SK518	145	2SK873	149	AC03FJM	163
2SK1494	150	2SK1995	151	2SK519	145	2SK874	149	AC03FJM-Z	163
2SK1495	150	2SK2040	151	2SK523	145	2SK875	149	AC03FSM	163
2SK1496	150	2SK2053	146	2SK533	145	2SK876	149	AC05DGM	163
2SK1497	150	2SK2054	146	2SK591	148	2SK926	149	AC05DJM	163
2SK1498	150	2SK2055	146	2SK611	148	2SK928	149	AC05DJM-Z	163
2SK1499	150	2SK2070	146	2SK612	148	2SK929	149	AC05DSM	163
2SK1500	150	2SK2090	146	2SK654	148	2SK946	149	AC05EGM	163
2SK1501	150	2SK2109	146	2SK659	148	2SK991	149	AC05ESM	163
2SK1502	150	2SK2110	146	2SK660	145	2SK992	149	AC05FGM	163
2SK1580	146	2SK2111	146	2SK679A	145	2SK993	149	AC05FJM	163
2SK1581	146	2SK2112	146	2SK680A	145	2SK994	149	AC05FJM-Z	163
2SK1582	146	2SK2131	151	2SK681A	145	2SK997	145	AC05FSM	163
2SK1583	146	2SK2132	151	2SK699	148	2SK998	145	AC08DGM	163
2SK1584	146	2SK2133	151	2SK700	148	2V5P4M	163	AC08DSM	163
2SK1585	146	2SK2134	151	2SK701	148	3P4J	163	AC08EGM	163
2SK1586	146	2SK2135	151	2SK702	148	3P4J-Z	163	AC08ESM	163
2SK1587	146	2SK2136	151	2SK703	148	3P4MH	163	AC08FGM	163
2SK1588	146	2SK2137	151	2SK704	148	3P5MH	163	AC08FSM	163
2SK1589	146	2SK2138	151	2SK705	148	3P6MH	163	AC0V8DGM	163
2SK1590	146	2SK2139	151	2SK707	148	3S4M	163	AC1[]	128,155
2SK1591	146	2SK2140	151	2SK719	148	3SK131	176	AC10DGM	163
2SK1592	146	2SK2141	151	2SK720A	148	3SK134B	176	AC10DSM	163
2SK1593	146	2SK2157	146	2SK735	148	3SK135A	176	AC10EGM	163
2SK1594	150	2SK2158	146	2SK736	148	3SK177	176	AC10ESM	163
2SK1595	150	2SK2159	146	2SK737	148	3SK206	176	AC10FGM	163
2SK1596	150	2SK2234	151	2SK738	148	3SK222	176	AC10FSM	163
2SK160	135	2SK2275	151	2SK739	148	3SK223	176	AC12DGM	163
2SK162	145	2SK2341	151	2SK773	148	3SK224	176	AC12DSM	163

Quick Reference Table by Type Number

Type number	Page	Type number	Page	Type number	Page	Type number	Page	Type number	Page
AC12EGM	163	MC-422000FB72	73	μPA1523	160	μPB1505	174	μPC1830	113
AC12ESM	163	MC-422000LAB72	73	μPA1523B	160	μPB581	174	μPC1851	113
AC12FGM	163	MC-422000LFB72	73	μPA1524	160	μPB582	174	μPC1852A	113
AC12FSM	163	MC-424000A32	72	μPA1526	160	μPB584	174	μPC1853	113
AC16DGM	163	MC-424000A36	72	μPA1527	160	μPB585	174	μPC1860	113
AC16DSM	163	MC-424000AB72	73	μPA1550	160	μPB586	174	μPC1862	113
AC16EGM	163	MC-424000AC72	73	μPA1552	160	μPB587	174	μPC1872A	113
AC16FGM	163	MC-424000F32	72	μPA1552A	160	μPB588	174	μPC1874	113
AC16FSM	163	MC-424000FB72	73	μPA1552B	160	μPB63020	90	μPC1875	113
AC2[]	128,156	MC-424000FC72	73	μPA1556	160	μPB63040	90	μPC1881	114
AD1[]	128,156	MC-424000LAB72	73	μPA1556A	160	μPB63060	90	μPC1883	114
AD2[]	128,156	MC-424000LAC72	73	μPA1570	160	μPB63080	90	μPC1891A	113
AN1[]	128,154	MC-424000LFB72	73	μPA1572	160	μPB63100	90	μPC1892	113
AP1[]	128,155	MC-424000LFC72	73	μPA1576	160	μPC1060	124	μPC1900	125
AQ1[]	128,155	MC-428000A32	72	μPA1600	160	μPC1074A	124	μPC1905	125
AQ2[]	128,156	MC-428000A36	72	μPA1601	160	μPC1093	124	μPC1906	125
AR1[]	128,156	MC-428000F32	72	μPA1602	160	μPC1094	125	μPC1943	124
		MC-42S1000LAD32S	72	μPA1603	160	μPC1099	125	μPC1944	124
[B]		MC-42S2000LAB32S	72	μPA1604	160	μPC1100	125	μPC2002	110
BA1[]	129,154	MC-42S2000LAD32S	72	μPA1640	160	μPC1150	125	μPC2102	105
BA2[]	129,157	MC-42S4000LAB32S	72	μPA1700	152	μPC1188	110	μPC2132	105
BA3[]	129,157	MC-42S4000LAC32S	72	μPA1701	152	μPC1225	111	μPC2133	105
BB1[]	129,155	MC-452AA72	74	μPA2001	159	μPC1228	110	μPC2138	105
BN1[]	129,154	MC-452AA80	74	μPA2002	159	μPC1237	111	μPC2251	124
BN2[]	129,157	MC-452BA72	74	μPA2003	159	μPC1238	110	μPC2252	124
BN3[]	129,157	MC-454BA72	74	μPA2004	159	μPC1251	122	μPC2253	124
BP1[]	129,155	MC-454BA80	74	μPA2981	159	μPC1270	111	μPC2254	124
		MC-454BC72	74	μPA2982	159	μPC1297	111	μPC2255	124
[C]		MC-454BC80	74	μPA2987	159	μPC1298	111	μPC2256	124
CE1[]	130,156	MC-5720	110	μPA500	158	μPC1308	110	μPC2260	124
CE2[]	130,156	MC-5720A	110	μPA501	158	μPC1310	110	μPC2270A	124
		MC-5950	166	μPA502	158	μPC1313	110	μPC2372	117
[F]		MC-5951	104,166	μPA503	158	μPC1316	110	μPC2394	117
FA1[]	135	MC-5952	104,166	μPA504	158	μPC1318A	110	μPC2400A	123
FA2[]	135	MC-5973	104,166	μPA505	158	μPC1330	111	μPC24A00	123
FB1[]	135	MC-5974	104,166	μPA53	159	μPC1342	111	μPC24M00A	123
FN1[]	135	MC-7620	166	μPA56	159	μPC1394	125	μPC2500A	110
FN2[]	135	MC-7621	166	μPA57	159	μPC141	124	μPC2502	110
FP1[]	135	μPA101	174	μPA570	158	μPC1458	122	μPC2505	110
		μPA102	174	μPA571	158	μPC151	122	μPC2506	110
[G]		μPA103	174	μPA572	158	μPC1555	125	μPC251	122
GA1[]	137	μPA104	174	μPA573	158	μPC157	122	μPC2533	110
GN1[]	137	μPA1424	160	μPA574	158	μPC159	122	μPC2535	110
		μPA1426	160	μPA600	158	μPC1652	170	μPC254	122
[H]		μPA1427	160	μPA601	158	μPC1653	170	μPC2560	111
HC1[]	136	μPA1428	160	μPA602	158	μPC1654	170	μPC2572	111
HC2[]	136	μPA1428A	160	μPA603	158	μPC1655	170	μPC258	122
HD1[]	136	μPA1434	160	μPA604	158	μPC1656	170	μPC2581	111
HD2[]	136	μPA1436	160	μPA605	158	μPC1658	170	μPC259	122
HQ1[]	136	μPA1436A	160	μPA606	158	μPC1659	170	μPC2590	99
HQ2[]	136	μPA1437	160	μPA607	158	μPC1663	170	μPC2600	123
HR1[]	136	μPA1438	160	μPA608	158	μPC1668	170	μPC2708	170
		μPA1452	160	μPA609	158	μPC1669	170	μPC2709	170
[M]		μPA1453	160	μPA6118	159	μPC1670	170	μPC271	123
MC-421000A32	72	μPA1454	160	μPA67	159	μPC1673	174	μPC2710	170
MC-421000A36	72	μPA1456	160	μPA670	158	μPC1675	170	μPC2711	170
MC-421000AA64	73	μPA1457	160	μPA671	158	μPC1676	170	μPC2712	170
MC-421000AD72	73	μPA1458	160	μPA672	158	μPC1677	170	μPC2713	170
MC-421000F32	72	μPA1476	160	μPA673	158	μPC1678	170	μPC2714	170
MC-421000FA64	73	μPA1478	160	μPA674	158	μPC1685	174	μPC2715	170
MC-422000A32	72	μPA1500	160	μPA79	159	μPC1686	174	μPC272	123
MC-422000A36	72	μPA1500B	160	μPA80	159	μPC1687	174	μPC2721	174
MC-422000AA64	73	μPA1501	160	μPA81	159	μPC1688	170	μPC2722	174
MC-422000AB72	73	μPA1520	160	μPB1502	174	μPC1692	174	μPC2723	170
MC-422000F32	72	μPA1520B	160	μPB1502(1)	102,174	μPC1694	174	μPC2726	170
MC-422000FA64	73	μPA1522	160	μPB1504	104,174	μPC177	123	μPC2731	174

Quick Reference Table by Type Number

Type number	Page	Type number	Page	Type number	Page	Type number	Page	Type number	Page
μPC2734	174	μPC5034	94	μPD16304	106	μPD17006A	19	μPD17P149	21
μPC2743	174	μPC5102	94	μPD16305	108	μPD17010	19	μPD17P202A	22
μPC2744	174	μPC5200	94	μPD16306	106,108	μPD17012	19	μPD17P203A	22
μPC2745	170	μPC5201	94	μPD16306A	106,108	μPD17015	19	μPD17P204	22
μPC2746	170	μPC5202	94	μPD16307	108	μPD17016	19	μPD17P207	22
μPC2747	104,170	μPC5203	94	μPD16309	108	μPD17017	19	μPD17P218	22
μPC2748	104,170	μPC5204	94	μPD16310	106	μPD17052	20	μPD17P709	19
μPC2749	102,104,170	μPC610	119	μPD16311	106	μPD17053	20	μPD23C1000B	78
μPC2753	174	μPC617	125	μPD16312	106	μPD17062	20	μPD23C1000EB	78
μPC2757	102,104,174	μPC624	119	μPD16313	106	μPD17068	20	μPD23C1001EA	78
μPC2758	104,174	μPC648	119	μPD16320A	109	μPD17071	19	μPD23C1010B	78
μPC2762	104,170	μPC649	125	μPD16322	109	μPD17072	19	μPD23C16000LW	78
μPC2763	102,104,170	μPC650	118	μPD16325	106,108	μPD17073	19	μPD23C16000W	78
μPC277	123	μPC659A	118	μPD16326	106	μPD1708A	23	μPD23C16040A	78
μPC2771	104,170	μPC660	118	μPD16327	108	μPD1709A	23	μPD23C2001E	78
μPC2800A	117	μPC661	118	μPD16404	108	μPD17103	21	μPD23C32000	78
μPC2801A	117	μPC662	119	μPD16405	108	μPD17103L	21	μPD23C32140	78
μPC2803	117	μPC664	119	μPD16406	108	μPD17104	21	μPD23C4000S	78
μPC2900	123	μPC665	119	μPD16407	108	μPD17104L	21	μPD23C4001EJ	78
μPC29L00	123	μPC666	119	μPD16408	108	μPD17107	21	μPD23C4040	78
μPC29M00	123	μPC667	119	μPD16409A	108	μPD17107L	21	μPD23C8000LW	78
μPC301A	122	μPC668	118	μPD16429A	108	μPD17108	21	μPD23C8000W	78
μPC305	124	μPC7002	101	μPD16430A	107	μPD17108L	21	μPD23C8001EJ	78
μPC311	123	μPC7063	100	μPD16431A	107	μPD17120	21	μPD27C010A	79
μPC317	124	μPC7071	100	μPD16432B	107	μPD17121	21	μPD27C020	79
μPC318	122	μPC7151	100	μPD16434	107	μPD17132	21	μPD27C040	79
μPC319	123	μPC7161	100	μPD16435	107	μPD17133	21	μPD27C210A	79
μPC324	122	μPC741	122	μPD16435A	107	μPD17134A	21	μPD27C240	79
μPC337	124	μPC7800A	123	μPD16437	104,107	μPD17135A	21	μPD27C4000	79
μPC339	123	μPC78L00	123	μPD16437A	107	μPD17136A	21	μPD27C4001	79
μPC3403	122	μPC78M00A	123	μPD16443B	108	μPD17137A	21	μPD27C8000	79
μPC354	122	μPC78N00	123	μPD16444A	108	μPD1713A	23	μPD27C8001	79
μPC358	122	μPC7900A	123	μPD16445	108	μPD17145	21	μPD28C256	80
μPC393	123	μPC79L00	123	μPD16446	108	μPD17147	21	μPD28C64A	80
μPC398	125	μPC79M00	123	μPD16447	108	μPD17149	21	μPD28F001	80
μPC4061	122	μPC79N00	123	μPD16448	108	μPD1715	23	μPD30100	60
μPC4062	122	μPC8000	104	μPD16454A	104,107	μPD1716	23	μPD30200	60
μPC4064	122	μPC8001	104	μPD16501	117	μPD17201A	22	μPD30311	61
μPC4071	122	μPC8002	102	μPD16502	117	μPD17202A	22	μPD30400	60
μPC4072	122	μPC801	122	μPD16503	117	μPD17203A	22	μPD30401	60
μPC4074	122	μPC802	122	μPD16506	117	μPD17204	22	μPD30410	60
μPC4081	122	μPC803	122	μPD16510	117	μPD17207	22	μPD30412	60
μPC4082	122	μPC804	122	μPD16601	108	μPD1720A	23	μPD30450	60
μPC4084	122	μPC8100	174	μPD16620	108	μPD1721	23	μPD31441	61
μPC4250	122	μPC8104	102,104,170	μPD16622	108	μPD17215	22	μPD31442	61
μPC451	122	μPC8105	102,170	μPD16623	108	μPD17216	22	μPD3150	104
μPC452	122	μPC8106	102,104,174	μPD16624	108	μPD17217	22	μPD3594	98
μPC454	122	μPC8109	104,174	μPD16625	108	μPD17218	22	μPD35H71A	98
μPC4556	122	μPC811	122	μPD16629	108	μPD1723	23	μPD35H74	98
μPC4557	122	μPC8110	170	μPD16630	108	μPD17707	19	μPD3723	98
μPC4558	122	μPC812	122	μPD16640	108	μPD17708	19	μPD3725D-01	98
μPC4559	122	μPC813	122	μPD16641	108	μPD17709	19	μPD3726	98
μPC4560	122	μPC814	122	μPD16650	108	μPD17P001	19	μPD3727	98
μPC4570	122	μPC815	122	μPD16661	108	μPD17P005	19	μPD3732	98
μPC4572	122	μPC816	122	μPD16666	108	μPD17P006A	19	μPD3733	98
μPC4574	122	μPC821	122	μPD16670	107	μPD17P010	19	μPD3734	98
μPC458	122	μPC822	122	μPD16675	107	μPD17P012	19	μPD3737	98
μPC4741	122	μPC824	122	μPD16676	107	μPD17P068	20	μPD3743	98
μPC494	125	μPC831	122	μPD16676A	107	μPD17P103	21	μPD3753	98
μPC5020	94	μPC832	122	μPD16804	109,159	μPD17P104	21	μPD42101	82,109
μPC5021	94	μPC834	122	μPD16805	109,159	μPD17P107	21	μPD42102	82,109
μPC5022	94	μPC842	122	μPD16812A	159	μPD17P108	21	μPD4216160	65
μPC5023	94	μPC844	122	μPD16823	109,159	μPD17P132	21	μPD4216160L	66
μPC5024	94	μPD16300	108	μPD17001	19	μPD17P133	21	μPD4216161	67
μPC5031	94	μPD16301	108	μPD17003A	19	μPD17P136A	21	μPD4216161L	68
μPC5032	94	μPD16302	108	μPD17005	19	μPD17P137A	21	μPD4216400	65

Quick Reference Table by Type Number

Type number	Page	Type number	Page	Type number	Page	Type number	Page	Type number	Page
μPD42164005L	68	μPD42S64400	64	μPD6122-001	117	μPD65650	84	μPD65909	88
μPD4216400L	66	μPD42S64800	64	μPD6133	24	μPD65651	84	μPD65910	88
μPD4216405	67	μPD42S65160	64	μPD6134	24	μPD65652	84	μPD65911	88
μPD4216800	65	μPD42S65400	64	μPD61F35	24	μPD65654	84	μPD65913	88
μPD4216800L	66	μPD42S65800	64	μPD6211	119	μPD65655	84	μPD65915	88
μPD4217400	65	μPD431000A	75	μPD6252	80	μPD65656	84	μPD65917	88
μPD4217400L	66	μPD431000A-B15	75	μPD6253	80	μPD65658	84	μPD65919	88
μPD4217401	67	μPD431008	76	μPD6254	80	μPD65662	84	μPD65926	88
μPD4217401L	68	μPD431008L	76	μPD6255	80	μPD65664	84	μPD65927	88
μPD4217800	65	μPD431009	76	μPD6257	80	μPD65672	84	μPD65928	88
μPD4217800L	66	μPD431009L	76	μPD6258	80	μPD65676	84	μPD65929	88
μPD4217801	67	μPD431016	76	μPD6272	80	μPD65800	85	μPD65930	88
μPD4217801L	68	μPD431016L	76	μPD6273	80	μPD65801	85	μPD65931	88
μPD4218160	65	μPD431018	76	μPD6274	80	μPD65802	85	μPD65933	88
μPD4218160L	66	μPD431018L	76	μPD63	24	μPD65803	85	μPD65935	88
μPD4218161	67	μPD431232L	76	μPD6300	106	μPD65804	85	μPD65937	88
μPD4218161L	68	μPD43256B	75	μPD6316	99	μPD65806	85	μPD65939	88
μPD42280	82,109	μPD43256B-A10	75	μPD6320	106,108,109	μPD65808	85	μPD66001	90
μPD424210	70	μPD43256B-A12	75	μPD63200	111	μPD65810	85	μPD66002	90
μPD424210AL	70	μPD43256B-B12	75	μPD6321	106,108,109	μPD65811	85	μPD66004	90
μPD424260	69	μPD43257B	75	μPD63210	111	μPD65812	85	μPD66006	90
μPD424260AL	69	μPD434004	76	μPD6322	109	μPD65813	85	μPD66008	90
μPD424400	69	μPD434008	76	μPD6323B	106	μPD65823	87	μPD66010	90
μPD424400-L	69	μPD4516161	71	μPD6325	119	μPD65825	87	μPD66011	90
μPD424800	69	μPD4516421	71	μPD6326	119	μPD65826	87	μPD66012	90
μPD426171	82	μPD4516821	71	μPD6335	119	μPD65828	87	μPD66024	90
μPD426174	82	μPD461008	77	μPD6336	119	μPD65830	87	μPD66026	90
μPD42641	82	μPD461016L	77	μPD6337	108	μPD65831	87	μPD66028	90
μPD42641-L	82	μPD461018L	77	μPD6340	106	μPD65832	87	μPD66030	90
μPD4264160	64	μPD461318	77	μPD6345	109	μPD65833	87	μPD66031	90
μPD42644	82	μPD461336	77	μPD63701	105	μPD65835	87	μPD66032	90
μPD42644-L	82	μPD46258	77	μPD63702	111	μPD65838	87	μPD6604	24
μPD4264400	64	μPD46259L	77	μPD63703	111	μPD65840	85	μPD66041	91
μPD4264800	64	μPD4701A	118	μPD63721	105	μPD65841	85	μPD66042	91
μPD4265160	64	μPD4702	118	μPD6376	111	μPD65842	85	μPD66044	91
μPD4265400	64	μPD4704	118	μPD6378A	105	μPD65843	85	μPD66046	91
μPD4265800	64	μPD4711B	119	μPD6379	111	μPD65845	85	μPD66048	91
μPD42S16160	65	μPD4712	119	μPD6382	111	μPD65846	86	μPD66050	91
μPD42S16160L	66	μPD4713A	119	μPD6383	111	μPD65848	86	μPD66051	91
μPD42S16161	67	μPD4714A	119	μPD6384	111	μPD65849	86	μPD66052	91
μPD42S16161L	68	μPD4715A	119	μPD64	24	μPD65850	86	μPD66064	91
μPD42S16400	65	μPD4721	119	μPD6450	115	μPD65851	86	μPD66066	91
μPD42S16400L	66	μPD4722	119	μPD6451A	115	μPD65852	86	μPD66068	91
μPD42S16401L	68	μPD4723	119	μPD6453	115	μPD65853	86	μPD66070	91
μPD42S16405	67	μPD4724	119	μPD6454	115	μPD65855	86	μPD66071	91
μPD42S16800	65	μPD4726	119	μPD6456	115	μPD65858	86	μPD66072	91
μPD42S16800L	66	μPD481440	81	μPD6458	115	μPD65859	86	μPD66081	90
μPD42S17400	65	μPD481850	81	μPD6461	115	μPD65860	86	μPD66082	90
μPD42S17400L	66	μPD482234	81	μPD6462	115	μPD65861	86	μPD66084	90
μPD42S17401	67	μPD482235	81	μPD6464	115	μPD65862	86	μPD66086	90
μPD42S17401L	68	μPD482444	81	μPD6465	115	μPD65863	86	μPD66088	90
μPD42S17800	65	μPD482445	81	μPD6466	115	μPD65865	86	μPD66090	90
μPD42S17800L	66	μPD482445L	81	μPD6487	113	μPD65866	86	μPD66091	90
μPD42S17801	67	μPD485505	82	μPD65612	85	μPD65868	86	μPD66092	90
μPD42S17801L	68	μPD485506	82	μPD65622	85	μPD65869	86	μPD66104	90
μPD42S18160	65	μPD488130L	71	μPD65626	85	μPD65870	86	μPD66106	90
μPD42S18160L	66	μPD488170L	71	μPD65630	84	μPD65871	86	μPD66108	90
μPD42S18161	67	μPD4990A	118	μPD65631	84	μPD65872	87	μPD66110	90
μPD42S18161L	68	μPD4991A	118	μPD65632	85	μPD65873	87	μPD66111	90
μPD42S4210	70	μPD4992	118	μPD65636	84	μPD65875	87	μPD66112	90
μPD42S4210AL	70	μPD5205	125	μPD65640	84	μPD65878	87	μPD6700	106
μPD42S4260	69	μPD5555	125	μPD65641	84	μPD65879	87	μPD67021	89
μPD42S4260AL	69	μPD5556	125	μPD65644	84	μPD658XX	102	μPD67031	89
μPD42S4400	69	μPD61000	109	μPD65646	84	μPD65906	88	μPD67050	89
μPD42S4800	69	μPD61010	109	μPD65647	84	μPD65907	88	μPD67070	89
μPD42S64160	64	μPD6121-001	117	μPD65648	84	μPD65908	88	μPD6708	99

Quick Reference Table by Type Number

Type number	Page	Type number	Page	Type number	Page	Type number	Page	Type number	Page
μPD67101	89	μPD72050	105	μPD753017	5	μPD7757	96	μPD78076	40
μPD67240	89	μPD72051	105	μPD753036	7	μPD7758A	96	μPD78076Y	41
μPD67804	89	μPD72064	105	μPD75304	15	μPD7759	96	μPD78078	40
μPD67852	89	μPD72065B	105	μPD75304B	15	μPD77C25	97	μPD78078Y	41
μPD6952	118	μPD72068	105	μPD75306	15	μPD77C25-10	97	μPD78081	43
μPD7001	118	μPD72070	105	μPD75306B	15	μPD77C30	61	μPD78082	43
μPD7002	118	μPD72103	99	μPD75308	15	μPD77P56	96	μPD78094	44
μPD7003	118	μPD72103A	99	μPD75308B	15	μPD780001	29	μPD78095	44
μPD7004	118	μPD72105	99	μPD753104	6	μPD78001B	29	μPD78096	44
μPD70108	55	μPD72107	99	μPD753106	6	μPD78001BY	30	μPD78098A	44
μPD70108H	55	μPD72123	109	μPD753108	6	μPD78002B	29	μPD7810H	26
μPD7011	119	μPD72185	109	μPD75312	15	μPD78002BY	30	μPD7811H	26
μPD70116	55	μPD72186	109	μPD75312B	15	μPD78011B	29	μPD78134	45
μPD70116H	55	μPD72187	109	μPD75316	15	μPD78011BY	30	μPD78134A	45
μPD70136	55	μPD7225	107	μPD75316B	15	μPD78011F	31	μPD78136	45
μPD70136A	55	μPD7227	107	μPD75328	16	μPD78011FY	32	μPD78138	45
μPD70208	55	μPD7228	107	μPD75336	16	μPD78012B	29	μPD78146	45
μPD70208H	55	μPD7228A	107	μPD75402A	12	μPD78012BY	30	μPD78148	45
μPD70216	55	μPD7229	107	μPD754302	3	μPD78012F	31	μPD78212	46
μPD70216H	55	μPD72291	61	μPD754304	3	μPD78012FY	32	μPD78213	46
μPD70236A	55	μPD7229A	107	μPD75512	10	μPD78013	29	μPD78214	46
μPD70270	56	μPD72305	99	μPD75516	10	μPD78013F	31	μPD78217A	46
μPD70280	56	μPD72611	105	μPD75517	10	μPD78013FY	32	μPD78218A	46
μPD703000	59	μPD72691	61	μPD75518	10	μPD78013Y	30	μPD78220	47
μPD703001	59	μPD750004	3	μPD7554A	17	μPD78014	29	μPD78224	47
μPD703002	59	μPD750006	3	μPD7556A	17	μPD78014F	31	μPD78233	47
μPD70320	56	μPD750008	3	μPD7564A	17	μPD78014FY	32	μPD78234	47
μPD70325	56	μPD75004	10	μPD7566A	17	μPD78014Y	30	μPD78237	47
μPD70330	56	μPD75006	10	μPD75P0016	3	μPD78015F	31	μPD78238	47
μPD70335	56	μPD750064	4	μPD75P0076	4	μPD78015FY	32	μPD78243	46
μPD70433	56	μPD750068	4	μPD75P008	10	μPD78016F	31	μPD78244	46
μPD705100	59	μPD75008	10	μPD75P036	11	μPD78016FY	32	μPD78310A	48
μPD70615	57	μPD75028	11	μPD75P048	11	μPD78018F	31	μPD78312A	48
μPD70616	57	μPD7502A	17	μPD75P068	12	μPD78018FY	32	μPD78320	48
μPD70632	57	μPD75036	11	μPD75P108B	9	μPD780204	35	μPD78322	48
μPD70731	59	μPD7503A	17	μPD75P116	9	μPD780205	35	μPD78323	48
μPD70732	59	μPD75048	11	μPD75P117H	9	μPD78023	33	μPD78324	48
μPD70741	59	μPD75064	12	μPD75P216A	13	μPD78024	33	μPD78327	49
μPD70742	59	μPD75066	12	μPD75P218	13	μPD78042A	34	μPD78328	49
μPD70P3000	59	μPD75068	12	μPD75P238	14	μPD78043A	34	μPD78330	49
μPD70P3002	59	μPD7507B	17	μPD75P3018	5	μPD78044A	34	μPD78334	49
μPD71011	61	μPD7508B	17	μPD75P3036	7	μPD78045A	34	μPD78350	50
μPD71037	61	μPD75104	9	μPD75P3116	6	μPD78052	36	μPD78350A	50
μPD71051	61	μPD75104A	9	μPD75P316A	15	μPD78052Y	37	μPD78352A	50
μPD71054	61	μPD75106	9	μPD75P316B	15	μPD78053	36	μPD78355	50
μPD71055	61	μPD75108	9	μPD75P328	16	μPD78053Y	37	μPD78356	50
μPD71059	61	μPD75108A	9	μPD75P336	16	μPD78054	36	μPD78362A	51
μPD71071	61	μPD75108F	9	μPD75P402	12	μPD78054Y	37	μPD78365A	51
μPD71082	61	μPD75112	9	μPD75P4308	3	μPD78055	36	μPD78366A	51
μPD71083	61	μPD75112F	9	μPD75P516	10	μPD78055Y	37	μPD78370	52
μPD71084	61	μPD75116	9	μPD75P518	10	μPD78056	36	μPD78372	52
μPD71086	61	μPD75116F	9	μPD75P54	17	μPD78056Y	37	μPD784020	52
μPD71087	61	μPD75116H	9	μPD75P56	17	μPD78058	36	μPD784021	52,104
μPD71088	61	μPD75117H	9	μPD75P64	17	μPD78058Y	37	μPD784025	52,104
μPD71101	61	μPD75206	13	μPD75P66	17	μPD78062	38	μPD784026	52,104
μPD71611	61	μPD75208	13	μPD77015	97	μPD78062Y	39	μPD784915	53
μPD71613	61	μPD75212A	13	μPD77016	97	μPD78063	38	μPD78C10A	27
μPD71621	61	μPD75216A	13	μPD77017	97,104	μPD78063Y	39	μPD78C11A	27
μPD71641	61	μPD75217	13	μPD77018	97	μPD78064	38	μPD78C12A	27
μPD72001-11	99	μPD75218	13	μPD77220-10	97	μPD78064Y	39	μPD78C14	27
μPD72001-A8	99	μPD75236	14	μPD77230A	97	μPD78070A	42	μPD78C14A	27
μPD72002-11	99	μPD75237	14	μPD77240	97	μPD78070AY	42	μPD78C17	27
μPD72005	120	μPD75238	14	μPD77501	96	μPD78074	40	μPD78C18	27
μPD72020	109	μPD75268	13	μPD77502	96	μPD78074Y	41	μPD78CG14	27
μPD72042A	99	μPD753012	5	μPD7755	96	μPD78075	40	μPD78CP14	27
μPD72042B	99	μPD753016	5	μPD7756A	96	μPD78075Y	41	μPD78CP18	27

Quick Reference Table by Type Number

Type number	Page	Type number	Page	Type number	Page	Type number	Page	Type number	Page
μPD78P014	29	μPG103	166	NDL5500	184	NDL7601P2	181	PFD142C	194
μPD78P014Y	30	μPG105	166	NDL5506P	184	NDL7610PA	181	PFD161B	194
μPD78P018F	31	μPG106	166	NDL5506PS	184	NDL7650P	182	PFD161C	194
μPD78P018FY	32	μPG107	166	NDL5510	184	NDL7660P	182	PH101	186
μPD78P0208	35	μPG110	166	NDL5516P	184	NDL7670P	182	PH102	186
μPD78P024	33	μPG130	104,166	NDL5520	184	NDL7671P	182	PH103	186
μPD78P048A	34	μPG131	166	NDL5521P	184	NDL7672P	182	PH104	186
μPD78P054	36	μPG132	102,166	NDL5521P2	184	NDL7673P	182	PH105	186
μPD78P054Y	37	μPG501	166	NDL5522P	184	NDL7701P	181	PH106	186
μPD78P058	36	μPG502	166	NDL5530	184	NDL7701P1	181	PH107	186
μPD78P058Y	37	μPG503	166	NDL5551P	184	NDL7701P2	181	PH108	186
μPD78P064	38	μPG504	166	NDL5551P1	184	NDL7710PA	181	PH108A	186
μPD78P064Y	39	μPG506	166	NDL5551P2	184	NE1280100	167	PH109	186
μPD78P078	40	μPG508	166	NDL5553P	184	NE1280200	167	PH110	186
μPD78P078Y	41			NDL5553P1	184	NE1280400	167	PH114	186
μPD78P083	43	[N]		NDL5553P2	184	NE32484A	167	PH116(L)	186
μPD78P098A	44	ND411G-2	177	NDL5561P	184	NE32584C	167	PH302	187
μPD78P138	45	ND412G-2	177	NDL5561P1	184	NE32684A	167	PH302C	187
μPD78P148	45	ND413G-2	177	NDL5561P2	184	NE42484A	167	PH309	187
μPD78P214	46	ND414G-2	177	NDL5590P	184	NE42484C	167	PH310	187
μPD78P218A	46	ND433G	177	NDL5590P1	184	NE6500496	167	PH315	187
μPD78P224	47	ND434G	177	NDL5590P2	184	NE6501077	167	PH320	187
μPD78P238	47	ND487C1-3P	169	NDL7001	181	NE76084	167	PH502HC	188
μPD78P312A	48	ND487C1T	177	NDL7001L	181	NE76184A	167	PH502HR	188
μPD78P322	48	ND487C2-3P	169	NDL7103	182	NE85001	167	PH502LC	188
μPD78P324	48	ND487C2T	177	NDL7113	182	NE85002	167	PH502LR	188
μPD78P328	49	ND487R1T	177	NDL7153	182	NE850R5	167	PH514HC	188
μPD78P334	49	ND487R2T	177	NDL7163	182	NE95001	167	PH514HR	188
μPD78P352	50	NDL3200	181	NDL7401P	181	NE950R2	167	PH514LC	188
μPD78P356	50	NDL3210	181	NDL7401P1	181	NE950R5	167	PH514LR	188
μPD78P364A	51	NDL3210S	181	NDL7401P2	181	NEL2000	168	PH516HC(L)	188
μPD78P368A	51	NDL3215	181	NDL7402P	181	NEZ1414	167	PH516HR(L)	188
μPD78P372	52	NDL3220	181	NDL7402P1	181	NEZ3642	167	PH516LC(L)	188
μPD78P4026	52	NDL3220S	181	NDL7402P2	181	NEZ4450	167	PH516LR(L)	188
μPD78P4916	53	NDL3230	181	NDL7408P1K	181	NEZ5964	167	PH522	188
μPD78PG11H	26	NDL3230SU	181	NDL7408P1L	181	NEZ6472	167	PH525	188
μPD79011	56	NDL3310	181	NDL7408P2K	181	NEZ7177	167	PLD201A	195
μPD79021	56	NDL5100	184	NDL7408P2L	181	NEZ7785	167	PLR101	195
μPD93600	93	NDL5102	184	NDL7408PK	181			PLR102	195
μPD93XXX	92	NDL5131P	184	NDL7408PL	181	[P]		PLR104	195
μPD94600	93	NDL5131P1	184	NDL7409P	181	PFA101A	194	PLR1101	195
μPD94XXX	92	NDL5131P2	184	NDL7409P1	181	PFA112A	194	PLS4001L1	196
μPD951XX	92	NDL5151P	184	NDL7409P2	181	PFA112B	194	PLS4001L2	196
μPD95600	93	NDL5151P1	184	NDL7411RC	181	PFA113A	194	PLT101	195
μPD9604A	100	NDL5151P2	184	NDL7411RD	181	PFA113B	194	PLT102	195
μPD9605A	100	NDL5171P	184	NDL7502P	182	PFA122A	194	PLT104	195
μPD961XX	92	NDL5171P1	184	NDL7503P	182	PFA122B	194	PLT1101	195
μPD9621	100	NDL5171P2	184	NDL7503P1	182	PFA141A	194	PS1001	189
μPD9622	100	NDL5405	183	NDL7510P	182	PFA141B	194	PS2041	190
μPD9624	100	NDL5405C	183	NDL7512P	182	PFA141C	194	PS2043	190
μPD9625	100	NDL5421P	183	NDL7513P	182	PFA141E	194	PS2044	190
μPD96600	93	NDL5421P1	183	NDL7513P1	182	PFA160B	194	PS2501-1	189
μPD98201	99	NDL5421P2	183	NDL7514P	182	PFA160C	194	PS2501-2	189
μPD98203	99	NDL5422P	183	NDL7514P1	182	PFA201A	194	PS2501-3	189
μPD98204	99	NDL5430C	183	NDL7540PA	182	PFA213A	194	PS2501-4	189
μPD98205	99	NDL5430CR	183	NDL7552P	182	PFA222A	194	PS2502-1	189
μPD98309	102	NDL5461P	183	NDL7553P	182	PFA260A	194	PS2502-2	189
μPD98401A	100	NDL5461P1	183	NDL7553P1	182	PFD102A	194	PS2502-3	189
μPD98402A	100	NDL5461P2	183	NDL7560P	182	PFD112A	194	PS2502-4	189
μPD9901	100	NDL5471RC	183	NDL7562P	182	PFD112B	194	PS2503-1	189
μPD9930	104	NDL5471RD	183	NDL7563P	182	PFD114A	194	PS2503-2	189
μPD9935	102	NDL5481P	183	NDL7563P1	182	PFD114B	194	PS2503-3	189
μPD9951	99	NDL5481P1	183	NDL7564P	182	PFD123A	194	PS2503-4	189
μPD9952	99	NDL5481P2	183	NDL7564P1	182	PFD123B	194	PS2505-1	189
μPG100	166	NDL5490	183	NDL7601P	181	PFD142A	194	PS2505-2	189
μPG101	166	NDL5490L	183	NDL7601P1	181	PFD142B	194	PS2505-3	189

Quick Reference Table by Type Number

Type number	Page	Type number	Page	Type number	Page	Type number	Page	Type number	Page
PS2505-4	189	PS2732-2	190	PS5701LC	193	RD15FM	161	RD20M	161
PS2506-1	189	PS2732-4	190	PS5701LR	193	RD15JS	162	RD20P	161
PS2506-2	189	PS2733-1	190	PS5702HC	193	RD15M	161	RD20S	161
PS2506-3	189	PS2733-2	190	PS5702HR	193	RD15P	161	RD20UJ	161
PS2506-4	189	PS2733-4	190	PS5702LC	193	RD15S	161	RD20UM	161
PS2521-1	189	PS2741	190	PS5702LR	193	RD15UJ	161	RD22E	162
PS2521-2	189	PS2801-1	190	PS5732LR-R	193	RD15UM	161	RD22ES	162
PS2521-3	189	PS2801-4	190	PS6001A	193	RD16E	162	RD22F	162
PS2521-4	189	PS2802-1	190	PS6002A	193	RD16ES	162	RD22FM	161
PS2525-1	189	PS2802-4	190	PS8601	190	RD16F	162	RD22JS	162
PS2525-2	189	PS2805-1	190	PS8602	190	RD16FM	161	RD22M	161
PS2525-3	189	PS2805-4	190	PS9601	190	RD16JS	162	RD22P	161
PS2525-4	189	PS2806-1	190	PS9634	190	RD16M	161	RD22S	161
PS2532-1	189	PS2806-4	190	PS9636	190	RD16P	161	RD22UJ	161
PS2532-2	189	PS3601	191	PS9701	190	RD16S	161	RD22UM	161
PS2532-3	189	PS3602	191			RD16UJ	161	RD24E	162
PS2532-4	189	PS3611	191	[R]		RD16UM	161	RD24ES	162
PS2533-1	189	PS3612	191	RD100E	162	RD18E	162	RD24F	162
PS2533-2	189	PS3701	191	RD100P	161	RD18ES	162	RD24FM	161
PS2533-3	189	PS3702	191	RD10E	162	RD18F	162	RD24JS	162
PS2533-4	189	PS3711	191	RD10ES	162	RD18FM	161	RD24M	161
PS2561-1	189	PS3712	191	RD10F	162	RD18JS	162	RD24P	161
PS2561-2	189	PS3901	191	RD10FM	161	RD18M	161	RD24S	161
PS2562-1	189	PS3911	191	RD10JS	162	RD18P	161	RD24UJ	161
PS2562-2	189	PS3912	191	RD10M	161	RD18S	161	RD24UM	161
PS2565-1	189	PS4001	191	RD10P	161	RD18UJ	161	RD27E	162
PS2565-2	189	PS4003	191	RD10S	161	RD18UM	161	RD27ES	162
PS2566-1	189	PS4005	191	RD10UJ	161	RD2.0E	162	RD27F	162
PS2566-2	189	PS4007	191	RD10UM	161	RD2.0ES	162	RD27FM	161
PS2601	189	PS4008	191	RD110E	162	RD2.0F	162	RD27JS	162
PS2602	189	PS4009	191	RD110P	161	RD2.0HS	162	RD27M	161
PS2603	189	PS4010	191	RD11E	162	RD2.0M	161	RD27P	161
PS2604	189	PS4011	191	RD11ES	162	RD2.0P	161	RD27S	161
PS2605	189	PS4015	191	RD11F	162	RD2.0S	161	RD27UJ	161
PS2606	189	PS4016	191	RD11FM	161	RD2.0UM	161	RD27UM	161
PS2607	189	PS4501	191	RD11JS	162	RD2.2E	162	RD3.0E	162
PS2608	189	PS4502	191	RD11M	161	RD2.2ES	162	RD3.0ES	162
PS2621	189	PS4503A	191	RD11P	161	RD2.2F	162	RD3.0F	162
PS2622	189	PS4504A	191	RD11S	161	RD2.2HS	162	RD3.0HS	162
PS2625	189	PS4506	191	RD11UJ	161	RD2.2M	161	RD3.0M	161
PS2626	189	PS4601	192	RD11UM	161	RD2.2P	161	RD3.0MW	161
PS2633	189	PS4602	192	RD120E	162	RD2.2S	161	RD3.0P	161
PS2634	189	PS4602(1)	192	RD120P	161	RD2.2UM	161	RD3.0S	161
PS2651	189	PS4651	192	RD12E	162	RD2.4E	162	RD3.0UM	161
PS2652	189	PS4652	192	RD12ES	162	RD2.4ES	162	RD3.3E	162
PS2653	189	PS4652(1)	192	RD12F	162	RD2.4F	162	RD3.3ES	162
PS2654	189	PS4701	192	RD12FM	161	RD2.4HS	162	RD3.3F	162
PS2701-1	190	PS4702	192	RD12JS	162	RD2.4M	161	RD3.3HS	162
PS2701-2	190	PS4703	192	RD12M	161	RD2.4MW	161	RD3.3M	161
PS2701-4	190	PS4704	192	RD12P	161	RD2.4P	161	RD3.3MW	161
PS2702-1	190	PS4751	192	RD12S	161	RD2.4S	161	RD3.3P	161
PS2702-2	190	PS4752	192	RD12UJ	161	RD2.4UM	161	RD3.3S	161
PS2702-4	190	PS5001HC	193	RD12UM	161	RD2.7E	162	RD3.3UM	161
PS2703-1	190	PS5001HR	193	RD13E	162	RD2.7ES	162	RD3.6E	162
PS2703-2	190	PS5001LC	193	RD13ES	162	RD2.7F	162	RD3.6ES	162
PS2703-4	190	PS5001LR	193	RD13F	162	RD2.7HS	162	RD3.6F	162
PS2705-1	190	PS5002HC	193	RD13FM	161	RD2.7M	161	RD3.6HS	162
PS2705-2	190	PS5002HR	193	RD13JS	162	RD2.7MW	161	RD3.6M	161
PS2705-4	190	PS5002LC	193	RD13M	161	RD2.7P	161	RD3.6MW	161
PS2706-1	190	PS5002LR	193	RD13P	161	RD2.7S	161	RD3.6P	161
PS2706-2	190	PS5003HC	193	RD13S	161	RD2.7UM	161	RD3.6S	161
PS2706-4	190	PS5003HR	193	RD13UJ	161	RD20E	162	RD3.6UM	161
PS2707-1	190	PS5003LC	193	RD13UM	161	RD20ES	162	RD3.9E	162
PS2707-2	190	PS5003LR	193	RD15E	162	RD20F	162	RD3.9ES	162
PS2707-4	190	PS5701HC	193	RD15ES	162	RD20FM	161	RD3.9F	162
PS2732-1	190	PS5701HR	193	RD15F	162	RD20JS	162	RD3.9HS	162

Type number	Page	Type number	Page	Type number	Page	Type number	Page	Type number	Page
RD3.9M	161	RD43E	162	RD68P	161	V30HL	55		
RD3.9MW	161	RD43F	162	RD7.5E	162	V33	55		
RD3.9P	161	RD43FM	161	RD7.5ES	162	V33A	55		
RD3.9S	161	RD43M	161	RD7.5F	162	V35	56		
RD3.9UM	161	RD43P	161	RD7.5FM	161	V35+	56		
RD30E	162	RD47E	162	RD7.5JS	162	V35HS	56		
RD30ES	162	RD47F	162	RD7.5M	161	V40	55		
RD30F	162	RD47FM	161	RD7.5MW	161	V40HL	55		
RD30FM	161	RD47M	161	RD7.5P	161	V41	56		
RD30JS	162	RD47P	161	RD7.5S	161	V50	55		
RD30M	161	RD5.1E	162	RD7.5UJ	161	V50HL	55		
RD30P	161	RD5.1ES	162	RD7.5UM	161	V51	56		
RD30S	161	RD5.1F	162	RD75E	162	V53A	55		
RD30UJ	161	RD5.1FM	161	RD75F	162	V55PI	56		
RD30UM	161	RD5.1JS	162	RD75P	161	V60	57		
RD33E	162	RD5.1M	161	RD8.2E	162	V70	57		
RD33ES	162	RD5.1MW	161	RD8.2ES	162	V805	59		
RD33F	162	RD5.1P	161	RD8.2F	162	V810	59		
RD33FM	161	RD5.1S	161	RD8.2FM	161	V820	59		
RD33JS	162	RD5.1UJ	161	RD8.2JS	162	V821	59		
RD33M	161	RD5.1UM	161	RD8.2M	161	V830	59		
RD33P	161	RD5.6E	162	RD8.2MW	161	V851	59		
RD33S	161	RD5.6ES	162	RD8.2P	161	V852	59		
RD33UJ	161	RD5.6F	162	RD8.2S	161	Vr3010A	61		
RD33UM	161	RD5.6FM	161	RD8.2UJ	161	Vr4000PC	60		
RD36E	162	RD5.6JS	162	RD8.2UM	161	Vr4000SC	60		
RD36ES	162	RD5.6M	161	RD82E	162	Vr4100	60		
RD36F	162	RD5.6MW	161	RD82F	162	Vr4200	60		
RD36FM	161	RD5.6P	161	RD82P	161	Vr4300	60		
RD36JS	162	RD5.6S	161	RD9.1E	162	Vr4400MC	60		
RD36M	161	RD5.6UJ	161	RD9.1ES	162	Vr4400PC	60		
RD36P	161	RD5.6UM	161	RD9.1F	162				
RD36S	161	RD51E	162	RD9.1FM	161	[Z]			
RD36UJ	161	RD51F	162	RD9.1JS	162	Z80	104		
RD36UM	161	RD51FM	161	RD9.1M	161				
RD39E	162	RD51P	161	RD9.1MW	161				
RD39ES	162	RD56E	162	RD9.1P	161				
RD39F	162	RD56F	162	RD9.1S	161				
RD39FM	161	RD56P	161	RD9.1UJ	161				
RD39JS	162	RD6.2E	162	RD9.1UM	161				
RD39M	161	RD6.2ES	162	RD91E	162				
RD39P	161	RD6.2F	162	RD91P	161				
RD39S	161	RD6.2FM	161						
RD39UJ	161	RD6.2JS	162	[S]					
RD39UM	161	RD6.2M	161	SE1003-C	185				
RD4.3E	162	RD6.2MW	161	SE1103	185				
RD4.3ES	162	RD6.2P	161	SE301A	185				
RD4.3F	162	RD6.2S	161	SE302A	185				
RD4.3HS	162	RD6.2UJ	161	SE303	185				
RD4.3M	161	RD6.2UM	161	SE303A-C	185				
RD4.3MW	161	RD6.8E	162	SE304	185				
RD4.3P	161	RD6.8ES	162	SE306	185				
RD4.3S	161	RD6.8F	162	SE307-C	185				
RD4.3UM	161	RD6.8FM	161	SE308	185				
RD4.7E	162	RD6.8JS	162	SE310	185				
RD4.7ES	162	RD6.8M	161	SE313	185				
RD4.7F	162	RD6.8MW	161	SE314	185				
RD4.7FM	161	RD6.8P	161	SE316(L)	185				
RD4.7HS	162	RD6.8S	161						
RD4.7JS	162	RD6.8UJ	161	[V]					
RD4.7M	161	RD6.8UM	161	V20	55				
RD4.7MW	161	RD62E	162	V20HL	55				
RD4.7P	161	RD62F	162	V25	56				
RD4.7S	161	RD62P	161	V25+	56				
RD4.7UJ	161	RD68E	162	V25HS	56				
RD4.7UM	161	RD68F	162	V30	55				

For further information, please contact:

NECCorporation

NEC Building
7-1, Shiba 5-chome, Minato-ku
Tokyo 108-01, Japan
Tel: 03-3454-1111
Tlx: 22686
Fax: 03-3798-6059

[North & South America]

NEC Electronics Inc.

475 Ellis Street
Mountain View, CA 94043-2203
Tel: 415-965-6776
800-366-9782
Tlx: 171090
Fax: 415-965-6077
800-729-9288

[Regional Sales Offices]

Central Region

Greenspoint Tower
2800 West Higgins
Road Suite 765
Hoffman Estates,
IL 60195
Tel: 708-519-3930
Fax: 708-519-9329

Norcal Region

4677 Old Ironsides Dr. Suite 450
Santa Clara, CA 95054, U.S.A.
Tel: 408-986-1020
Fax: 408-988-4165

Eastern Region

901 Lake Destiny Drive
Suite 320
Maitland, FL 32751, U.S.A.
Tel: 407-875-1145
Fax: 407-875-0962

Western Region

One Embassy Centre
9020 S.W. Washington
Square Road
Suite 400
Tigard, OR 97223, U.S.A.
Tel: 503-671-0177
Fax: 503-643-5911

NEC do Brasil S.A.

Rua Rui Barbosa, N. 294
Bela Vista CEP 01326-010
São Paulo-SP, Brasil
Tel: 011-251-2266
Fax: 011-251-0735

[Europe]

NEC Electronics (Germany) GmbH

Kanzler Str.2,
40472 Düsseldorf
Germany
Tel: 0211-650302
Tlx: 8589960 NE D
Fax: 0211-6503490

Munich Office

Arabellastr. 17
D-81925 München, Germany
Tel: 089-921003-0
Tlx: 522971 NECGM D
Fax: 089-913182

Stuttgart Office

Villastr. 1
D-70190 Stuttgart, Germany
Tel: 0711-16669-0
Fax: 0711-16669-19

Hannover Office

Koenigstr. 12
D-30175 Hannover, Germany
Tel: 0511-33402-0
Tlx: 9230109 NECH D
Fax: 0511-33402-24

Benelux Office

Boschdijk 187a
NL-5612 HB Eindhoven,
The Netherlands
Tel: 040-445845
Tlx: 51923 NEC B NL
Fax: 040-444580

Scandinavia Office

P.O.Box 134
S-18322 Taeby
Tel: 08-6380820
Tlx: 13839NECSCAN S
Fax: 08-6380388

NEC Electronics (UK) Limited

Cygnus House, Sunrise Park Way,
Milton Keynes, MK14 6NP, U.K.
Tel: 1908-691-133
Tlx: 826791
Fax: 1908-670-290

NECElectronics (France) S.A.

9, rue Paul Dautier-BP 187
78142 Velizy-Villacoublay Cedex
France
Tel: 1-30-67-58-00
Tlx: 699499F
Fax: 1-39-46-36-63

Madrid Office

Juan Esplandiú, 15
28007 Madrid, Spain
Tel: 1-504-2787
Fax: 1-504-2860

NECElectronics Italiana s.r.l.

Via Fabio Filzi, 25/A,
20124 Milano, Italy
Tel: 02-6709108
Tlx: 315355
Fax: 02-66981329

[Asia & Oceania]

NECElectronics Hong Kong Limited

12/F., Cityplaza 4, 12 Taikoo
Wan Road, Hong Kong
Tel: 2886-9318
Tlx: 54561
Fax: 2886-9022/9044

Seoul Branch

Room 501, Korea City Air-Terminal Bldg.
159-6, Samsung-Dong, Kangnam-Ku
Seoul, the Republic of Korea
Tel: 02-551-0450
Fax: 02-551-0451

NECElectronics Taiwan Ltd.

7F, No. 363 Fu Shing North Road
Taipei, Taiwan
Tel: 02-719-2377
Tlx: 22372
Fax: 02-719-5951

NECElectronics Singapore Pte. Ltd.

101 Thomson Road #04-02/05
United Square, Singapore 307591
Tel: 253-8311
Fax: 250-3583

G95.9

Document No. X10679EJAV0SG00 (10th edition)

(Previous No. MF-1134)

Date published October 1995P