

AN7148

Dual 2.1W Audio Power Amplifier Circuit

■ Overview

The AN7148 is an integrated circuit designed for power amplifier of 2.1W (9V, 4Ω) output. Stereo operation is enabled due to incorporating two amplifiers on one chip. It is most suitably used for battery operated set such as radio cassette recorder because quiescent circuit current is small comparing to current power amplifier. Low distortion and low noise are realized and external components are very few. 12-pin SIP package has realized compact and high density mounting of a set.

■ Features

- Low quiescent current
- High operation stability
- Low radiation
- Low distortion
- Low noise
- Low shock noise from power ON/OFF operation
- Fewer external components

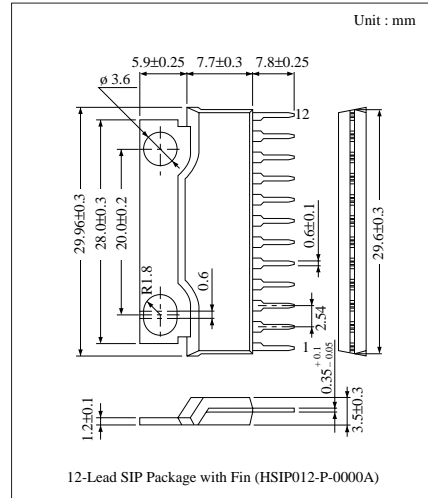

■ Pin Descriptions

Pin No.	Pin Name	Pin No.	Pin Name
1	N.F.B Ch.1	7	Output Ch.2
2	Input Ch.1	8	Bootstrap Ch.2
3	Ripple Filter	9	GND (Output)
4	GND (Input)	10	V _{CC}
5	Input Ch.2	11	Bootstrap Ch.1
6	N.F.B Ch.2	12	Output Ch.1

■ Block Diagram

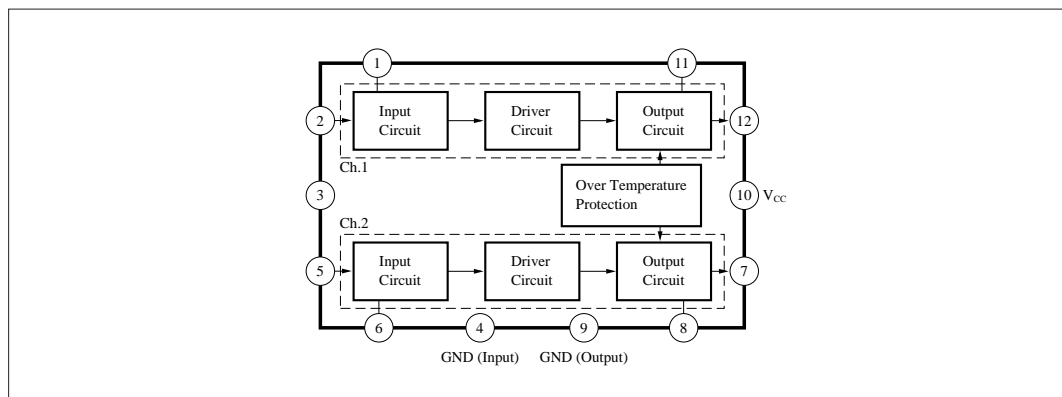

■ Absolute Maximum Ratings (Ta= 25°C)

Parameter	Symbol	Rating	Unit
Supply Voltage	V _{CC}	24	V
Supply Current	I _{CC}	3.5	A
Power Dissipation	P _D *	41.7	W
Operating Ambient Temperature	T _{opr}	- 30 ~ + 75	°C
Storage Temperature	T _{stg}	- 55 ~ + 150	°C

* R_{θj-c} = 3°C/W

■ Electrical Characteristics (Ta= 25°C)

Parameter	Symbol	Condition	min.	typ.	max.	Unit
Quiescent Circuit Current	I _{CQ}	V _{CC} = 9V, R _L = 4Ω, V _{in} = 0mV	—	13	19	mA
Output Noise Voltage	V _{no} *	V _{CC} = 9V, R _L = 4Ω, V _{in} = 0mV, R _g = 10kΩ	—	0.25	0.50	mV
Voltage Gain (Gain)	G _V	V _{CC} = 9V, R _L = 4Ω, V _{in} = 3mV, f = 1kHz	42.5	44.5	46.5	dB
Total Harmonic Distortion	THD	V _{CC} = 9V, R _L = 4Ω, V _{in} = 3mV, f = 1kHz	—	0.20	0.75	%
Maximum Output Power (4Ω)	P _{O(max.)}	V _{CC} = 9V, R _L = 4Ω, THD = 10%, f = 1kHz	1.75	2.10	—	W
Channel Balance	CB	V _{CC} = 9V, R _L = 4Ω, V _{in} = 3mV, f = 1kHz	—	0	1	dB
Maximum Output Power (8Ω)	P _{O(max.)} 8	V _{CC} = 9V, R _L = 8Ω, THD = 10%, f = 1kHz	—	1.25	—	W
Maximum Output Power (3Ω)	P _{O(max.)} 3	V _{CC} = 9V, R _L = 3Ω, THD = 10%, f = 1kHz	—	2.6	—	W

Note) Operating Supply Voltage Range : V_{CC(oper.)} = 6 ~ 18V

* Filter with band width of 15Hz ~ 30kHz (12dB/oct) should be used for V_{no} measurement.

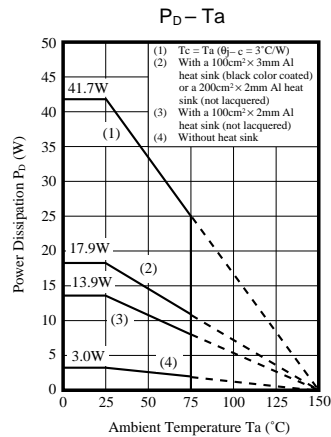

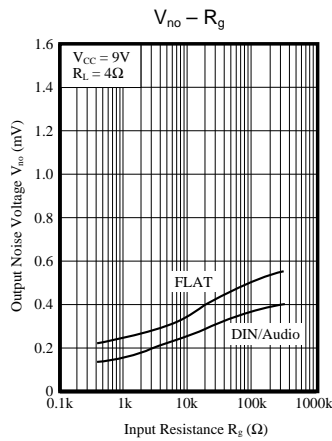
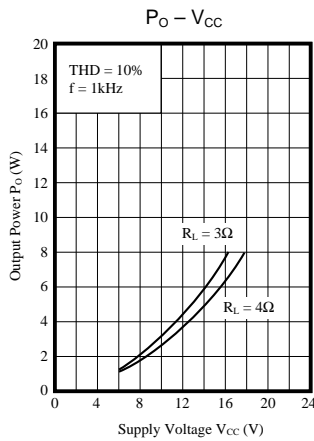
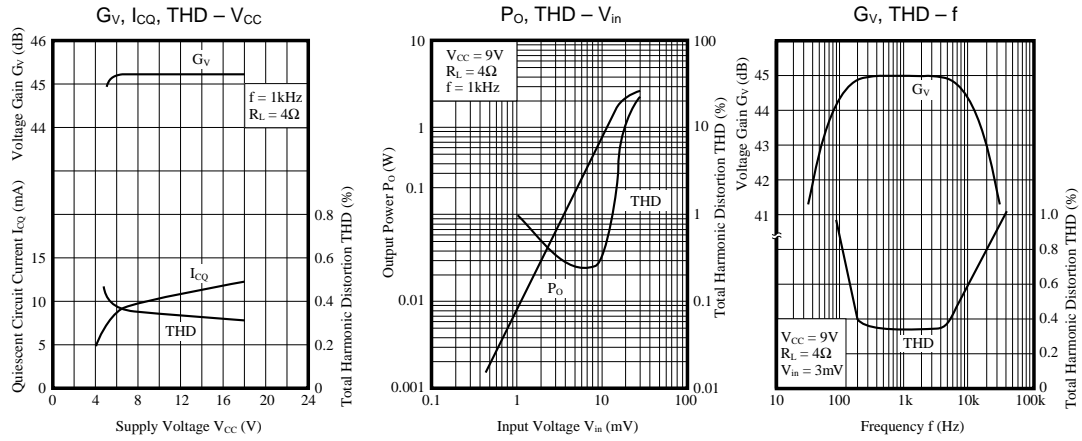

■ Application Circuit

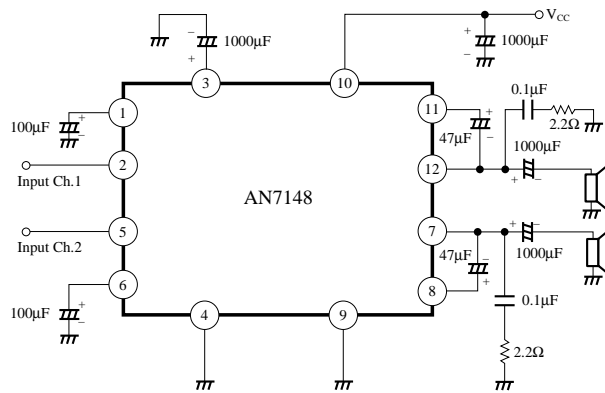

■ Printed Circuit Board Layout

