

SONY®

# CXA1019M/P/S

## FM/AM Radio

### Description

CXA1019M/P/S is a one-chip FM/AM radio IC designed for radio-cassette tape recorders and headphone tape recorders, and has the following functions.

### Features

- Small number of peripheral components.
- Low current consumption ( $V_{CC}=3V$ )
  - For FM:  $I_D=5.3$  mA (Typ.)
  - For AM:  $I_D=3.4$  mA (Typ.)
- Built-in FM/AM select switch.
- Large output of AF amplifier.
  - $V_{CC}=6V$ , EIAJ output=500 mW (Typ.) when
  - $V_{CC}=6V$ , load impedance  $8\Omega$

### Functions

#### FM section

- RF amplifier, Mixer and OSC (incorporating AFC variable capacitor).
- IF amplifier
- Quadrature detection
- Tuning LED driver

#### AM section

- RF amplifier, Mixer and OSC (with RF AGC).
- IF amplifier (with IF AGC)
- Detector
- Tuning LED driver

#### AF section

- Electronic volume control

### Structure

Bipolar silicon monolithic IC

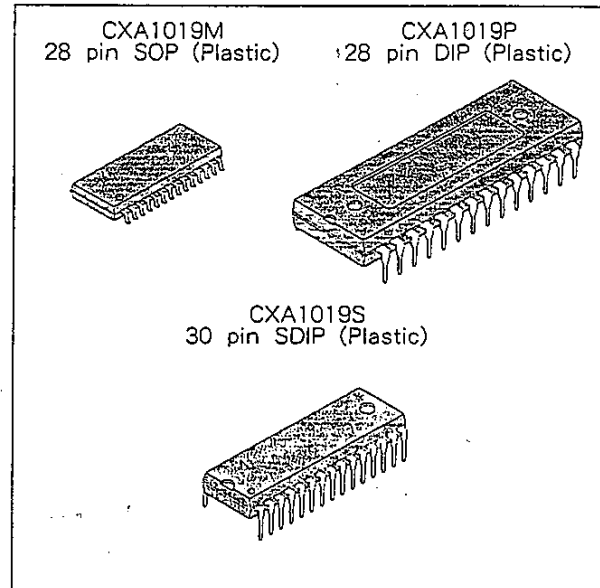

**Recommended Operating Conditions**

• Supply voltage	V <sub>cc</sub>	2 to 7.5	V (CXA1019M)
	V <sub>cc</sub>	2 to 8.5	V (CXA1019P/S)

**Absolute Maximum Ratings (Ta=25°C)**

• Supply voltage	V <sub>cc</sub>	9	V
• Operating temperature	T <sub>opr</sub>	-10 to +60	°C
• Storage temperature	T <sub>stg</sub>	-50 to +125	°C
• Allowable power dissipation	P <sub>d</sub> CXA1019M	700	mW
	CXA1019P/S	1000	mW

**Block Diagram  
CXA1019M/P**

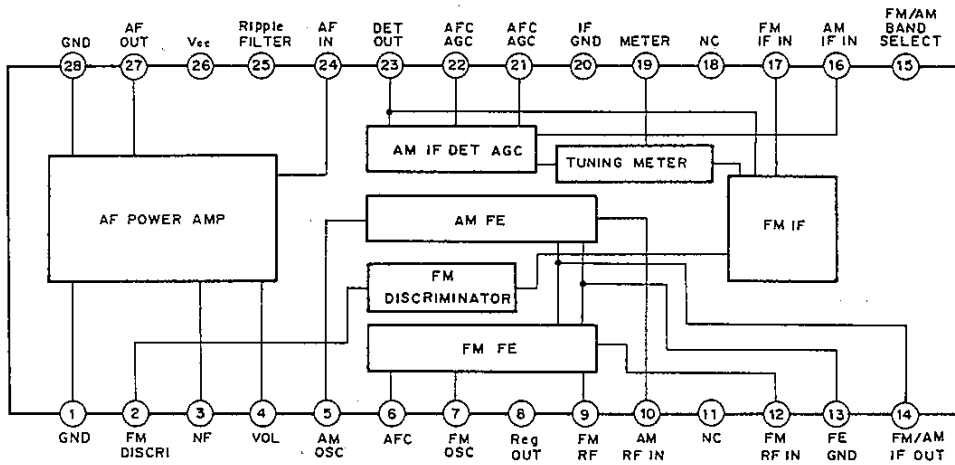

**CXA1019S**

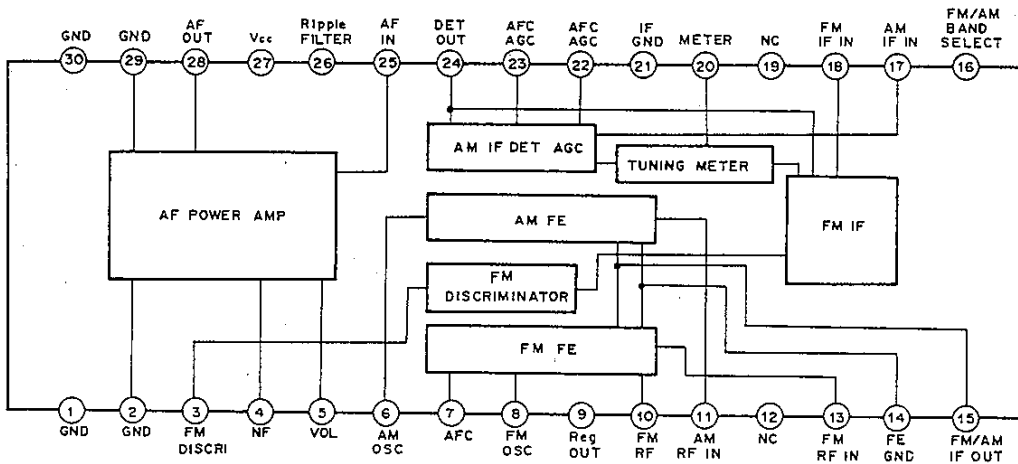

Standard Circuit Design Data

(The pin numbers in the parenthesis are for CXA1019S.)

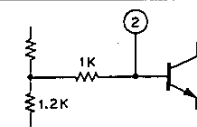
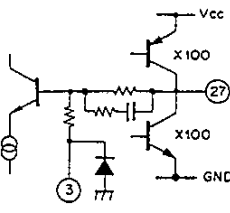
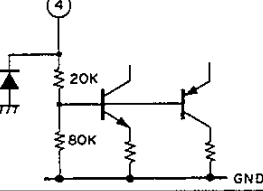
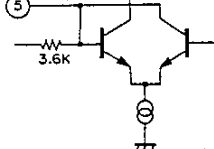
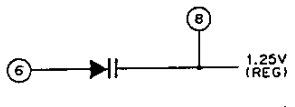
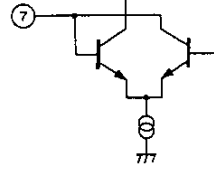
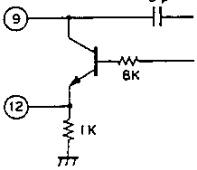
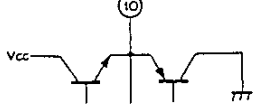
No.	Symbol	Voltage (V)				Equivalent circuit	Description
		Vcc=3V		Vcc=6V			
		FM	AM	FM	AM		
1 (1, 2)	GND	0	0	0	0		
2 (3)	FM DISCRI	2.18	2.70	4.88	5.43		Phase-shift circuit Connect ceramic discriminator
3 (4)	NF	1.5	1.5	3.0	3.0		Negative feedback pin
27 (28)	AF OUT	1.5	1.5	3.0	3.0		Power amplifier output pin
4 (5)	VOL CONT	1.25	1.25	1.25	1.25		Connect variable resistor for electronic volume control.
5 (6)	AM OSC	1.25	1.25	1.25	1.25		AM local oscillation circuit
6 (7)	AFC	1.25	*	1.25	*		AFC variable capacitor pin
8 (9)	REG OUT	1.25	1.25	1.25	1.25		Regulator pin 1.25V (Typ.)
7 (8)	FM OSC	1.25	1.25	1.25	1.25		FM local oscillation circuit
9 (10)	FM RF	1.25	1.25	1.25	1.25		Connect FM RF tuning coil.
12 (13)	FM RF IN	0.3	0	0.3	0		FM RF input pin
10 (11)	AM RF IN	1.25	1.25	1.25	1.25		AM RF input pin

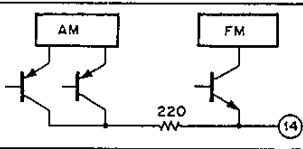
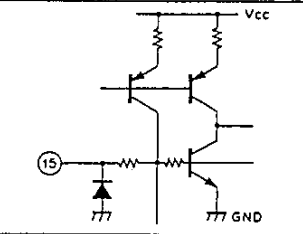
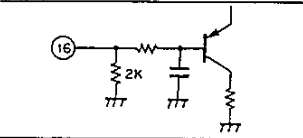
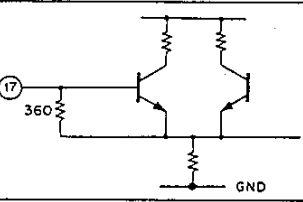
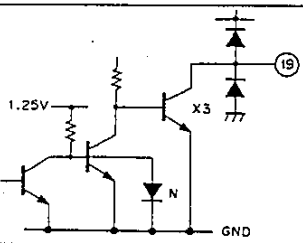
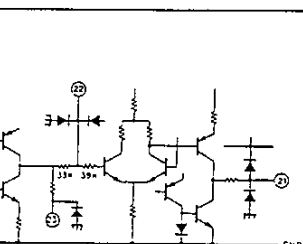
No.	Symbol	Voltage (V)				Equivalent circuit	Description
		Vcc=3V		Vcc=6V			
		FM	AM	FM	AM		
11 (12)	NC	0	0	0	0		
13 (14)	GND (FE GND)	0	0	0	0		
14 (15)	FM/AM FE OUT	0.36	0.2	0.36	0.2		IF output pin of FM and AM. Connect IF filter.
15 (16)	BAND SELECT	1.30	0	1.30	0		FM and AM bands selection switch pin. During GND it becomes AM and during open it becomes FM.
16 (17)	AM IF IN	0	0	0	0		Input pin of AM IF.
17 (18)	FM IF IN	0.34	0	0.88	0		Input pin of FM IF.
18 (19)	NC	0	0	0	0		
19 (20)	METER	3.0	3.0	6.0	6.0		Meter drive circuit (For tuning indicator)
20 (21)	GND	0	0	0	0		
21 (22)	AFC/AGC	1.25	1.49	1.25	1.49		AFC pin of W band. During AM, it determines time constant of AGC.
22 (23)	AFC/AGC	1.25	1.12	1.25	1.15		AFC pin of J band. During AM, it determines time constant of AGC.
23 (24)	DET OUT	1.25	1.0	1.25	1.0		Detection output pin

No.	Symbol	Voltage (V)				Equivalent circuit	Description
		Vcc=3V		Vcc=6V			
		FM	AM	FM	AM		
24 (25)	AF IN	0	0	0	0		Power amplifier input pin
25 (26)	RIPPLE FILTER	2.71	2.71	5.4	5.4		Ripple filter
26 (27)	Vcc	3.0	3.0	6.0	6.0		Power supply pin
28 (29, 30)	GND	0	0	0	0		Power GND

\* **Note**) The pin voltage of pin 6 during AM, it is the same pin voltage of pin 22 (23) during J BAND and is the same pin voltage of pin 21 (22) during W BAND.

## Electrical Characteristics

See the Electrical Characteristics Test Circuit  
Ta=25°C, Vcc=6V

No.	Item	Symbol	SW conditions						Test Point	Conditions	Min.	Typ.	Max.	Unit
			1	2	3	4	5	6						
1	AM circuit current	ID1	A	B	A	A	A	A	IA	No signal, AM	—	3.5	10.0	mA
2	FM circuit current	ID2	A	B	A	A	B	A	IA	No signal, FM	—	7.0	14.0	mA
3	FM front end voltage gain	GV1	A	B	A	A	B	A	VA	V <sub>IN1</sub> =40dBμV, 100MHz	32	39	46	dB
4	FM detection output level	VD1	A	—	—	A	B	A	VD	V <sub>IN3</sub> =90dBμV, 10.7MHz (1kHz, 22.5kHz DEV)	39	77.5	155	V <sub>rms</sub>
5	FM IF knee level	VD2	A	—	—	A	B	A	VD	V <sub>IN3</sub> level at a point 3dB down from V <sub>IN3</sub> =90dBμV, 10.7MHz (1kHz, 22.5kHz DEV)	—	24	32	dBμV
6	FM detection output distortion factor	THD1	A	—	—	A	B	A	VD	V <sub>IN3</sub> =90dBμV, 10.7MHz (1kHz 75kHz DEV)	—	0.3	2.0	%
7	FM meter current	IB1	A	—	—	A	B	A	IM	V <sub>IN3</sub> =60dBμV, 10.7MHz	1.8	3.5	7.0	mA
8	AM front end voltage gain	GV2	A	A	A	A	A	A	VB	V <sub>IN2</sub> =60dBμV, 1660kHz	15	22	29	dB
9	AM IF voltage gain	GV3	A	A	—	A	A	A	VD	V <sub>IN4</sub> when 455kHz (1kHz 30% MOD) output is -34dBm	14	20	27	dBμV
10	AM detection output level	VD3	A	A	—	A	A	A	VD	V <sub>IN4</sub> =85dBμV, 455kHz (1kHz, 30% MOD)	39	77.5	155	V <sub>rms</sub>
11	AM meter current	IB2	A	A	—	A	A	A	IM	V <sub>IN4</sub> =85dBμV, 455kHz	1.3	3.0	7.0	mA
12	AM detection output distortion factor	THD2	A	A	B	B	A	A	VD	V <sub>IN2</sub> =95dBμV, 1660kHz (1kHz, 30% MOD) V <sub>CC</sub> =7.8V	—	0.6	2.0	%
13	Audio voltage gain	GV4	A	—	—	—	—	B	VE	V <sub>IN4</sub> =-30dBm, 1kHz	27	31.5	36	dB
14	Audio distortion factor	THD3	A	—	—	—	—	B	VE	Distortion factor for output of 50mW V <sub>IN4</sub> =-20dBm, 1kHz	—	0.3	2.5	%

0dBμV=1μV

Electrical Characteristic Test Circuit

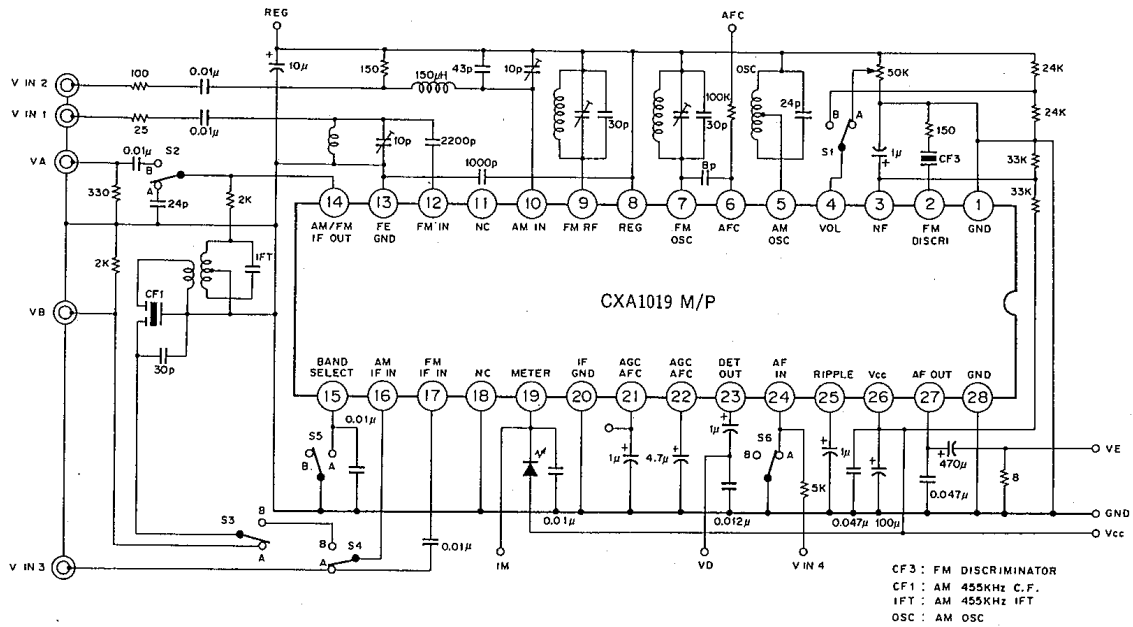
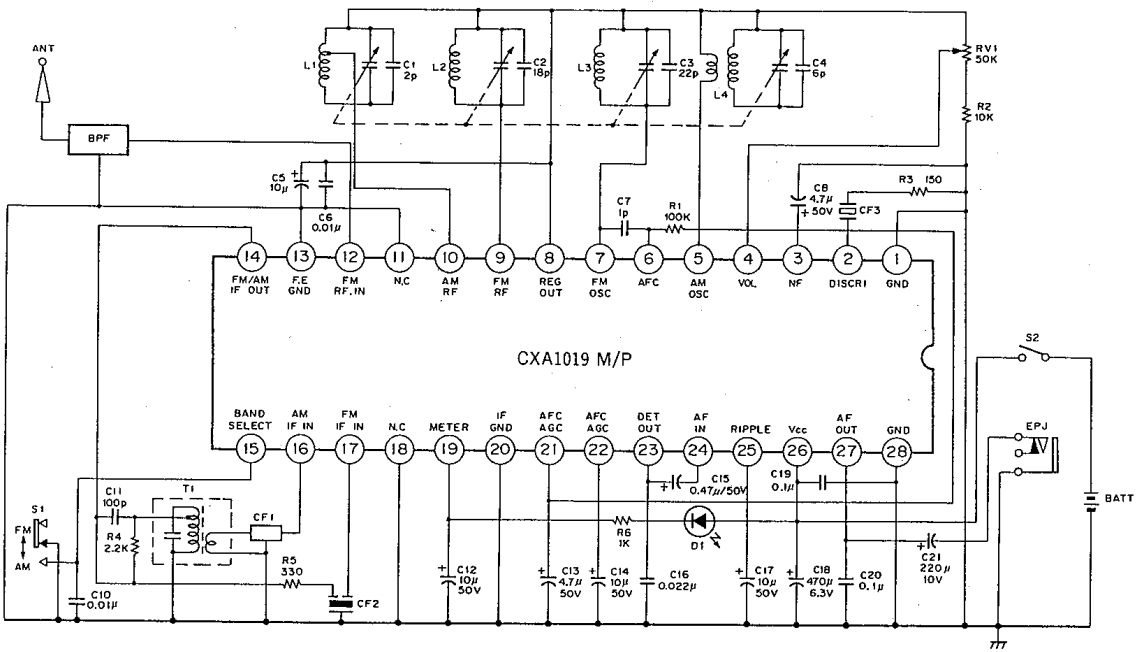

Fig. 2

Application Circuit 1



SONY®

CXA1019M/P/S



Application Circuit 2

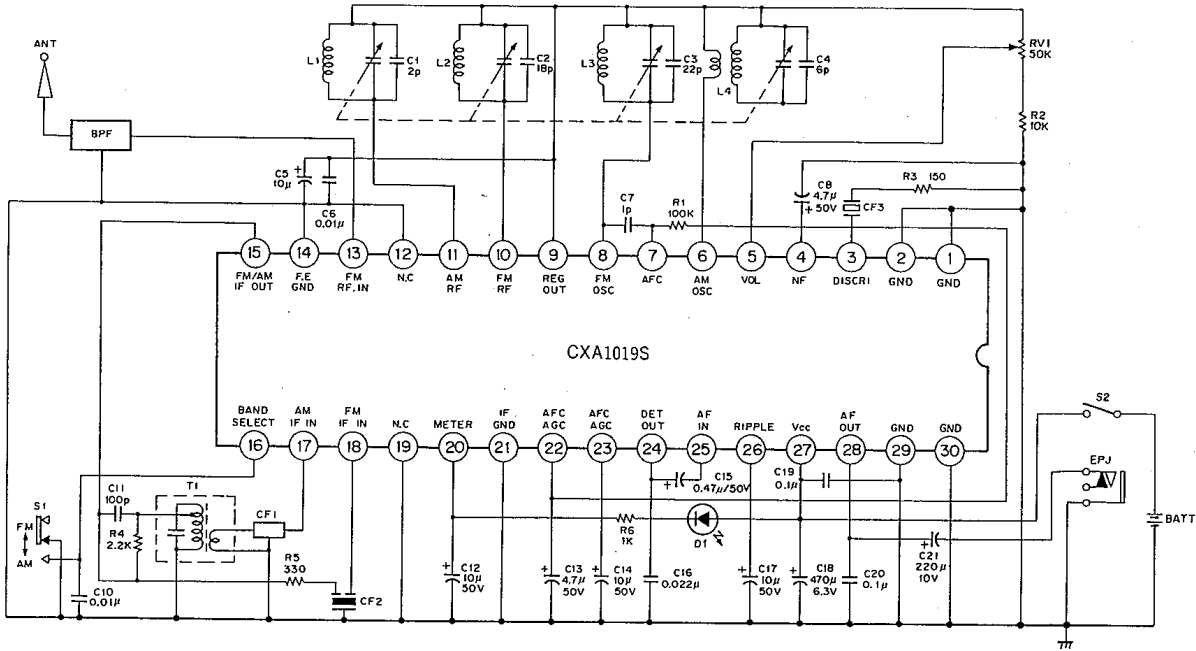

**Coil data**  
AM OSC

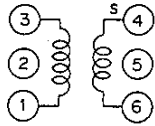

Core diameter  $\phi 0.06$  mm 2UEW

f(kHz)	L( $\mu$ H)	Q <sub>o</sub>	Number of windings t	
			1 to 3	4 to 6
796	270	125	107	29

Equivalent to L-5K7-H5 R12-1684X. Mitsumi Electric Co., Ltd.  
or 7TRS-8441X TOKO Co., Ltd.

**AM IFT**

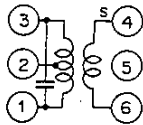

Core diameter  $\phi 0.07$  mm UEW

Co(pF)	Q <sub>o</sub>	Number of windings t		
		1 to 2	2 to 3	4 to 6
180	90	111	35	7

Equivalent to 21K7-H5 R12-8558A. Mitsumi Electric Co., Ltd.  
or 7MC-7789N TOKO Co., Ltd.

**FM RF**

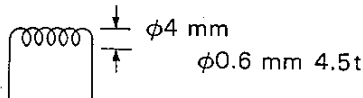

**FM OSC**

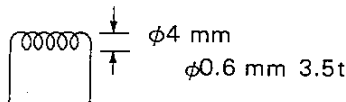

**AM bar antenna**

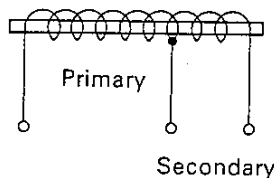

f(kHz)	L( $\mu$ H)	Primary	Secondary
796	650	91t	20t

**BPF**

**PFWEB**

(88 to 108 MHz) Soshin Electric Co., Ltd.

**CF1**

**SFU-455B**

Murata Mfg. Co., Ltd. Or BFCFL-455 TOKO Co., Ltd.

**CF2**

**SFE10.7MA5**

Murata Mfg. Co., Ltd.

**CF3**

**CDA10.7MC1**

Murata Mfg. Co., Ltd.

CXA1019M Evaluation Board

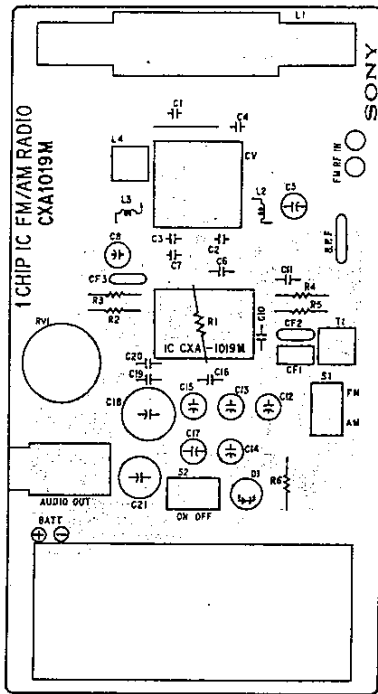

Parts arrangement diagram

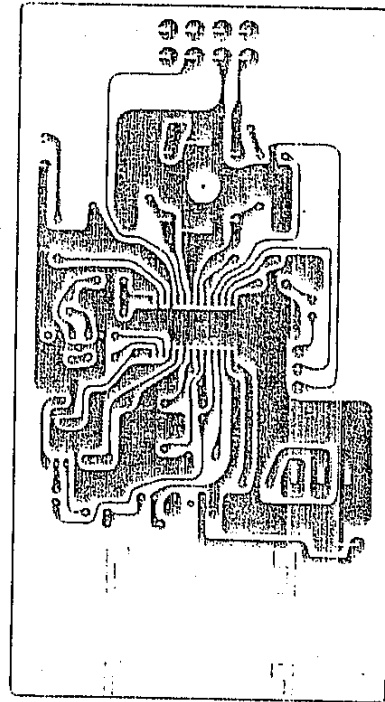

Pattern diagram

CXA1019P Evaluation Board

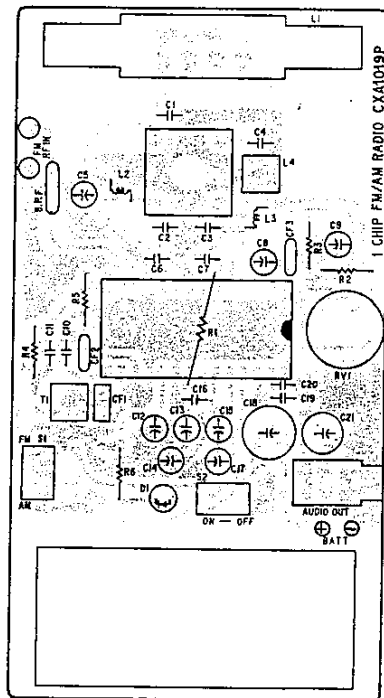

Parts arrangement diagram

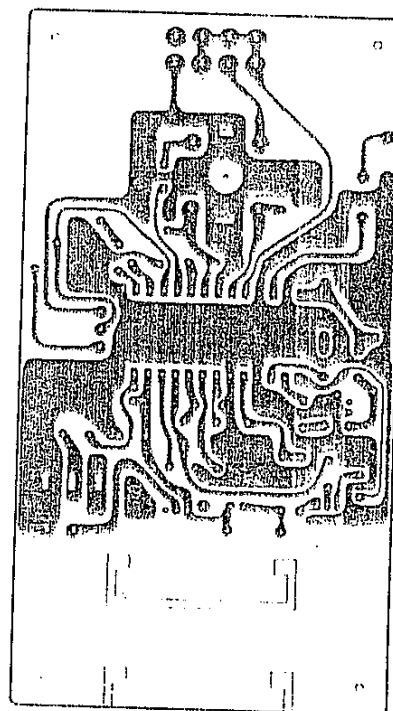

Pattern diagram

Package Outline : Unit : mm

CXA1019M

28 pin SOP (Plastic)

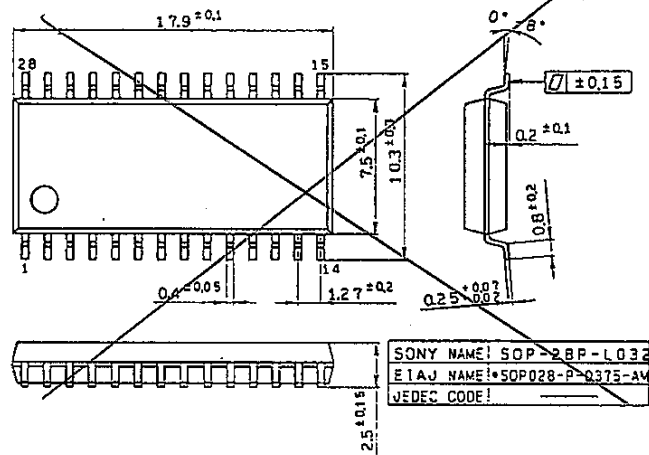
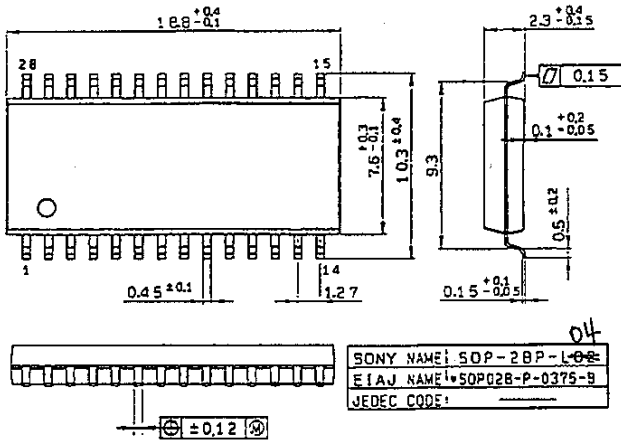

CXA1019P

28 pin DIP (Plastic)

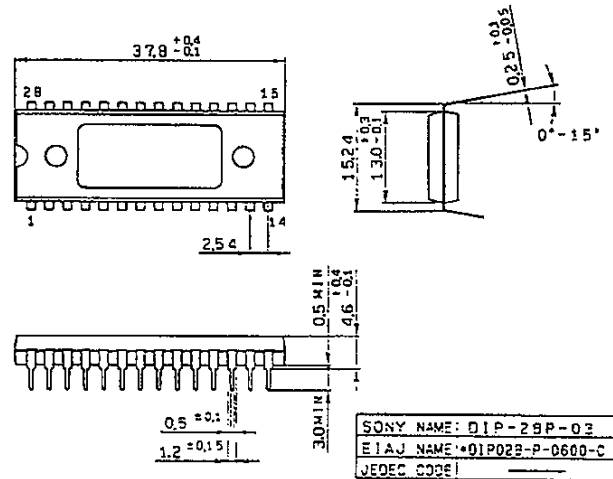
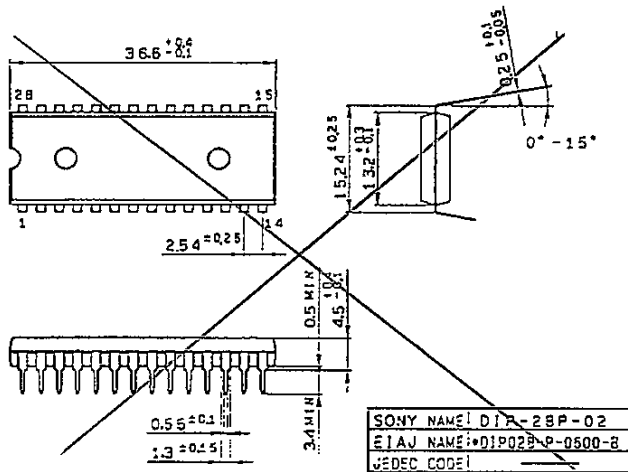

CXA1019S

30 pin SDIP (Plastic)

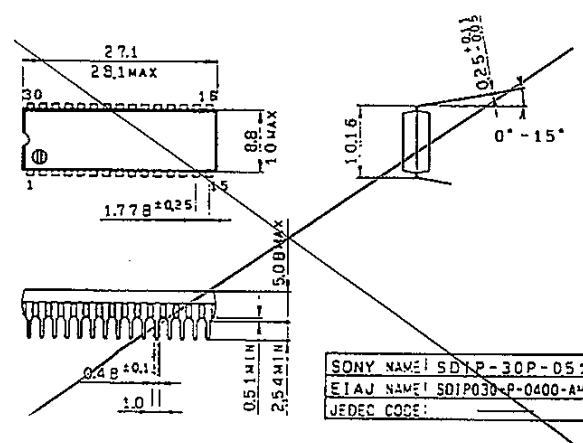
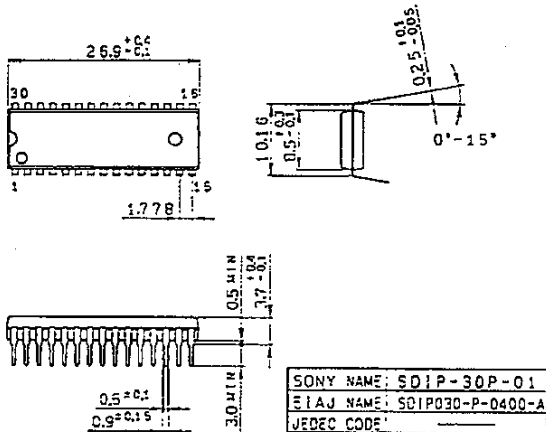

NOTE : PALLADIUM PLATING  
This product uses S-PdPFF (Sony Spec.-Palladium Pre-Plated Lead Frame).

Package Outline Unit: mm

28PIN SOP (PLASTIC)

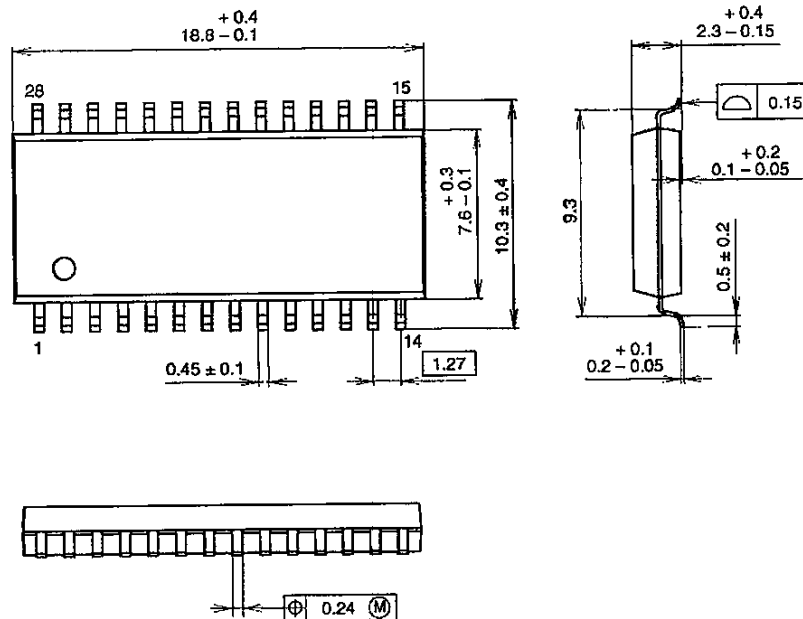

PACKAGE STRUCTURE

SONY CODE	SOP-28P-L04
EIAJ CODE	SOP028-P-0375
JEDEC CODE	_____

PACKAGE MATERIAL	EPOXY RESIN
LEAD TREATMENT	SOLDER PLATING
LEAD MATERIAL	42/COPPER ALLOY
PACKAGE MASS	0.7g

LEAD PLATING SPECIFICATIONS

ITEM	SPEC.
LEAD MATERIAL	COPPER ALLOY
SOLDER COMPOSITION	Sn-Bi Bi:1-4wt%
PLATING THICKNESS	5-18μm