

# HA1406

## AUDIO PREAMPLIFIER

### FEATURES

- Single-in-Line Package  
There is no need to consume a wide space on the print board.
- Prevention of Reverse Mounting  
Pin 2 is cut down to prevent reverse mounting.
- High Open-loop Voltage Gain: 80dB typ.
- High Input Impedance: 200k $\Omega$  typ.
- Low Noise: 0.9 $\mu$ V typ.  
( $R_g=2.4k\Omega$ , converted into input voltage)



### CIRCUIT SCHEMATIC

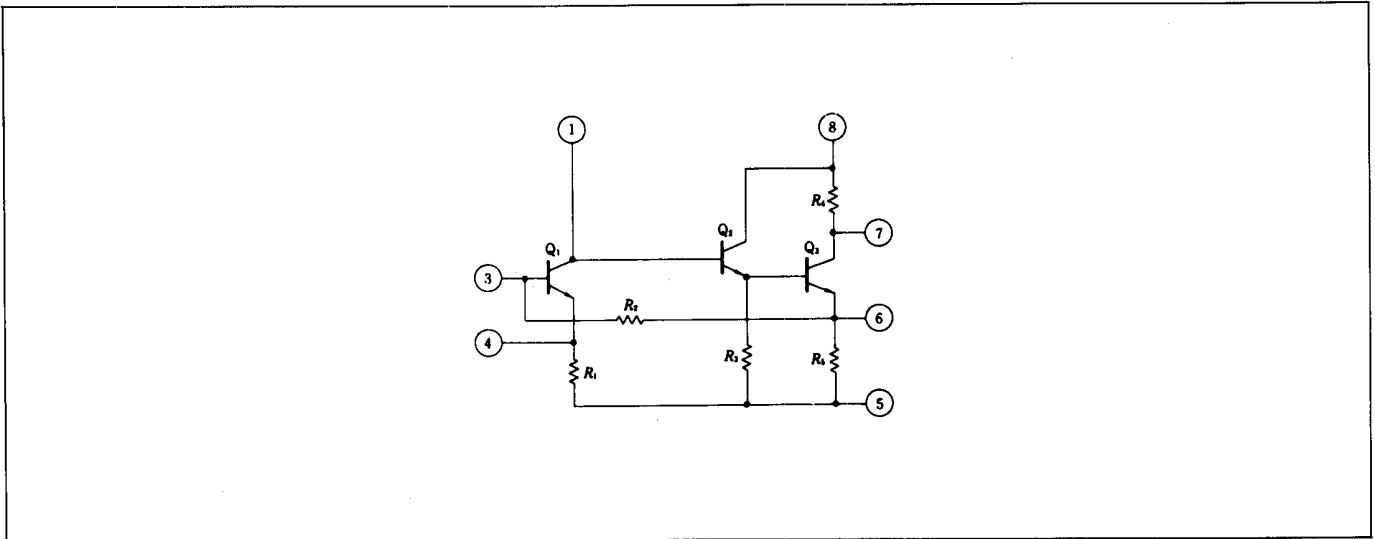

### ABSOLUTE MAXIMUM RATINGS ( $T_a=25^\circ\text{C}$ )

Item	Symbol	Rating	Unit
Supply Voltage	$V_{CC}$	15	V
Power Dissipation	$P_T$	200	mW
Operating Temperature	$T_{opr}$	-30 to +80	$^\circ\text{C}$
Storage Temperature	$T_{stg}$	-55 to +125	$^\circ\text{C}$

### ELECTRICAL CHARACTERISTICS ( $V_{CC}=9\text{V}$ , $f=1\text{kHz}$ , $R_L=5.1k\Omega$ , $T_a=25^\circ\text{C}$ )

Item	Symbol	Test Circuit	Test Condition	min	typ	max	Unit
Quiescent Current	$I_a$	1		0.8	1.3	1.7	mA
Open-loop Voltage Gain	$G_{V(O.L.)}$	1	$V_{out}=-10\text{dBm}$	75	80	—	dB
Voltage Gain	$G_V$	2		—	53.5	—	dB
Output Voltage	$V_{out}$	3	$T.H.D=1\%$	0.7	—	—	V
Total Harmonic Distortion	$T.H.D$	3	$V_{out}=0.3\%$ , $f=1\text{kHz}$	—	0.25	—	%
Input Impedance	$Z_{in}$		$f=1\text{kHz}$	70	—	—	k $\Omega$
Noise Voltage Converted into Input	$V_n^*$	4	$R_g=2.4k\Omega$	—	0.9	2.2	$\mu\text{V}$

\* Value converted into output noise voltage in Test Circuit 4 is 43mV typ and 106mV max.

## TEST CIRCUITS

### 1. $I_Q, G_V(OL)$

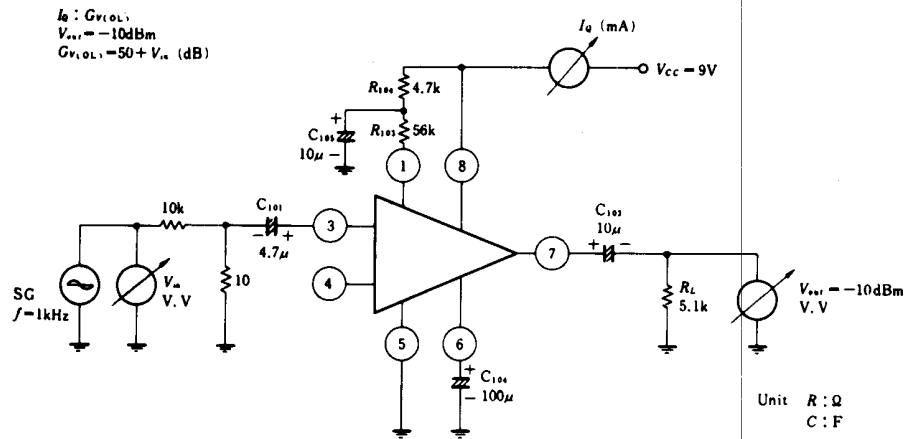

### 2. $G_V$

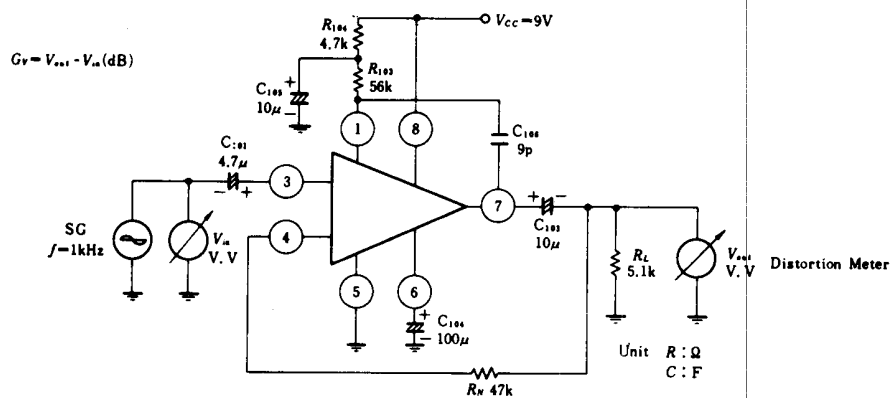

### 3. $V_{out}, T.H.D.$

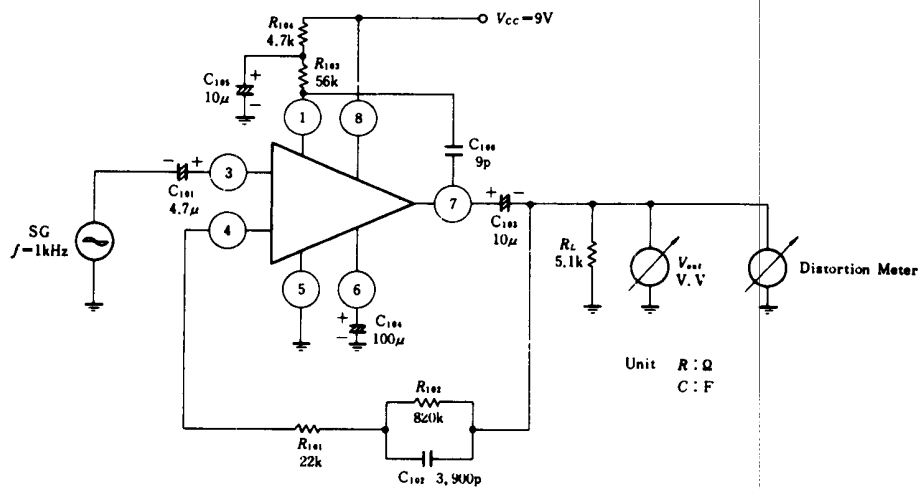

4. Vn

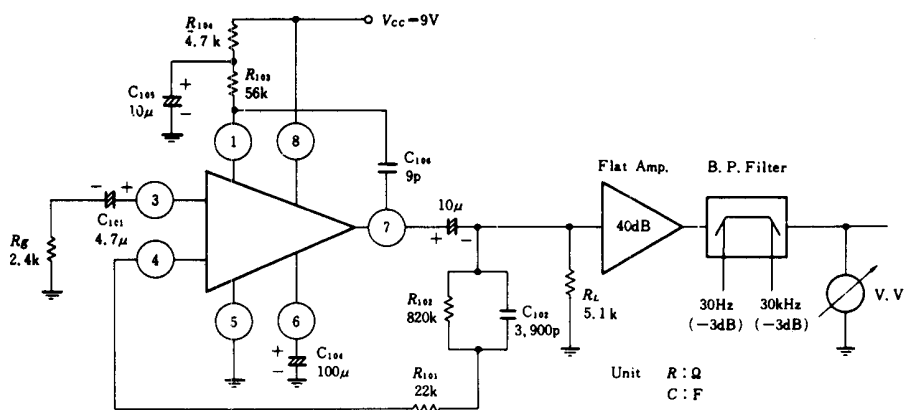

Overall voltage gain of this circuit is set at 93.5dB by adjusting the voltage gain of the flat amp.

QUIESCENT CURRENT VS. AMBIENT TEMPERATURE

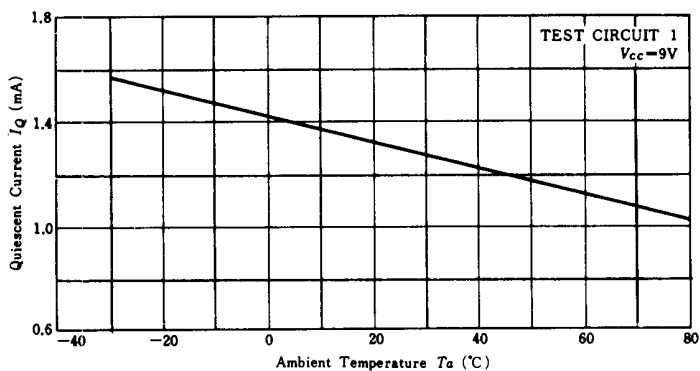

OPEN-LOOP VOLTAGE GAIN VS. SUPPLY VOLTAGE

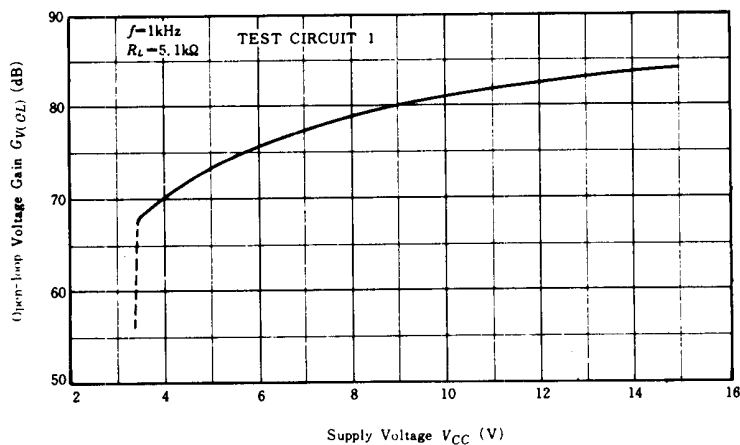

## OUTPUT VOLTAGE VS. SUPPLY VOLTAGE

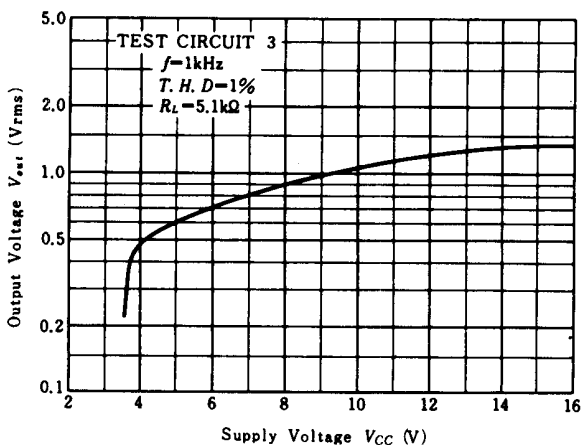

## OUTPUT VOLTAGE VS. AMBIENT TEMPERATURE

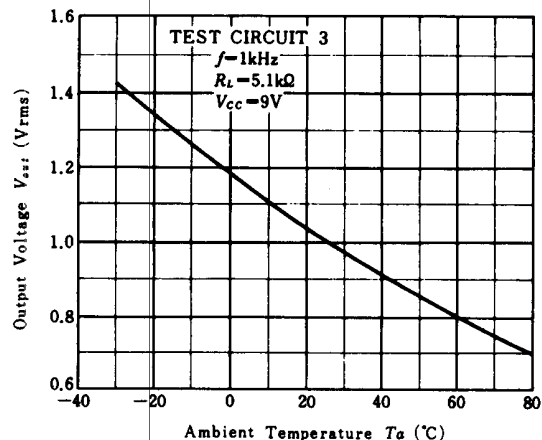

## VOLTAGE GAIN VS. AMBIENT TEMPERATURE

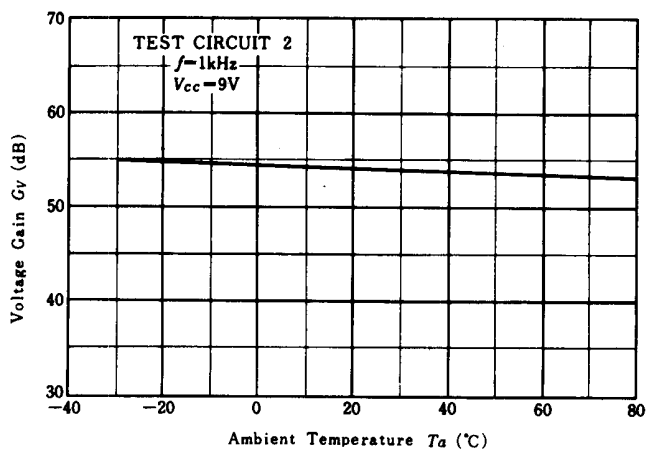

## OUTPUT NOISE VOLTAGE VS. SIGNAL SOURCE RESISTANCE

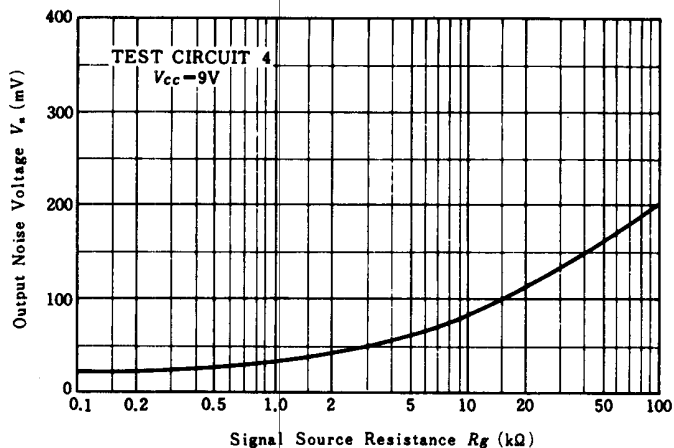

## APPLICATION CIRCUIT EXAMPLE 1 (NAB: 9.5 cm/sec, $G_V = 53.5$ dB, $f = 1$ kHz)

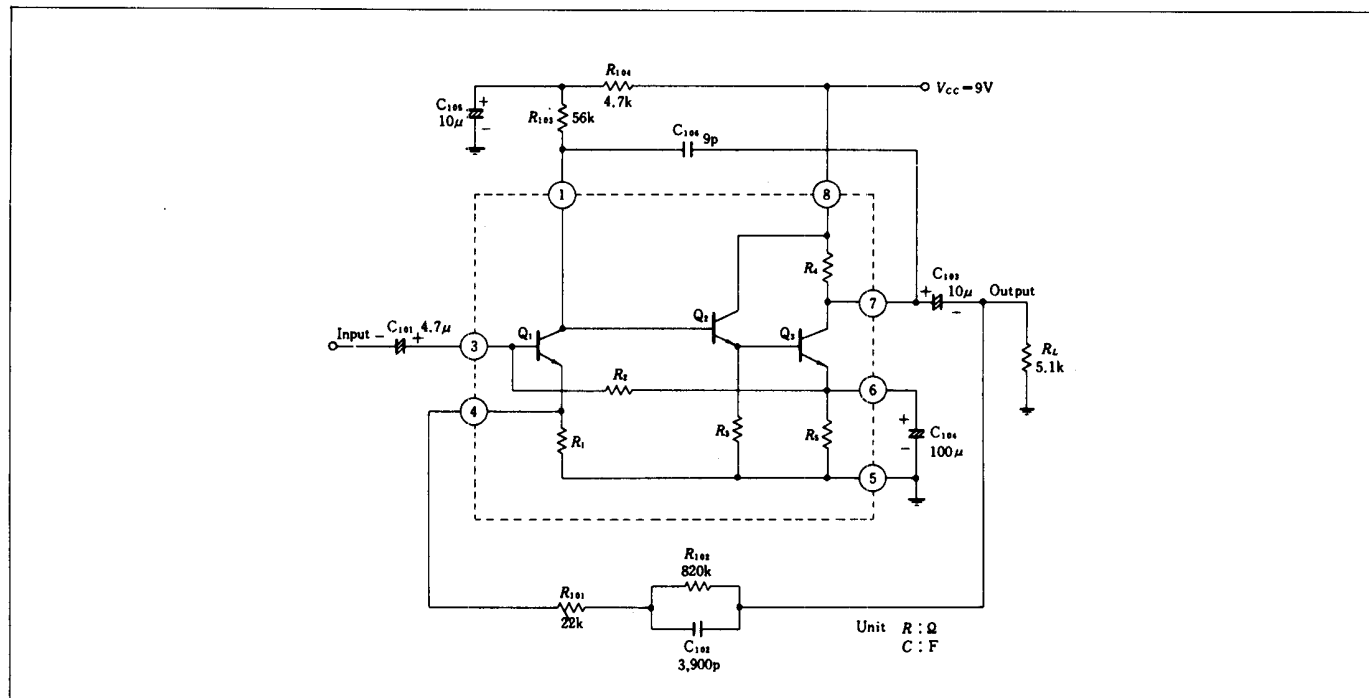

### VOLTAGE GAIN VS. FREQUENCY

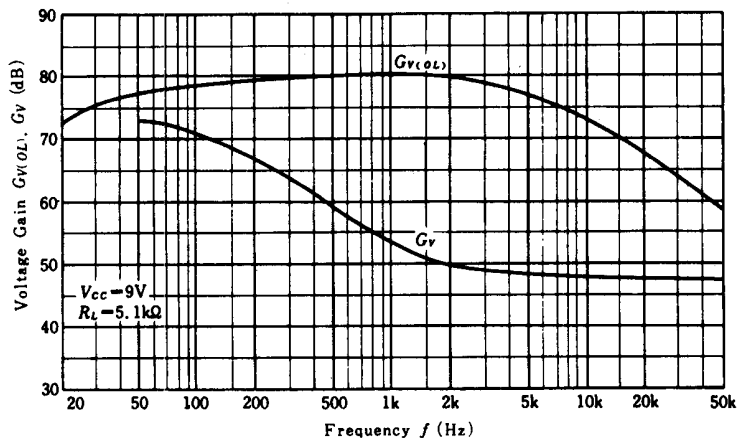

### OUTPUT VOLTAGE VS. INPUT VOLTAGE

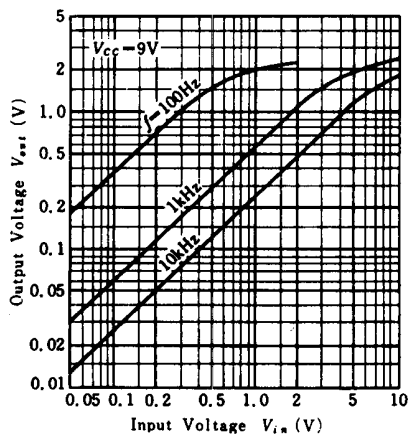

### TOTAL HARMONIC DISTORTION VS. OUTPUT VOLTAGE

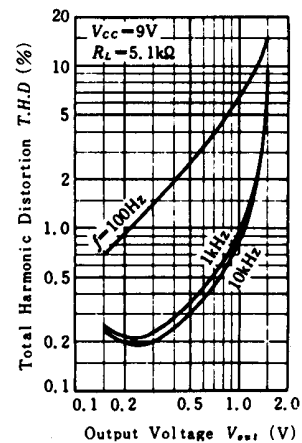

## APPLICATION CIRCUIT EXAMPLE 2 (NAB: 9.5cm/sec, $G_V=44\text{dB}$ , $f=1\text{kHz}$ )

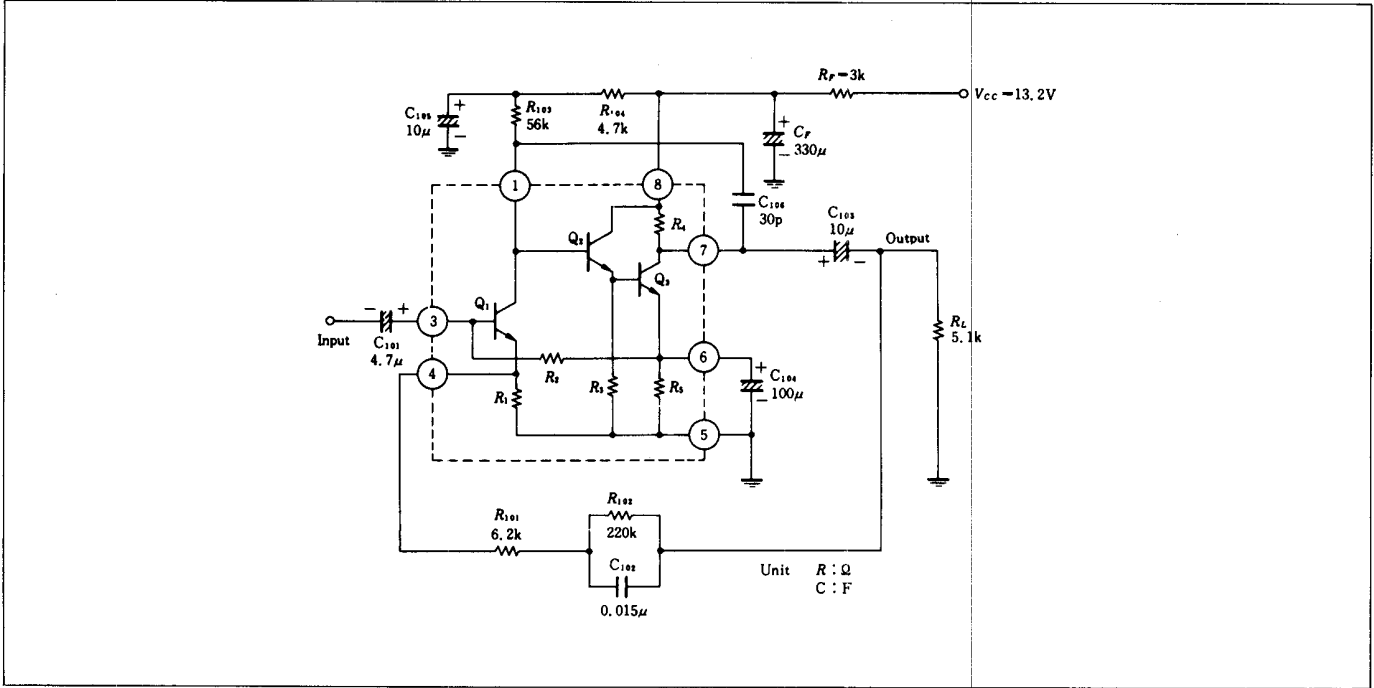

### VOLTAGE GAIN VS. FREQUENCY

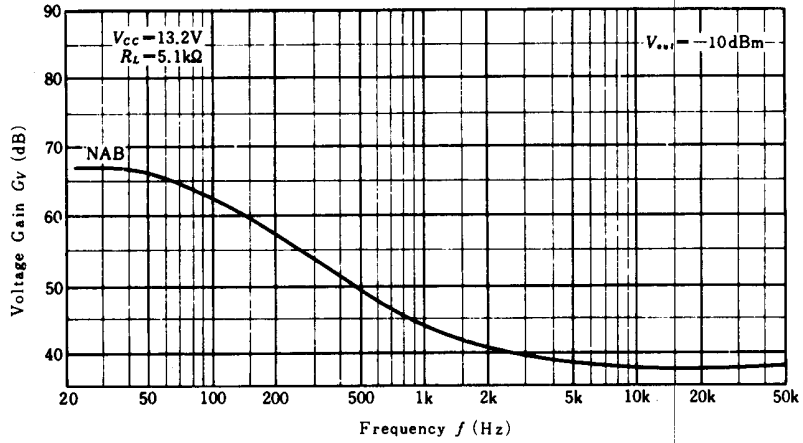

### OUTPUT VOLTAGE VS. INPUT VOLTAGE

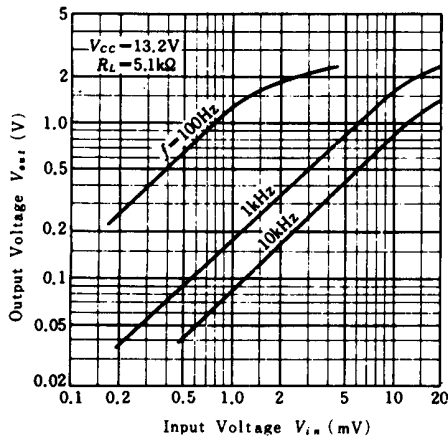

### TOTAL HARMONIC DISTORTION VS. OUTPUT VOLTAGE

