

AN7310N

Dual Pre-Amplifier for Car Radio

■ Description

The AN7310N is a monolithic integrated circuit designed for dual pre-amplifier suitable for car stereo, portable stereo and portable cassette tape recorder. Stabilized characteristics can be obtained for high gain, low distortion, low noise and high output voltage, etc owing to the fact that 2 channels are built-in one chip.

■ Features

- High gain, low distortion and low noise
- Power ON/OFF noise suppression
- Easy for designing due to single-in-line package
- Good channel separation

■ Pin

Pin No.	Pin Name
1	Input Ch. 1
2	N.F.B. Ch. 1
3	Output Ch. 1
4	Ripple Filter
5	GND
6	Vcc
7	Output Ch. 2
8	N.F.B. Ch. 2
9	Input Ch. 2

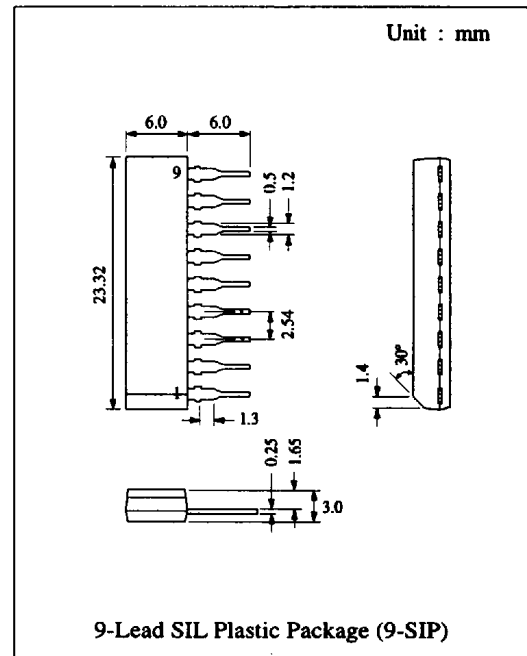

■ Block Diagram

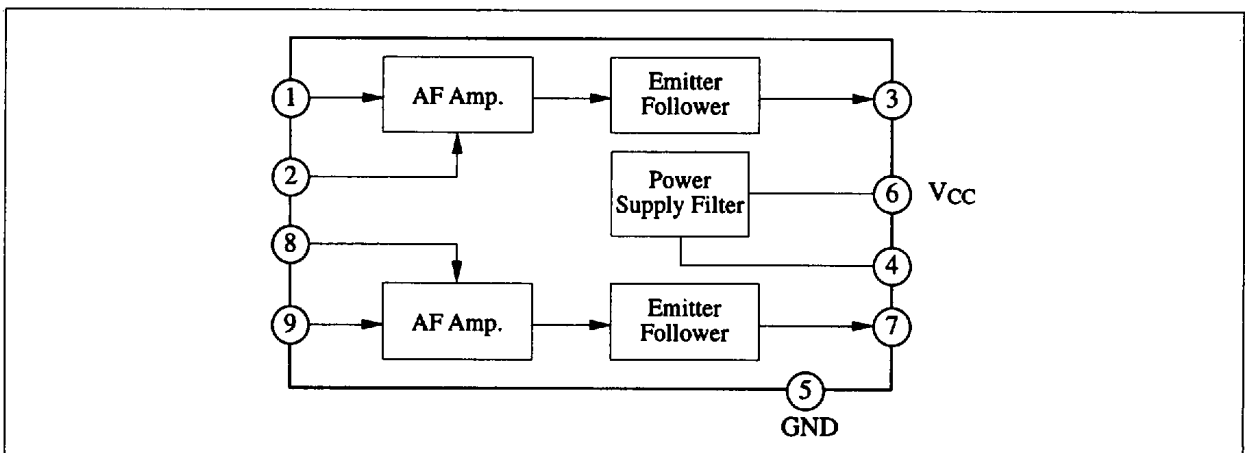

■ Absolute Maximum Ratings (Ta=25°C)

Item	Symbol	Rating	Unit
Supply Voltage	V _{CC}	16	V
Supply Current	I _{CC}	15	mA
Power Dissipation (Ta=75°C)	P _D	240	mW
Operating Ambient Temperature	Topr	-30 ~ +75	°C
Storage Temperature	Tstg	-55 ~ +125	°C

Operating Supply Voltage Range: V_{CC} = 4.0V ~ 16.0V

■ Electrical Characteristics (V_{CC}=8V, f=1kHz, R_L=10kΩ Ta=25°C)

Item	Symbol	Test Circuit	Condition	min.	typ.	max.	Unit
Quiescent Current	I _{CC}	1	V _{in} = 0mV		4	8	mA
Open Loop Voltage Gain	G _{VO}	1	V _{in} = 20mV	80	90		dB
Output Voltage	V _O	2	THD = 1%	1.2	2.2		V
Total Harmonic Distortion	THD	2	V _O = 0.3V		0.03	0.1	%
Noise Voltage Referred to Input	V _{ni} *	2	R _g = 2.2kΩ		1.2	2	μV
Input Impedance	Z _{in}				100		kΩ
Crosstalk	CT		R _g = 2.2kΩ, f = 10kHz		-74		dB

* Measure with 15Hz ~ 30kHz (-3dB) filter

Test Circuit 1 (I_{tot}, G_{VO})

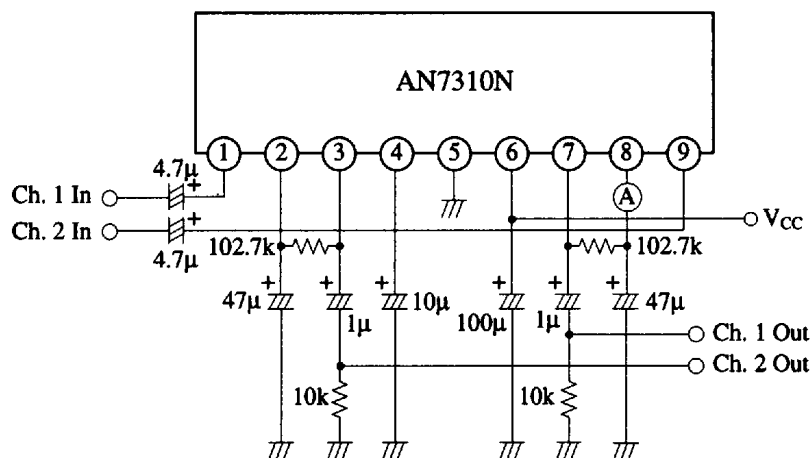

Test Circuit 2 (V_o , THD, V_{ni})

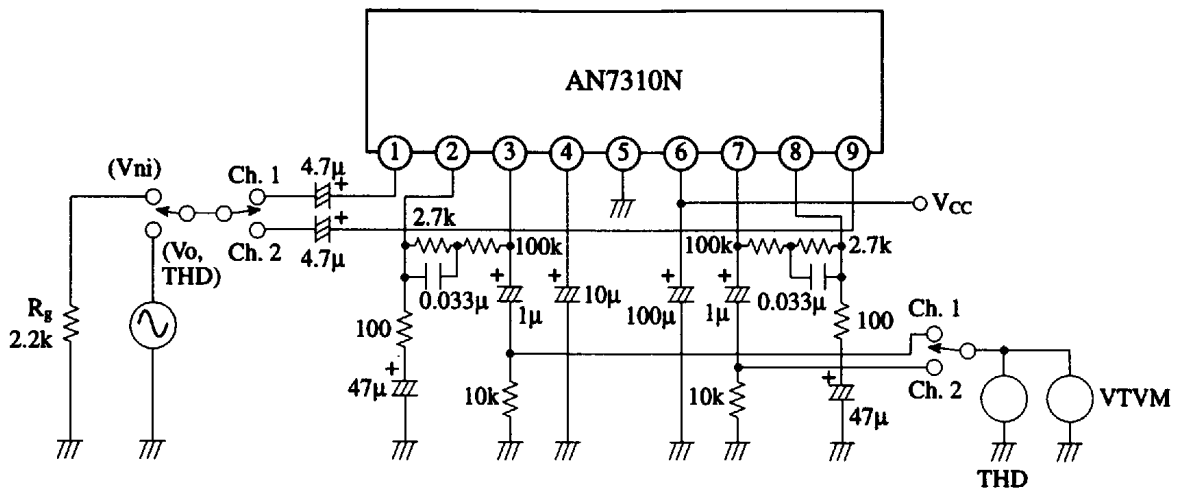

Note 1) THD is measured by equipment with 400Hz low pass filter
 Note 2) V_{ni} is measured by equipment with 15Hz ~ 30kHz band pass filter

Application Circuit

1. For high voltage type

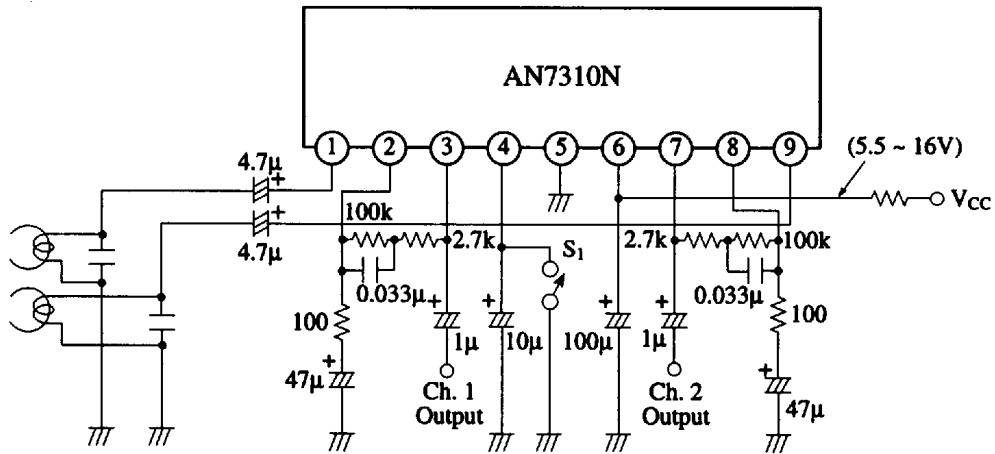

2. For low voltage type

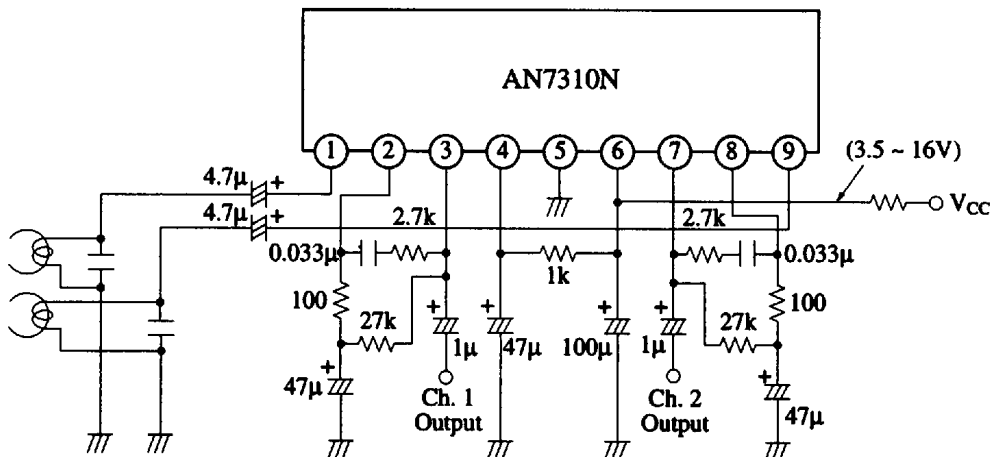

■ Characteristics Curve

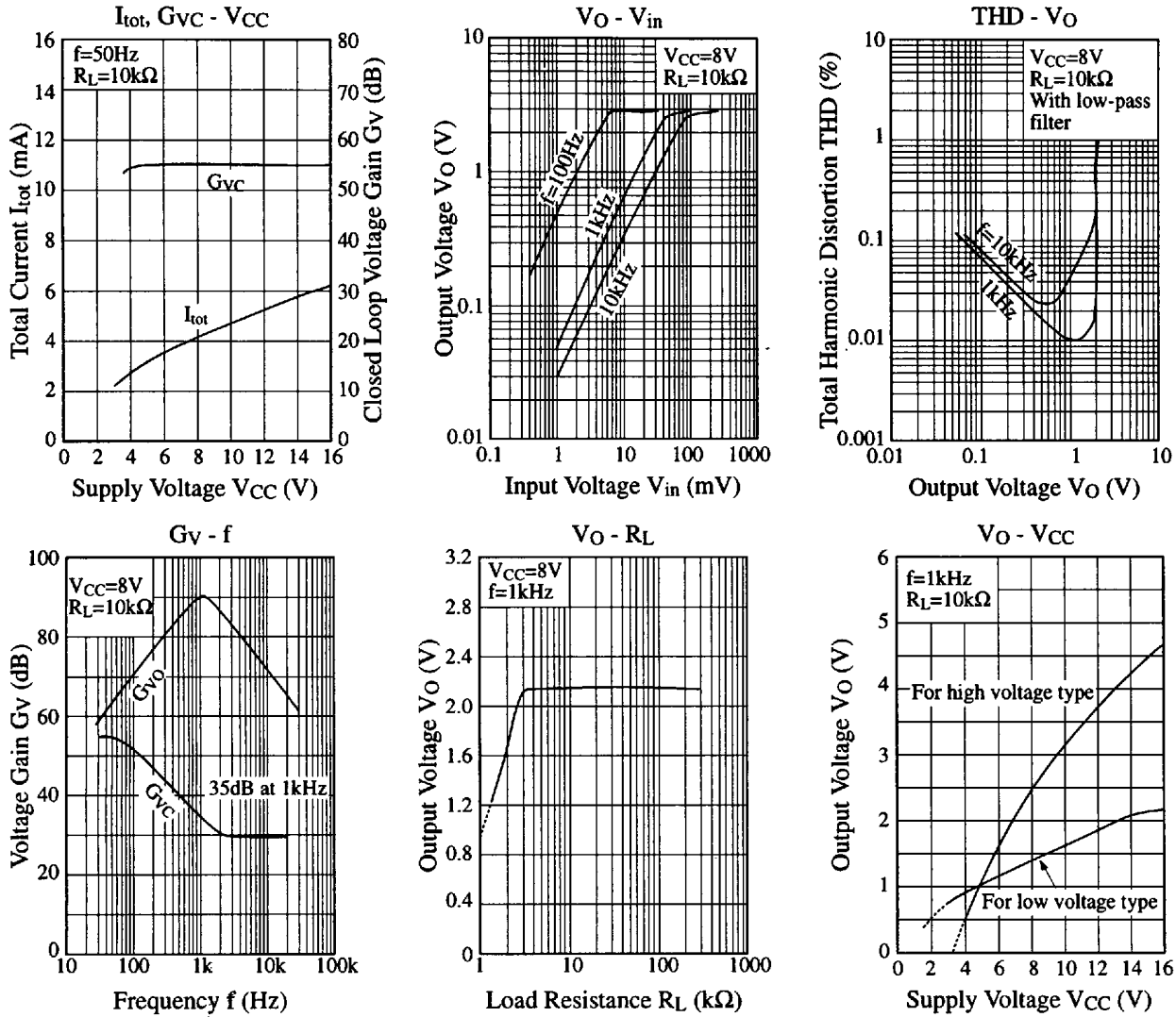

■ Printed Circuit Board Layout (Scale: 1:1)

