

**Features**

- 4 channels of DC motor BTL driver
- 1 channels forward/reverse control DC motor driver
- Built-in suspension function.
- Built-in 2 Linear Regulator
- Built-in 1-Channel operational amplifier.
- Built-in thermal shutdown circuit.
- Operating voltage: 4.5V~13.2V

**Description**

The AT5669 is a 5-channel BTL driver IC. Two of them can drive DC motors and two can drive coils, such as the focus and tracking actuators of a CD-ROM/DVD-ROM/DVD-Player system. It also built-in one channel bi-direction DC motor driver for Tray. Using the built-in linear regulator, it can be save the PCB space. It also includes 1 operational amplifier.

**Applications**

CD-ROM/DVD-ROM/CD-RW drives  
DVD player.

**Block Diagram**

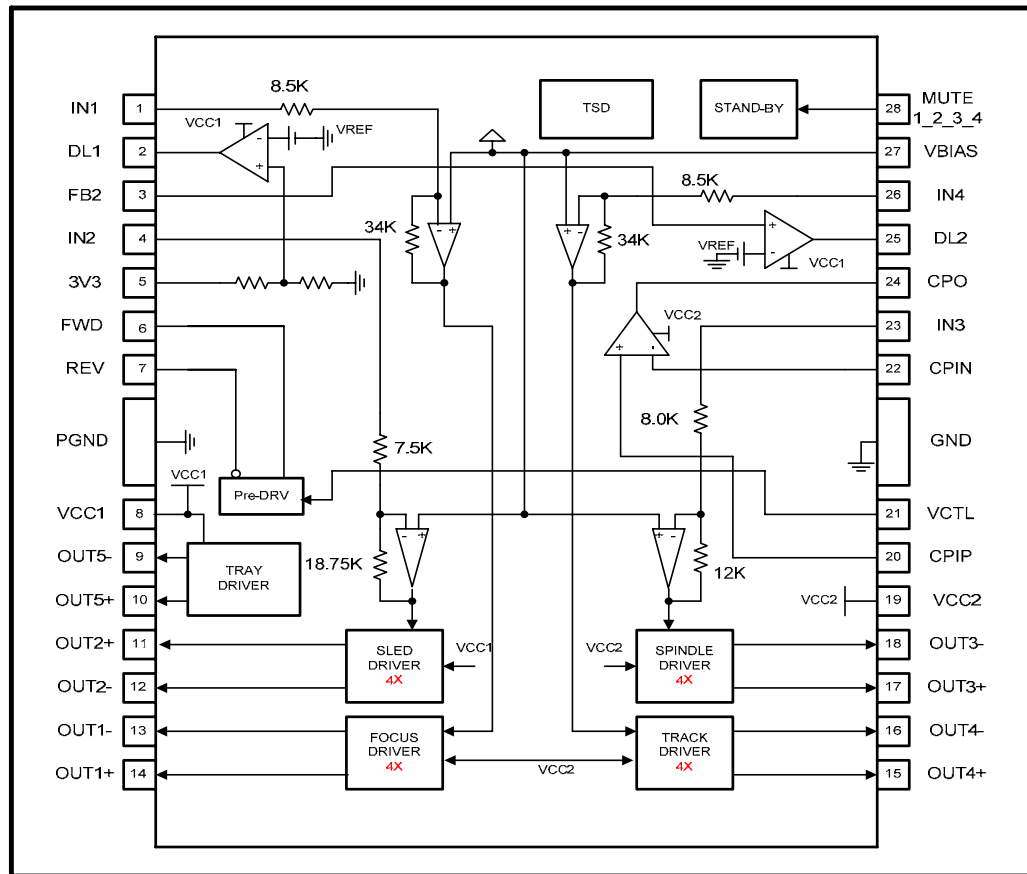

**Aimtron reserves the right without notice to change this circuitry and specifications.**

**Pin Descriptions**

Pin No.	Pin name	Function
1	IN1	CH1(Focus coil) input
2	DL1	Linear Regulator 3V3 driver output
3	FB2	Linear Regulator 2 feedback input
4	IN2	CH2(Sled driver) input
5	3V3	Linear Regulator 3V3 input
6	FWD	CH5 forward input
7	REV	CH5 reverse input
8	VCC1	Power Supply 1
9	OUT5-	CH5(Tray driver) output(-)
10	OUT5+	CH5(Tray driver) output(+)
11	OUT2+	CH2(Sled driver) output (+)
12	OUT2-	CH2(Sled driver) output (-)
13	OUT1-	CH1(Focus coil) output (-)
14	OUT1+	CH1(Focus coil) output (+)
15	OUT4+	CH4(Tracking coil) output (+)
16	OUT4-	CH4(Tracking coil) output (-)
17	OUT3+	CH3(Spindle) output (+)
18	OUT3-	CH3(Spindle) output (-)
19	VCC2	Power Supply 2
20	CPIP	OP positive input
21	VCTL	CH5 Speed control input
22	CPIN	OP negative input
23	IN3	CH3(Spindle) input
24	CPO	OP Output
25	DL2	Adjustable Linear Regulator driver output
26	IN4	CH4 (Tracking driver) input
27	VBIAS	VREF input pin
28	MUTE_1_2_3_4	Mute control for CH1,CH2,CH3,CH4

**Notes:** The indicated polarities for the output pins are under the condition that all inputs are (+).

The power supplies for the driver output are Vcc1 for the loader, Vcc2 for focus and tracking drivers, and Vcc for pre-block and sled driver. Therefore, make sure  $V_{cc1} \geq V_{cc2}$ .

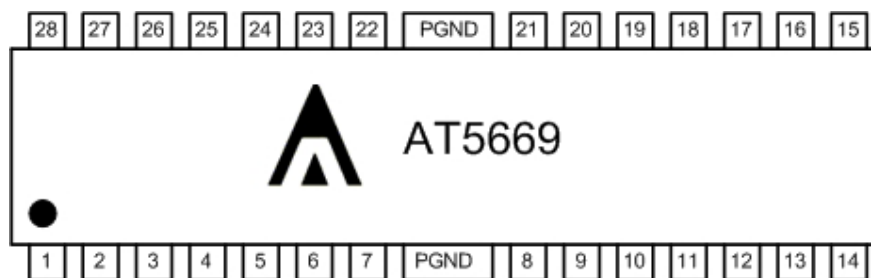
**Pin Out**

**Ordering Information**

Part number	Package	Marking
AT5669H	28-pin HSOP	AT5669H
AT5669H_PBF	28-pin HSOP, PB-Free	AT5669H, Date Code with one bottom line

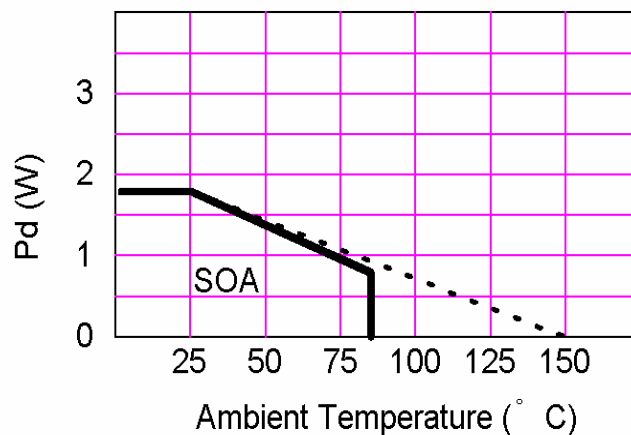
**Power Dissipation (Ta = 25°C)**

 Condition: mount on 50x50 mm<sup>2</sup> t=1.0mm paper phenol PCB

**Absolute maximum ratings (Ta = 25°C)**

Parameter	Symbol	Limits	unit
Power supply voltage	VCC1,2	13.5	V
Power dissipation	P <sub>d</sub>	1.7	W
Operating temperature	T <sub>opr</sub>	-30~+80	°C
Storage temperature	T <sub>stg</sub>	-55~+150	°C

NOTE:\*

1. Power dissipation reduces 13.6mW / °C for using above Ta=25°C
2. Do not exceed Pd and SOA.

**Recommended operating conditions (Ta = 25°C)**

Parameter	Symbol	Limits	unit
Power supply voltage	VCC1	4.0~13.2	V
	VCC2	4.0~Vcc1	V

**Electrical characteristics**

(unless otherwise noted, Ta = 25°C, VCC1 = 5V, VCC2 = 5V, VBIAS = 2.5V, RL1 = RL4 = 10Ω, RL2 = 10Ω, RL3 = 10Ω)

Parameter	Symbol	Min.	Typ.	Max.	Unit	Conditions
Quiescent current	I <sub>QC</sub>	-	20	35	mA	No Load, FWD=REV=Low
Mute quiescent current	I <sub>QSB</sub>	-	-	8	mA	CH5 ,COMP. Active LD1,LD2 floating
Bias input current	I <sub>Bias</sub>	-	-	1	μA	
Mute ON voltage	V <sub>SBON</sub>	0	-	0.5	V	
Mute OFF voltage	V <sub>SBOFF</sub>	1.2	-	-	V	
<b>&lt;Track driver&gt;</b>						
Output voltage offset	V <sub>OFFSL</sub>	-100	0	100	mV	
Maximum output voltage	V <sub>O4MAX</sub>	3.6	4.0	-	V	V <sub>IN</sub> = V <sub>BIAS</sub> ±1.5V
Closed loop gain	G <sub>VSL</sub>	-	24.0	-	dB	V <sub>IN</sub> = V <sub>BIAS</sub> ±0.2V
<b>&lt;Focus driver&gt;</b>						
Output voltage offset	V <sub>OFFSL</sub>	-100	0	100	mV	
Maximum output voltage	V <sub>O1MAX</sub>	3.6	4.0	-	V	V <sub>IN</sub> = V <sub>BIAS</sub> ±1.5V
Closed loop gain	G <sub>VSL</sub>	-	24.0	-	dB	V <sub>IN</sub> = V <sub>BIAS</sub> ±0.2V
<b>&lt;Sled motor driver&gt;</b>						
Output voltage offset	V <sub>OFFSL</sub>	-100	0	100	mV	
Maximum output voltage	V <sub>O2max2</sub>	3.6	4.0	-	V	V <sub>IN</sub> = V <sub>BIAS</sub> ±1.5V
Closed loop gain	G <sub>VSL</sub>	18.0	20.0	22.0	dB	V <sub>IN</sub> = V <sub>BIAS</sub> ±0.2V
<b>&lt;Spindle motor driver&gt;</b>						
Output voltage offset	V <sub>OFFLD</sub>	-100	0	100	mV	
Maximum output voltage	V <sub>O3max2</sub>	3.6	4.0	-	V	V <sub>IN</sub> = V <sub>BIAS</sub> ±1.5V
Closed loop gain	G <sub>VLD</sub>	13.5	15.5	17.5	dB	V <sub>IN</sub> = V <sub>BIAS</sub> ±0.2V
Gain error	ΔG <sub>VLD</sub>	0	1	2	dB	V <sub>IN</sub> = V <sub>BIAS</sub> ±0.2V
<b>&lt;Tray motor driver&gt;</b>						
Maximum output voltage	V <sub>O5max1</sub>	-	3.95	-	V	RL5=30Ω, RVCTL=0Ω,
		-	4.05	-	V	RL5=45Ω, RVCTL=0Ω,
Output voltage offset	V <sub>OFFTR</sub>	-100	0	100	mV	
Input high level voltage	V <sub>IH</sub>	1.2	-	-	V	
Input low level voltage	V <sub>IL</sub>	-	-	0.5	V	
High level input current	I <sub>IH</sub>	-	25	50	μA	FWD=REV=2.5V
<b>&lt;Comparator&gt;</b>						
Input Offset	V <sub>Offset</sub>	-	-	±15	mV	
Input Dynamic Range		0	-	VCC1-1.5V	V	
Output Dynamic Range	V <sub>OH</sub>	-	-	VCC1-1.0V	V	I <sub>O</sub> = -1mA



圓創科技股份有限公司

**AT5669**

**5-Channel Motor Driver for DVD/VCD  
with 2 Linear Regulator and 1 OPAMP**

	V <sub>OL</sub>	0.25	-	0.40	V	I <sub>O</sub> =4mA
Voltage Gain	A <sub>v</sub>	-	80	-	dB	DC
<b>&lt;Linear Regulator 1&gt;</b>						
3V3 Threshold Voltage	V <sub>T1</sub>	3.234	3.300	3.366	V	
3V3 Input Bias Current	I <sub>T1</sub>	1.0	-	3.0	mA	3V3=3.3V
Output sink current of DL1	I <sub>DL1</sub>	10	-	30	mA	
<b>&lt;Linear Regulator 2&gt;</b>						
FB2 Threshold Voltage	V <sub>T2</sub>	1.225	1.25	1.275	V	
FB2 Input Bias Current	I <sub>T2</sub>	-	-	1	μA	FB2=1.8V
Output sink current of DL2	I <sub>DL2</sub>	10	-	30	mA	

7F, NO.9, Park Avenue II, Science-Based Industrial Park, Hsinchu 300, Taiwan, R.O.C.

Tel: 886-3-563-0878

Fax: 886-3-563-0879

WWW: <http://www.aimtron.com.tw>

8/22/2006 REV:1.1

Email: [service@aimtron.com.tw](mailto:service@aimtron.com.tw)

**Tray Motor Driver**

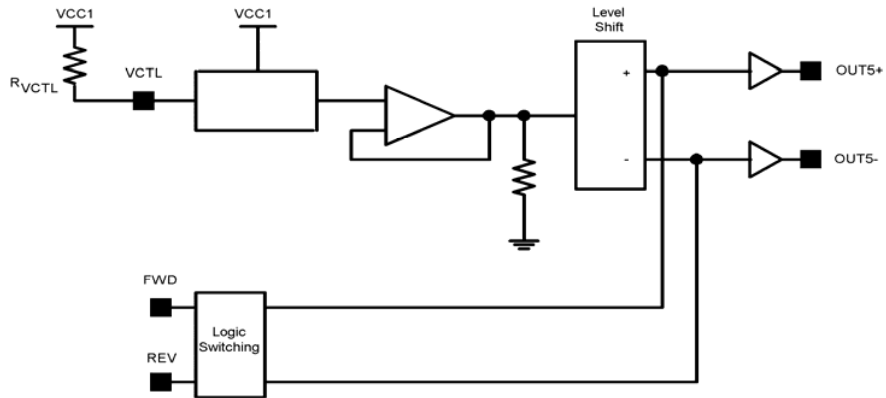

**Fig1.**

Input		Output		
FWD	REV	OUT5+	OUT5-	Status
High	High	Low	Low	Break
High	Low	High	Low	Forward
Low	High	Low	High	Reverse
Low	Low	Open	Open	Standby

**Tray Motor Speed Control**

The amplitude of the output voltage is controlled by VCTL(pin21). If you want to control differential output voltage of the tray, insert external resistor R<sub>VCTL</sub> as shown in figure 1.

**Test Circuit**

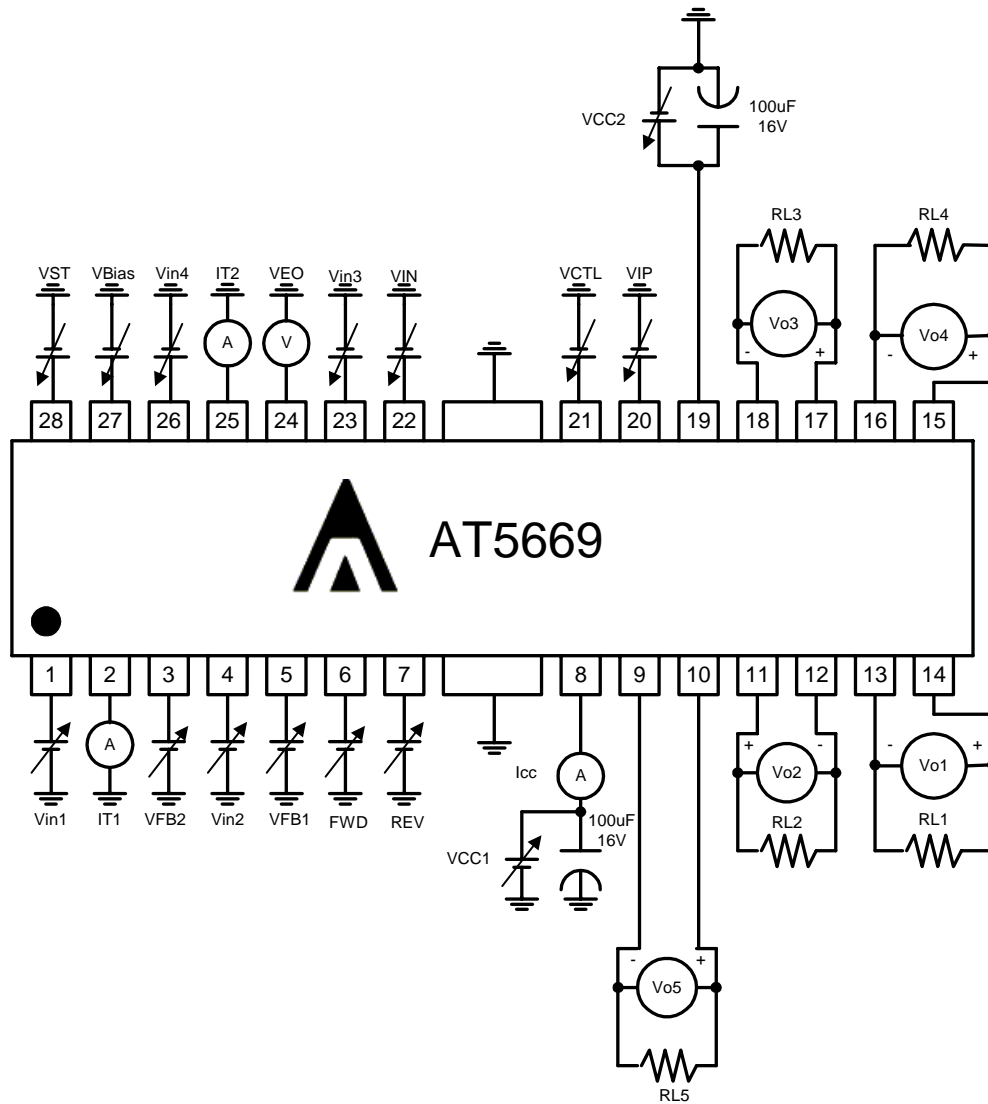

**Typical Curve**

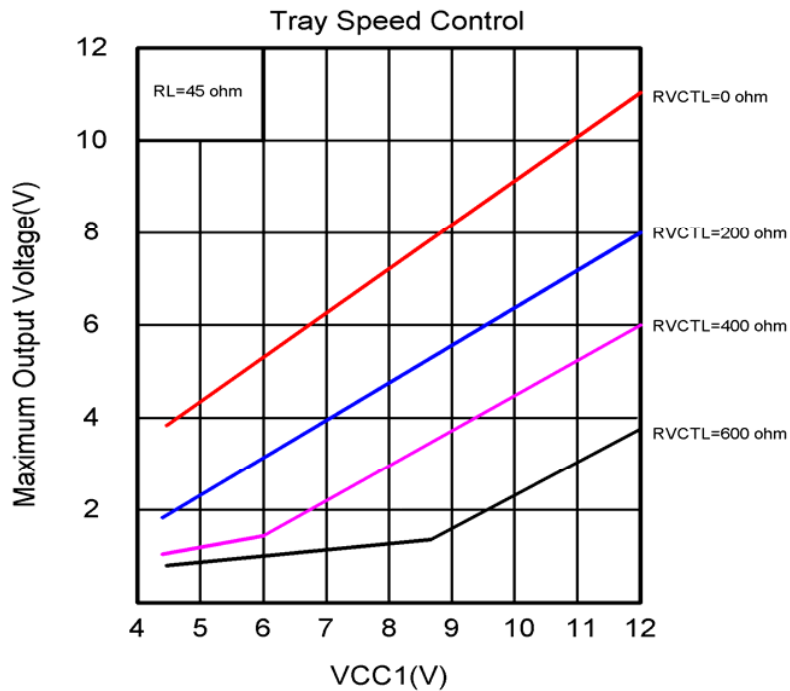
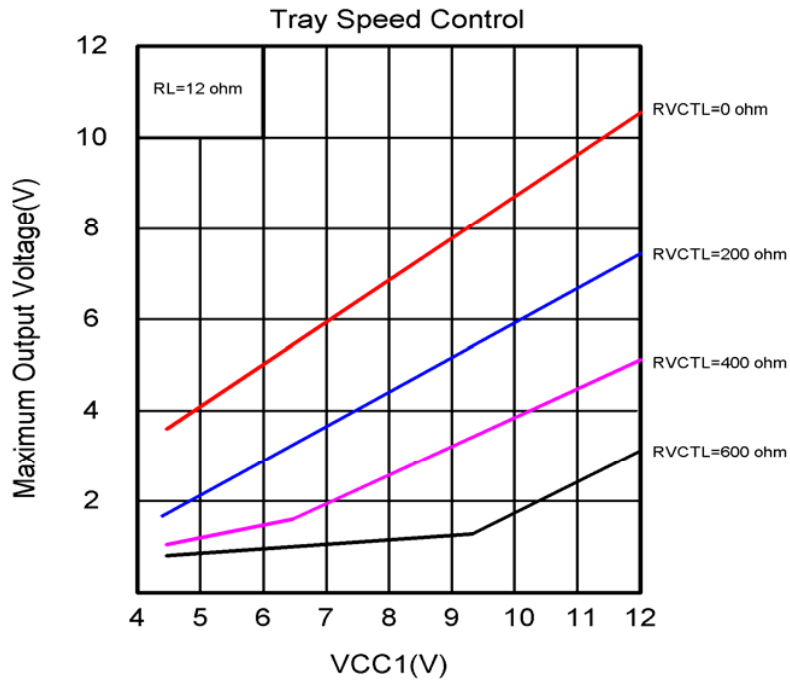



**Application circuit**

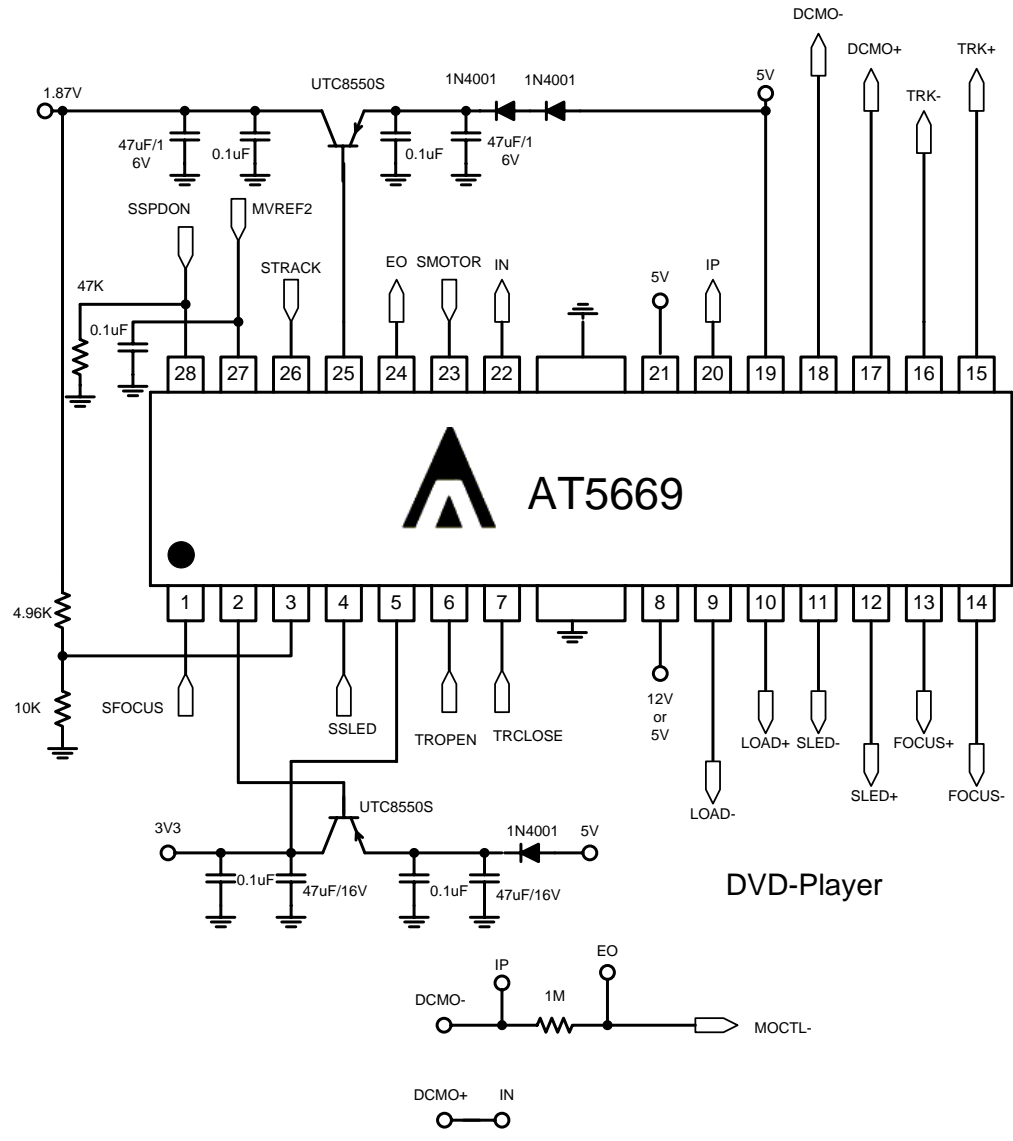

**Package Outlines (units:mm): HSOP-28**

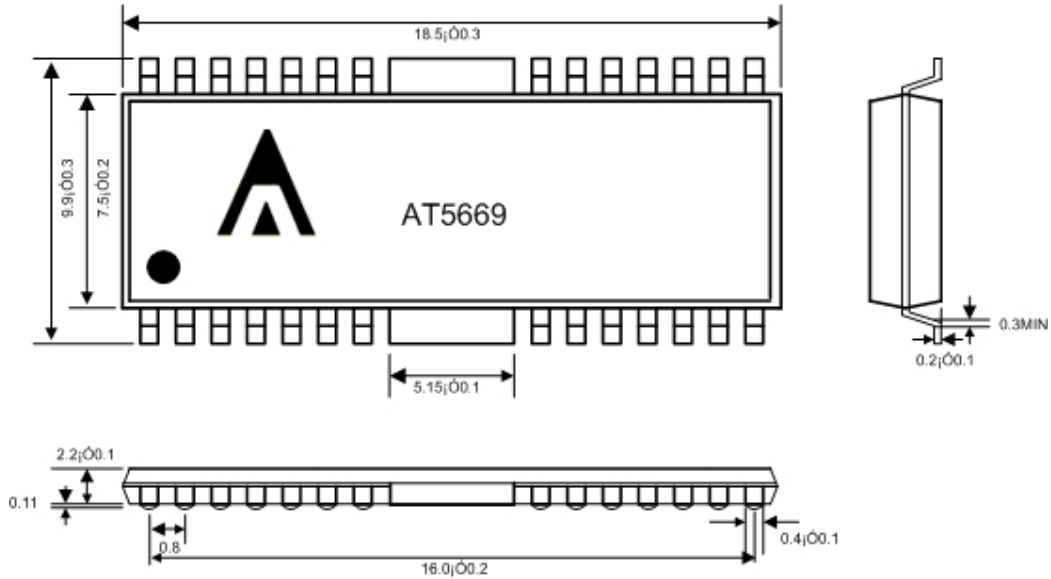

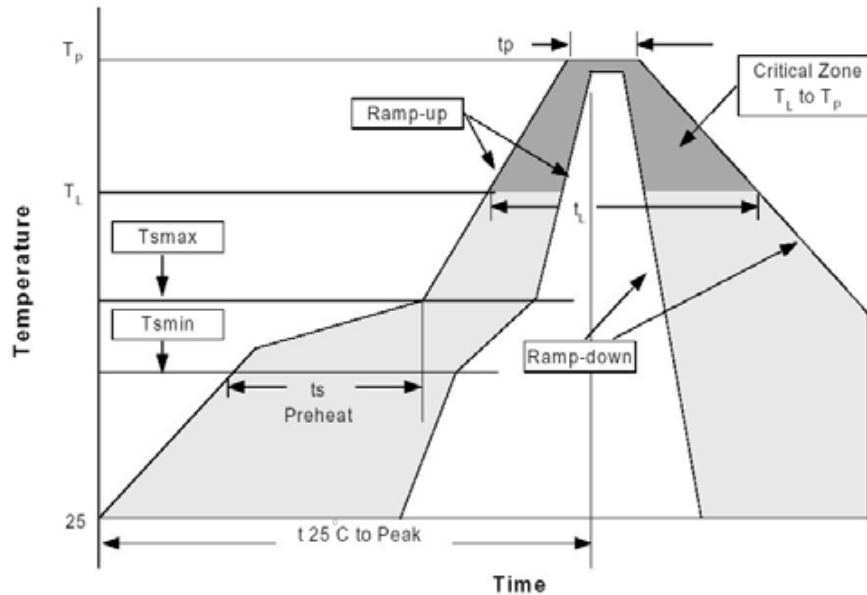
**Reflow Profiles**

Profile Feature	Sn-Pb Eutectic Assembly		Pb-Free Assembly	
	Large Body Pkg. thickness ≥2.5mm or Pkg. volume ≥350mm <sup>3</sup>	Small Body Pkg. thickness <2.5mm or Pkg. volume <350mm <sup>3</sup>	Large Body Pkg. thickness ≥2.5mm or Pkg. volume ≥350mm <sup>3</sup>	Small Body Pkg. thickness ≥2.5mm or Pkg. volume ≥350mm <sup>3</sup>
Average ramp-up rate (T <sub>L</sub> to T <sub>P</sub> )	3°C/second max.		3°C/second max.	
Preheat				
-Temperature Min(T <sub>smin</sub> )	100°C		150°C	
-Temperature Max (T <sub>smax</sub> )	150°C		200°C	
-Time (min to max)(t <sub>s</sub> )	60-120 seconds		60-180 seconds	
T <sub>smax</sub> to T <sub>L</sub>			3°C/second max.	
-Ramp-up Rate				
Time maintained above:				
-Temperature (T <sub>L</sub> )	183°C		217°C	
-Time (t <sub>L</sub> )	60-150 seconds		60-150 seconds	
Peak Temperature(T <sub>P</sub> )	225+0/-5°C	240+0/-5°C	245+0/-5°C	250+0/-5°C
Time within 5°C of actual Peak Temperature (t <sub>p</sub> )	10-30 seconds	10-30 seconds	10-30 seconds	20-40 seconds
Ramp-down Rate	6°C/second max.		3°C/second max.	
Time 25°C to Peak Temperature	6 minutes max.		8 minutes max.	

\*All temperatures refer to topside of the package, measured on the package body surface.