

# Ground isolation amplifier

## BA3121 / BA3121F / BA3121N

The BA3121, BA3121F and BA3121N are ground isolation amplifiers developed for use in car audio applications. These ICs efficiently eliminate problems caused by wiring resistance, and remove noise generated by the electrical devices used in automobiles. The capacitance values of the external capacitors required for the ICs are small to allow compact and reliable set design.

### ●Applications

Car audio systems

### ●Features

- 1) Large capacitors not required
- 2) High common-mode rejection ratio (57dB typ. at  $f = 1\text{kHz}$ ).
- 3) Low noise ( $V_{NO} = 3.5\mu\text{V}_{rms}$  Typ.).
- 4) Low distortion (THD = 0.002% Typ.).
- 5) Two channels.

### ●Absolute maximum ratings ( $T_a = 25^\circ\text{C}$ )

Parameter	Symbol	Limits	Unit
Power supply voltage	$V_{CC}$	18	V
Power dissipation	Pd	800 (BA3121)*	mW
		450 (BA3121F)*	
		900 (BA3121N)*	
Operating temperature	$T_{opr}$	$-30 \sim +85$	$^\circ\text{C}$
Storage temperature	$T_{stg}$	$-55 \sim +125$	$^\circ\text{C}$

\* Reduced by 8.0mW (BA3121), 4.5mW (BA3121F), and 9.0mW (BA3121N) for each increase in  $T_a$  of  $1^\circ\text{C}$  over  $25^\circ\text{C}$ .

### ●Recommended operating conditions ( $T_a = 25^\circ\text{C}$ )

Parameter	Symbol	Min.	Typ.	Max.	Unit
Power supply voltage	$V_{CC}$	4	12	18	V

● Block diagrams

BA3121 / BA3121F

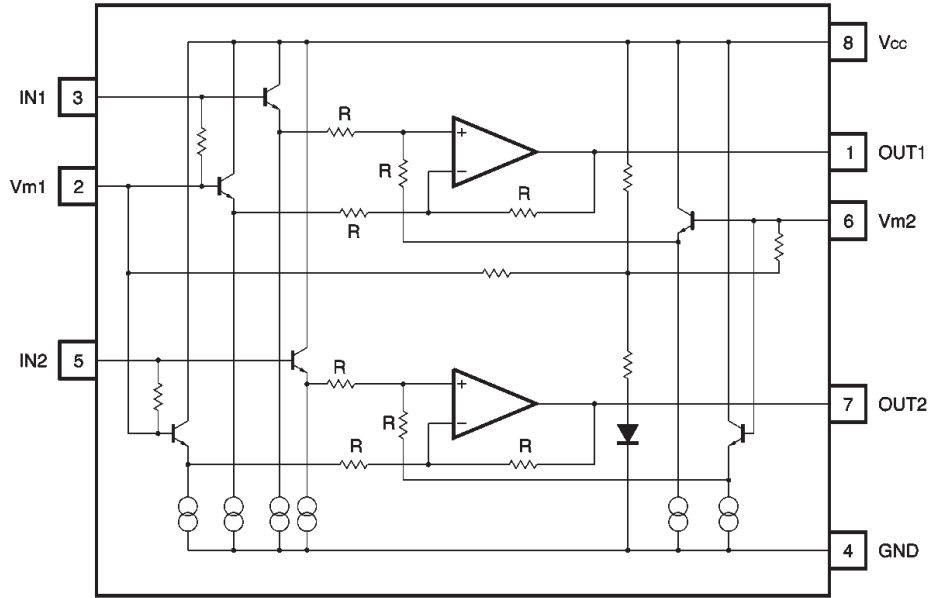

BA3121N

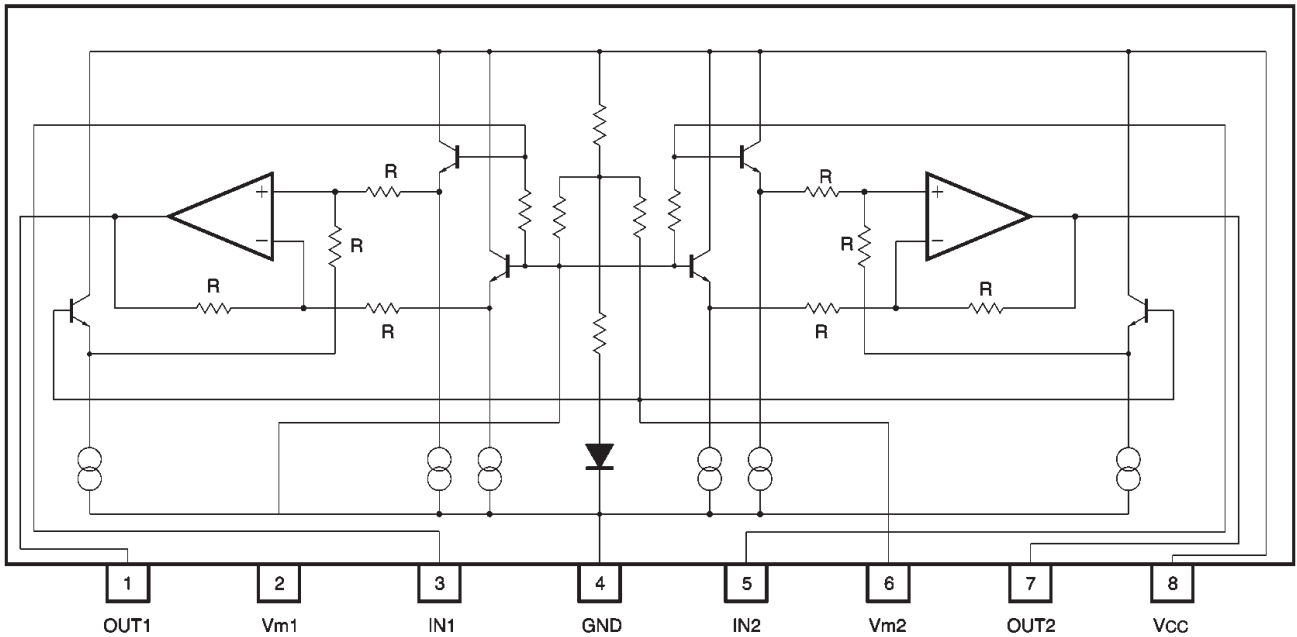

●Electrical characteristics (unless otherwise noted,  $T_a = 25^\circ\text{C}$ ,  $V_{CC} = 12\text{V}$ ,  $f = 1\text{kHz}$ ,  $R_g = 1.8\text{k}\Omega$ )

Parameter	Symbol	Min.	Typ.	Max.	Unit	Conditions
Quiescent current	$I_Q$	5.6	9.0	14.0	mA	$V_{IN}=0V_{rms}$
Output noise voltage	$V_{NO}$	—	3.5	8.0	$\mu V_{rms}$	BPF=20Hz~20kHz
Voltage gain	$G_V$	-1.5	-0.04	1.5	dB	$V_O=-10\text{dBm}$ , $R_g=0\Omega$
Maximum output voltage	$V_{OM}$	1.8	2.0	—	$V_{rms}$	THD=0.1%, $V_{CC}=8\text{V}$
Total harmonic distortion	THD	—	0.002	0.02	%	$V_O=0.7V_{rms}$
Common-mode rejection ratio	CMRR	41	57	—	dB	
Common-mode voltage	$V_{CM}$	2.5	3.75	—	$V_{rms}$	$V_{CC}=8\text{V}$ , CMRR=40dB
Ripple rejection ratio	RR	72	80	—	dB	$f_{RR}=100\text{Hz}$ , $V_{RR}=-10\text{dBm}$ , $R_g=0\Omega$
Channel separation	CS	—	82	—	dB	$V_{IN}=-10\text{dBm}$ , $R_g=1.8\text{k}\Omega/\text{OPEN}$
Slew rate	SR	—	2.0	—	$\text{V}/\mu\text{s}$	
Input resistance	$R_{IN}$	44	55	66	$\text{k}\Omega$	

◎Not designed for radiation resistance.

● Measurement circuits

BA3121/BA3121F

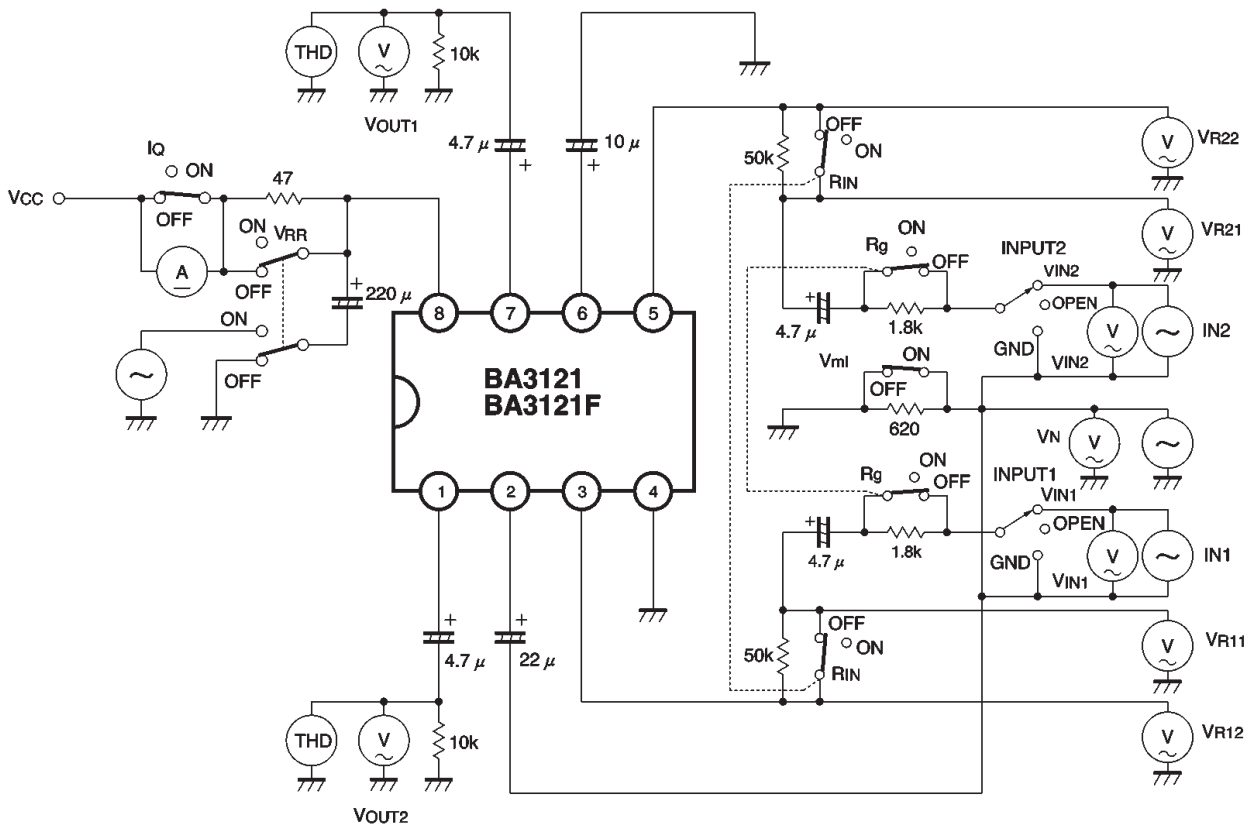

Fig. 1

BA3121N

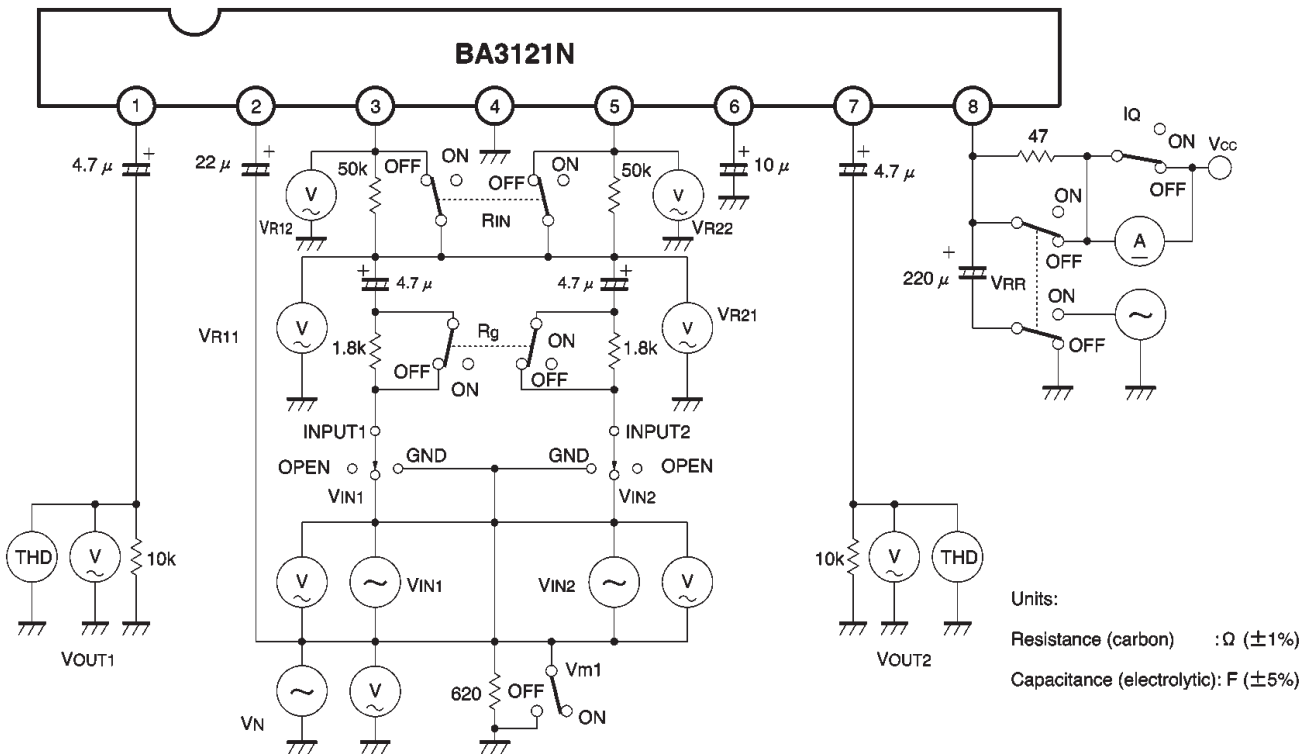

Fig. 2

Units:  
Resistance (carbon) : Ω (±1%)  
Capacitance (electrolytic): F (±5%)

●Circuit operation

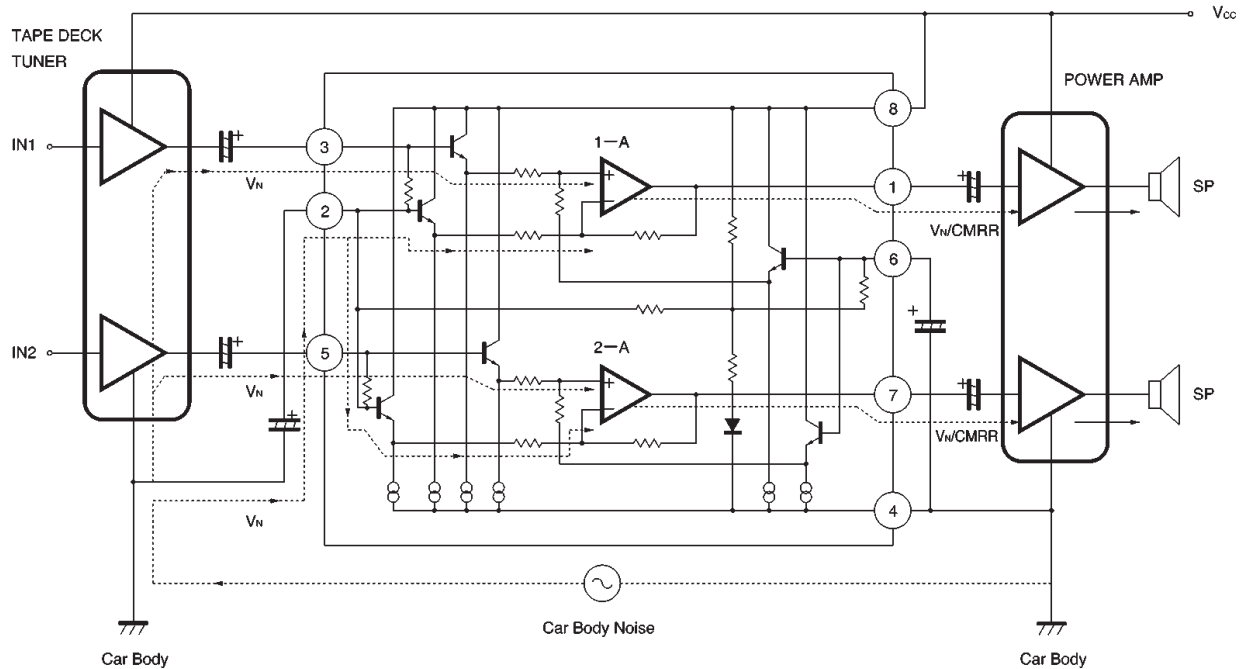

Fig. 3 Flow of noise in car-audio systems

Car-audio systems are earthed to the car body, and for this reason, electrical noise generated by the car electrics can enter the power amplifier input via the chassis, and become audible.

The BA3121 makes use of the common-mode rejection characteristics of an operational amplifier to eliminate this noise. Without the BA3121 noise enters the power amplifier input directly, when used, the CMMR of operational amplifiers 1-A and 2-A eliminates the noise.

Principles of noise elimination:

To obtain the output voltage ( $e_o$ )

$$V_i = \frac{R_4}{(R_3 + R_4)} \cdot e_2 \quad (1)$$

$$e_o = -\frac{R_2}{R_1} e_1 + \frac{R_1 + R_2}{R_1} \cdot V_i \quad (2)$$

From (1) and (2)

$$\begin{aligned} e_o &= -\frac{R_2}{R_1} e_1 + \frac{R_1 + R_2}{R_1} \cdot \frac{R_4}{(R_3 + R_4)} \cdot e_2 \\ &= -\frac{R_2}{R_1} \cdot (e_1 - e_2) + \frac{R_1 R_4 - R_2 R_3}{R_1 (R_3 + R_4)} \cdot e_2 \end{aligned}$$

Ideally, if  $R_1 R_4 = R_2 R_3$ , and  $e_1 = e_2$ , the noise voltage will become zero. However, due to mismatching between the resistors, difference in the noise voltages ( $e_1$  and  $e_2$ ), and tolerances in the operational amplifier, a noise voltage does result.

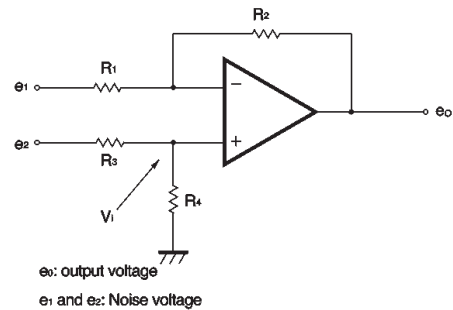

Fig. 4 The principle of noise rejection

With the BA3121, the elimination level of the noise is expressed as:  $CMMR = 20 \log (e_o / e_i)$  ( $e_i = e_1 = e_2$ ) Therefore,  $CMRR \geq 41 \text{dB}$  can be guaranteed.

●Operation notes

- (1) Maintain a ratio of 2: 1 for the values of the capacitors connected to pin 2 ( $V_{m1}$ ) and pin 6 ( $V_{m2}$ ) to keep the ripple rejection ratio stable. If this ratio is maintained, the ripple rejection ratio will not vary significantly even if the capacitance values are halved.
- (2) If the value of the capacitor connected to pin 2 ( $V_{m1}$ ) in the example is doubled, the bass-region CMMR will be +6dB, and if it is halved, it will be -6dB (see Fig. 16).

●Application example

BA3121/BA3121F

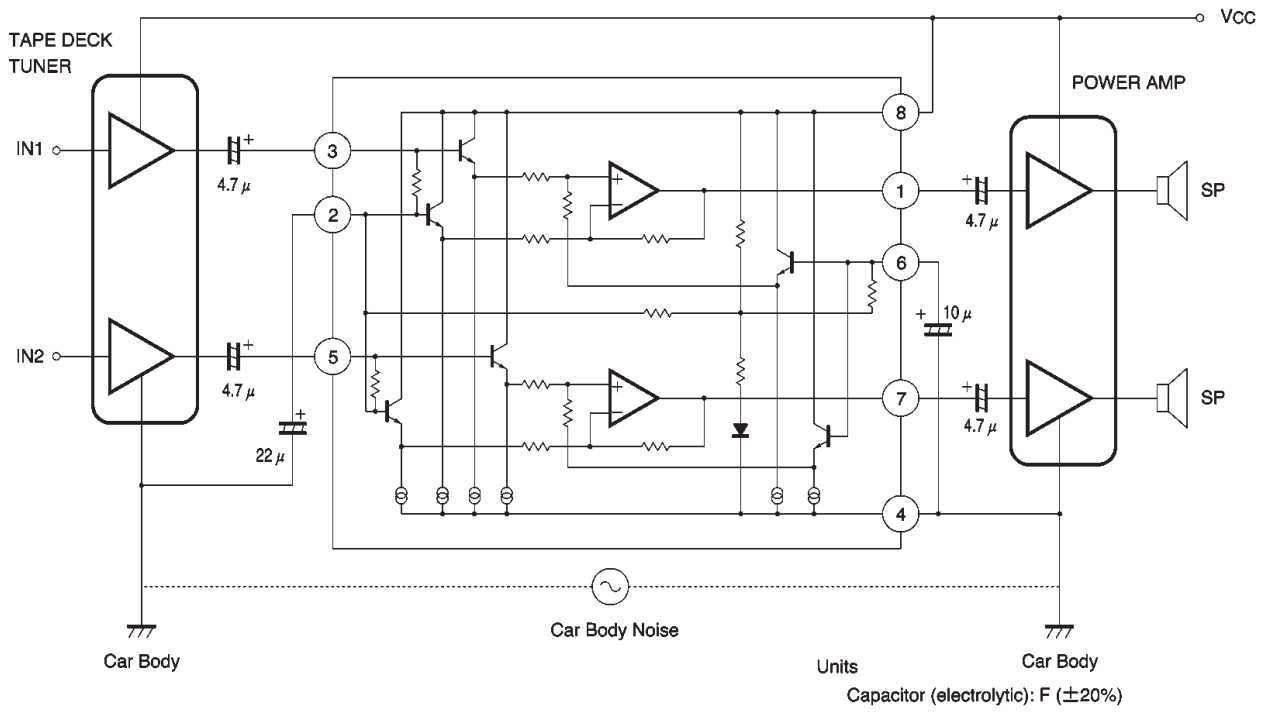

Fig. 5

BA3121N

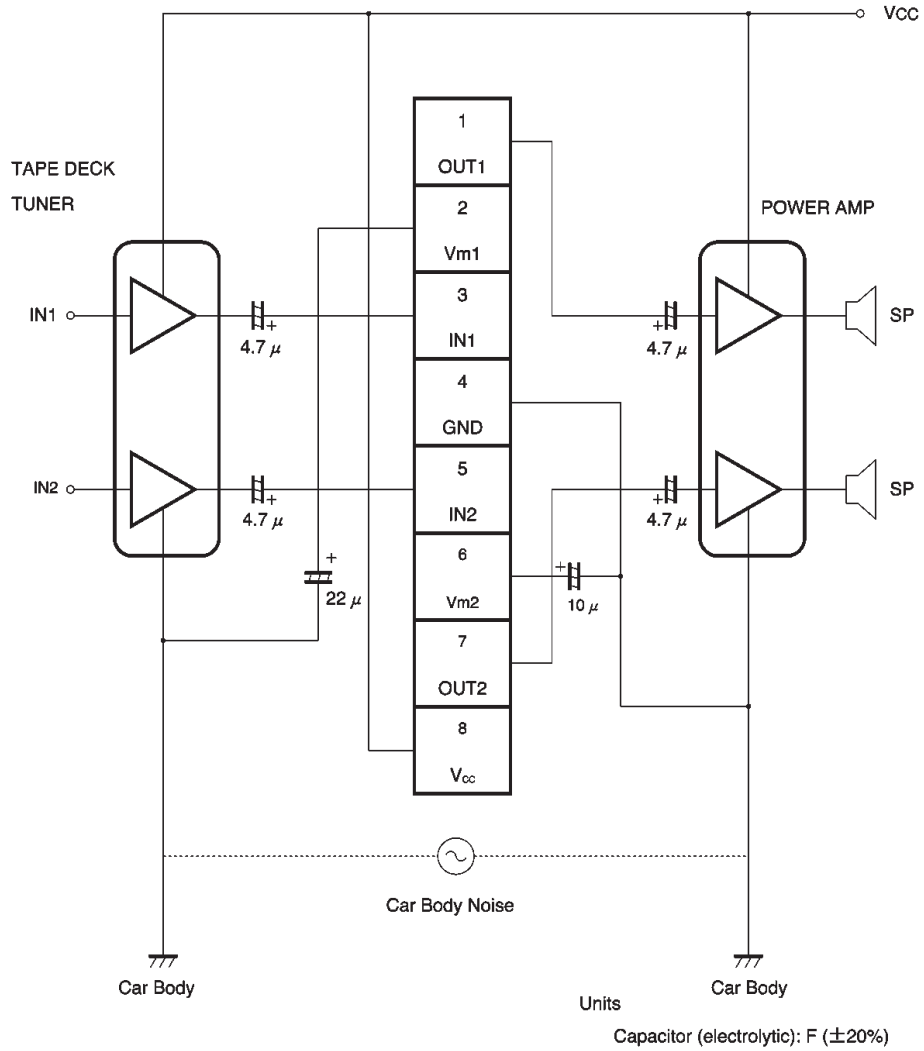

Fig. 6

●Electrical characteristics curves

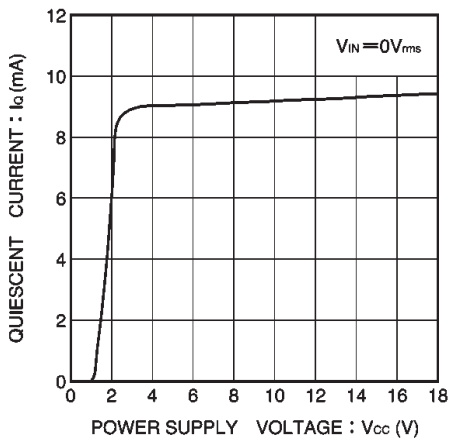

Fig. 7 Quiescent current vs. power supply voltage

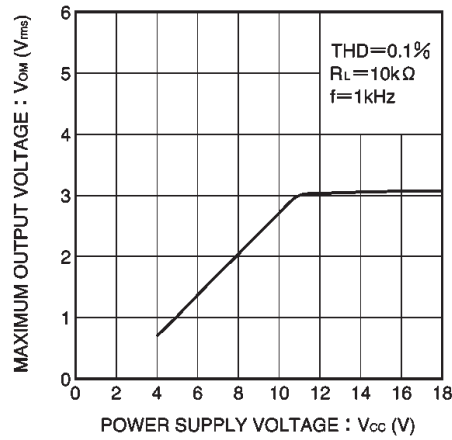

Fig. 8 Maximum output voltage vs. power supply voltage

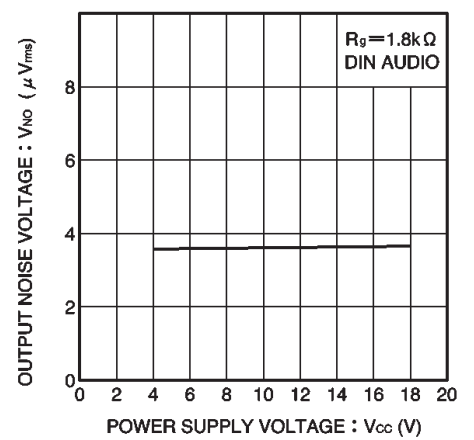

Fig. 9 Output noise voltage vs. power supply voltage

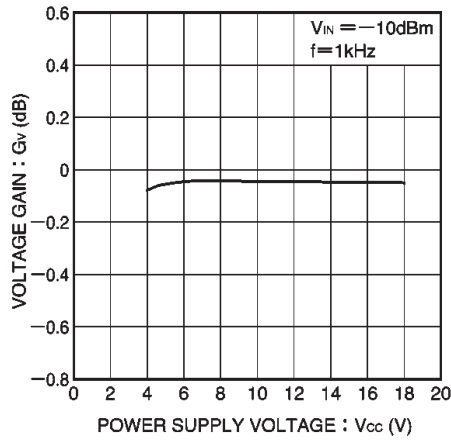

Fig. 10 Voltage gain vs. power supply voltage

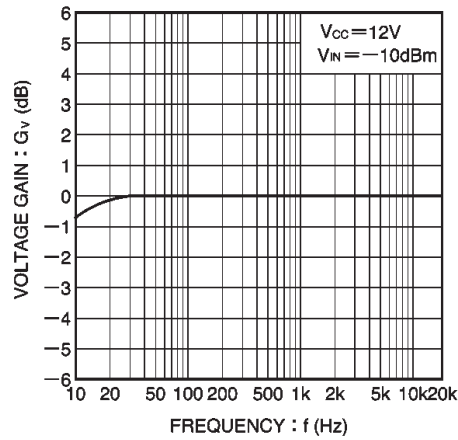

Fig. 11 Voltage gain vs. frequency

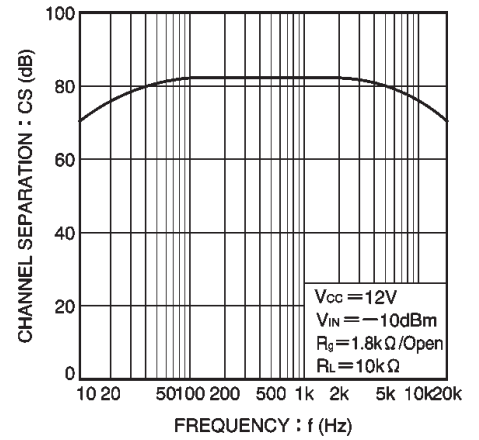

Fig. 12 Channel separation vs. frequency

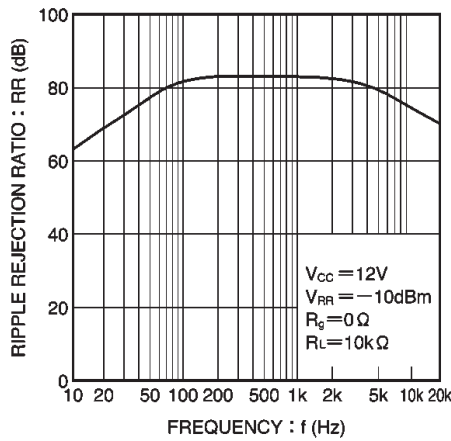

Fig. 13 Ripple rejection ratio vs. frequency

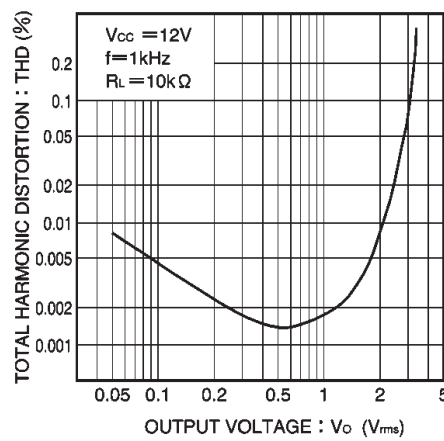

Fig. 14 Total harmonic distortion vs. output voltage

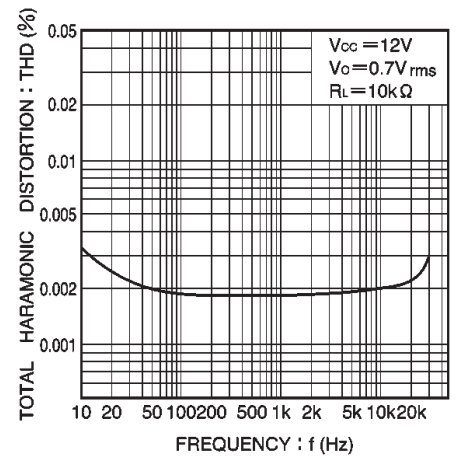

Fig. 15 Total harmonic distortion vs. frequency

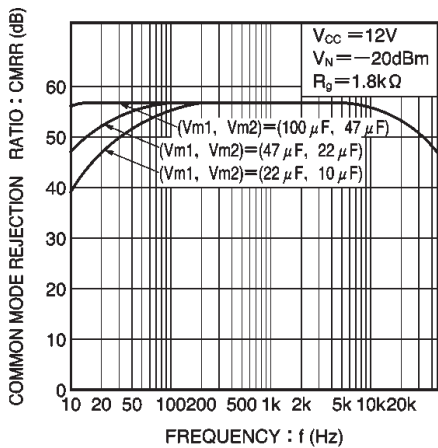

Fig. 16 Common-mode rejection ratio vs. frequency

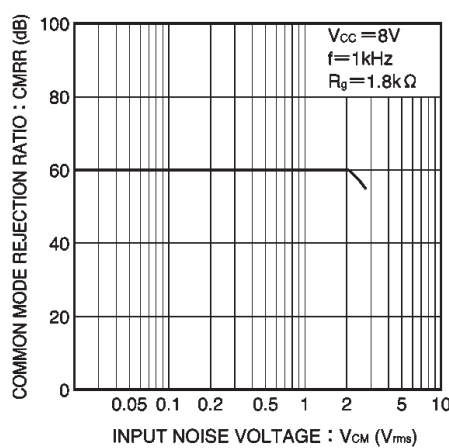
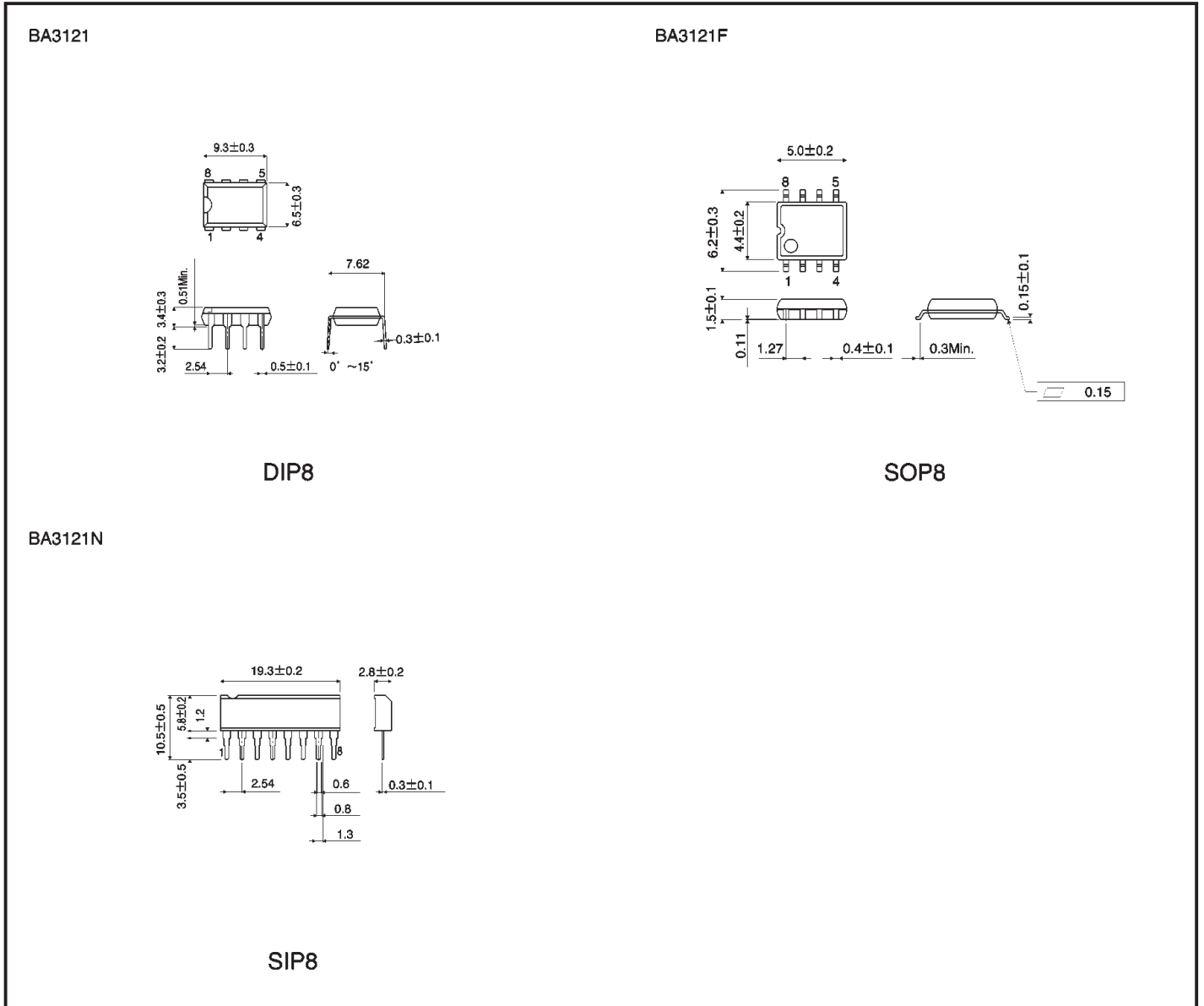

Fig. 17 Common-mode rejection ratio vs. input voltage



● External dimensions (Units: mm)



# MEMO

# MEMO

### Notes

- No technical content pages of this document may be reproduced in any form or transmitted by any means without prior permission of ROHM CO.,LTD.
- The contents described herein are subject to change without notice. The specifications for the product described in this document are for reference only. Upon actual use, therefore, please request that specifications to be separately delivered.
- Application circuit diagrams and circuit constants contained herein are shown as examples of standard use and operation. Please pay careful attention to the peripheral conditions when designing circuits and deciding upon circuit constants in the set.
- Any data, including, but not limited to application circuit diagrams information, described herein are intended only as illustrations of such devices and not as the specifications for such devices. ROHM CO.,LTD. disclaims any warranty that any use of such devices shall be free from infringement of any third party's intellectual property rights or other proprietary rights, and further, assumes no liability of whatsoever nature in the event of any such infringement, or arising from or connected with or related to the use of such devices.
- Upon the sale of any such devices, other than for buyer's right to use such devices itself, resell or otherwise dispose of the same, no express or implied right or license to practice or commercially exploit any intellectual property rights or other proprietary rights owned or controlled by ROHM CO., LTD. is granted to any such buyer.
- Products listed in this document use silicon as a basic material.  
Products listed in this document are no antiradiation design.

The products listed in this document are designed to be used with ordinary electronic equipment or devices (such as audio visual equipment, office-automation equipment, communications devices, electrical appliances and electronic toys).

Should you intend to use these products with equipment or devices which require an extremely high level of reliability and the malfunction of which would directly endanger human life (such as medical instruments, transportation equipment, aerospace machinery, nuclear-reactor controllers, fuel controllers and other safety devices), please be sure to consult with our sales representative in advance.

#### About Export Control Order in Japan

Products described herein are the objects of controlled goods in Annex 1 (Item 16) of Export Trade Control Order in Japan.

In case of export from Japan, please confirm if it applies to "objective" criteria or an "informed" (by MITI clause) on the basis of "catch all controls for Non-Proliferation of Weapons of Mass Destruction.