

# DBL 1019

## AM TUNER SYSTEM

The DBL 1019 is a AM electronic tuner IC with high performance. It is greatly improved cross modulation characteristic.

### FUNCTIONS

- RF wide-band AGC, Attenuator Driver, Local OSC with ALC, Local OSC Buffer, Mixer, IF Amp, IF AGC, Detector, Signal Meter.

### FEATURES

- Low noise
- $V_{CC}$  variation compensation
- the local OSC buffer output facilitates designing of electronic tuner system, frequency display and etc.
- The narrow band signal meter output is usable as auto search stop signal.
- The excellent cross modulation characteristics prevent not only adjacent-channel interference but also interference caused by all channels with in broadcast band.
- The OSC with ALC improves tracking error.
- Double balanced differential MIX

### APPLICATIONS

- The AM car radios and the home receivers

### MAXIMUM RATINGS

Characteristics	Symbol	Rating	Unit
Supply Voltage	$V_{CC}$	16	V
Supply Current	$I_{CC}$	41	mA
MIX Output and IF Amp Output Voltage	$V_{OUT}$	24	V
MIX Input and RF Amp 1 input Voltage	$V_{IN}$	5.6	V
Local OSC Current	$I_{OSC}$	2	mA
Power Dissipation	$P_D$	730	mW
Operating Temperature	$T_{opr}$	-20 ~ +70	°C
Storage Temperature	$T_{stg}$	-40 ~ +125	°C

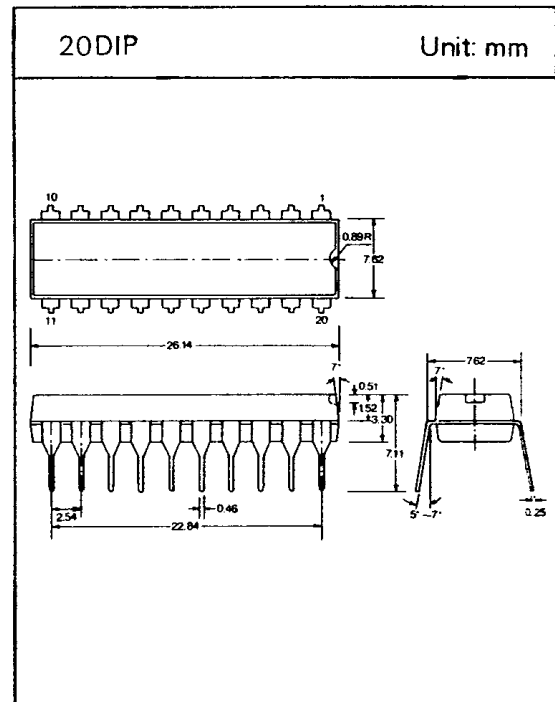

- Recommended supply voltage :  $V_{CC} = 8V$
- Operating Supply Voltage range :  $V_{CC} = 7.5V \sim 12V$

# DBL 1019

## □ BLOCK DIAGRAM

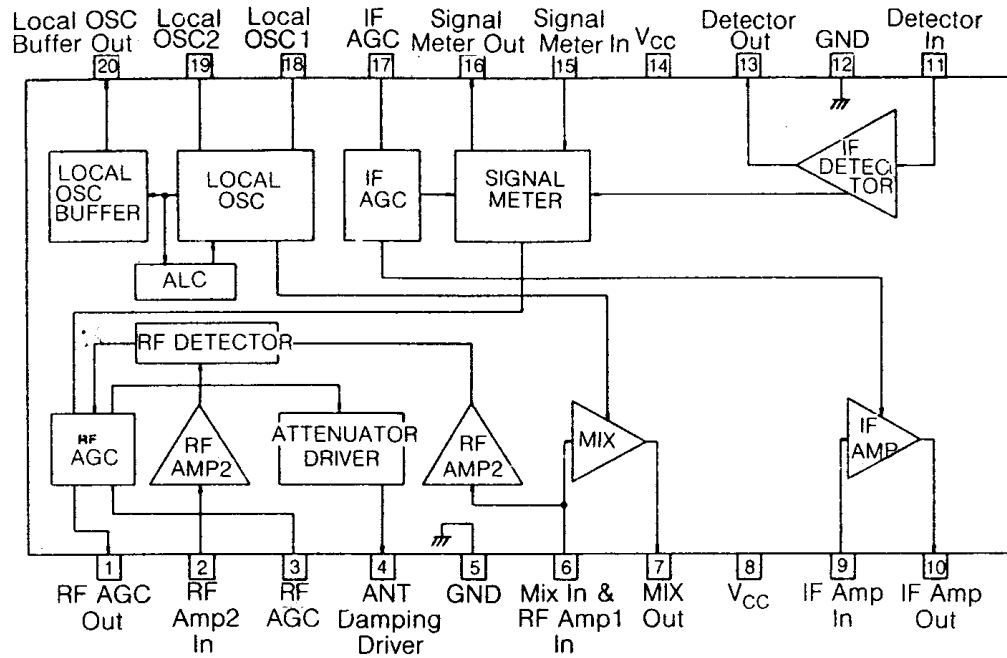

## □ TEST CIRCUIT

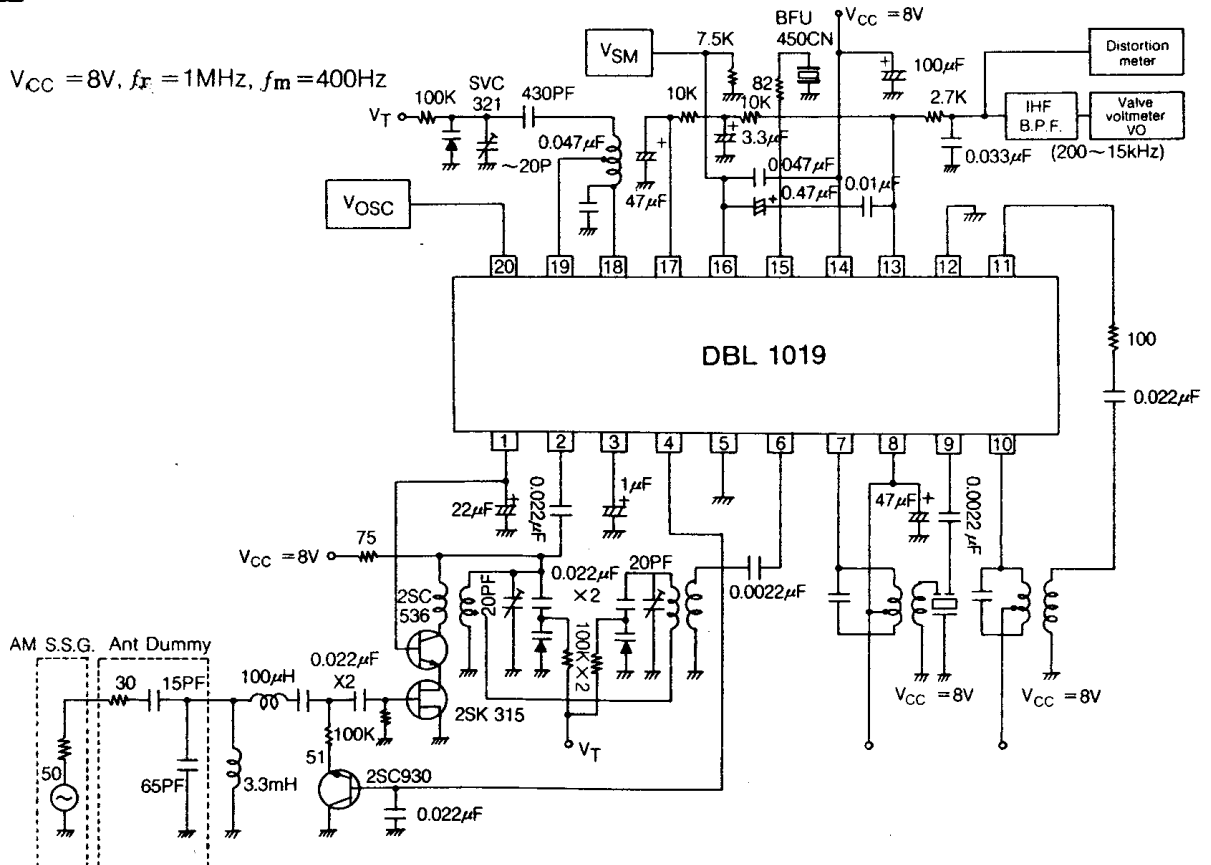

# DBL 1019

## ELECTRICAL CHARACTERISTICS

(Unless otherwise specified,  $T_a = 25^\circ\text{C}$ ,  $V_{CC} = 8\text{V}$ ,  $f_r = 1\text{MHz}$ ,  $f_m = 400\text{Hz}$ )

Characteristic	Symbol	Test Condition	Min.	Typ.	Max.	Unit
Quiescent Current	$I_{CCQ}$	—	13.5	22.5	32.5	mA
Supply Current	$I_{CC}$	130dB $\mu$ Input	20	30	41	mA
Detector Output	$V_{OD1}$	16dB $\mu$ Input 30% mod.	-29	-25	-21	dBm
	$V_{OD2}$	74dB $\mu$ Input 30% mod.	-15	-12	-9	dBm
Signal to Noise Ratio	S/N	74dB $\mu$ Input 30% mod	51	56	—	dB
Total Harmonic Distortion	THD1	74dB $\mu$ Input 30% mod.	—	0.3	1	%
	THD2	74dB $\mu$ Input 80% mod.	—	0.3	2	%
	THD3	130dB $\mu$ Input 80% mod.	—	0.4	2	%
Signal Meter Output	$V_{SM1}$	Quiescent	—	0	0.3	V
	$V_{SM2}$	130dB $\mu$ Input	3.5	5	7.5	V
Input Voltage at Signal Meter Output 1V	$V_{IN}$	$V_{SM} = 1\text{V}$	18	24	30	dB $\mu$
Local OSC Buffer Output	$V_{OSC}$ (BUF)	—	320	380	—	mVrms
Quieting sensitivity	QS	S/N = 20dB	—	25	—	dB $\mu$
Detection Output Variation	$\Delta V_{OD}$	Input 74dB $\mu \rightarrow 130\text{dB}\mu$	—	0.2	—	dB
Wide-Band AGC On State Input	$WB_{AGC}$	Interference 1.4MHz non mod. Reception 1MHz quiescent Input for ANT Damping ON.	—	82	—	dB $\mu$
Local OSC Variation Within broadcast band	$\Delta V_{OSC}$	$V_{OSCL} - V_{OSCH}$	—	15	—	mVrms
Signal Meter Band	$V_{SM-BW1}$	74dB $\mu$ Input, frequency at which output is reduced to 1/2	—	$\pm 1.5$	—	KHz
	$V_{SM-BW2}$	74dB $\mu$ Input, frequency at which output is reduced to 1/10	—	-4.5/+7	—	KHz
Selectivity	SEL	30% mod $\pm 10\text{KHz}$ , $WB_{AGC}$ : "OFF"	—	43	—	dB
IF Interference	IF. I.	$f_r = 600\text{KHz}$ , $WB_{AGC}$ : "OFF"	—	77.5	—	dB
Image Frequency Interference	IM. I.	$f_r = 1400\text{KHz}$ , $WB_{AGC}$ : "OFF"	—	52	—	dB

# DBL 1019

## □ ELECTRICAL CHARACTERISTICS

(Unless otherwise specified,  $T_a = 25^\circ\text{C}$ ,  $V_{CC} = 8\text{V}$ ,  $f_r = 1\text{MHz}$ ,  $f_m = 400\text{Hz}$ )

Characteristic	Symbol	Test Condition	Min.	Typ.	Max.	Unit
Quiescent Current	$I_{CC0}$	—	13.5	22.5	32.5	mA
Supply Current	$I_{CC}$	130dB $\mu$ Input	20	30	41	mA
Detector Output	$V_{OD1}$	16dB $\mu$ Input 30% mod.	-29	-25	-21	dBm
	$V_{OD2}$	74dB $\mu$ Input 30% mod.	-15	-12	-9	dBm
Signal to Noise Ratio	S/N	74dB $\mu$ Input 30% mod	51	56	—	dB
Total Harmonic Distortion	THD1	74dB $\mu$ Input 30% mod.	—	0.3	1	%
	THD2	74dB $\mu$ Input 80% mod.	—	0.3	2	%
	THD3	130dB $\mu$ Input 80% mod.	—	0.4	2	%
Signal Meter Output	$V_{SM1}$	Quiescent	—	0	0.3	V
	$V_{SM2}$	130dB $\mu$ Input	3.5	5	7.5	V
Input Voltage at Signal Meter Output 1V	$V_{IN}$	$V_{SM} = 1\text{V}$	18	24	30	dB $\mu$
Local OSC Buffer Output	$V_{OSC}$ (BUF)	—	320	380	—	mVrms
Quieting sensitivity	QS	S/N = 20dB	—	25	—	dB $\mu$
Detection Output Variation	$\Delta V_{OD}$	Input 74dB $\mu \rightarrow 130\text{dB}\mu$	—	0.2	—	dB
Wide-Band AGC On State Input	$WB_{AGC}$	Interference 1.4MHz non mod. Reception 1MHz quiescent Input for ANT Damping ON.	—	82	—	dB $\mu$
Local OSC Variation Within broadcast band	$\Delta V_{OSC}$	$V_{OSCL} - V_{OSCH}$	—	15	—	mVrms
Signal Meter Band	$V_{SM-BW1}$	74dB $\mu$ Input, frequency at which output is reduced to 1/2	—	$\pm 1.5$	—	KHz
	$V_{SM-BW2}$	74dB $\mu$ Input, frequency at which output is reduced to 1/10	—	4.5/+7	—	KHz
Selectivity	SEL	30% mod $\pm 10\text{KHz}$ , $WB_{AGC}$ : "OFF"	—	43	—	dB
IF Interference	IF. I.	$f_r = 600\text{KHz}$ , $WB_{AGC}$ : "OFF"	—	77.5	—	dB
Image Frequency Interference	IM. I.	$f_r = 1400\text{KHz}$ , $WB_{AGC}$ : "OFF"	—	52	—	dB

# DBL 1019

## INFORMATION IN USING IC (continued)

6. To make the ANT damping constant within the receiving band, change the application circuit as shown below.

○ Reference Circuit

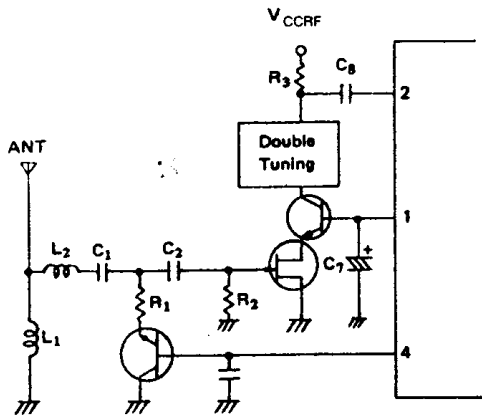

○ Changing Circuit

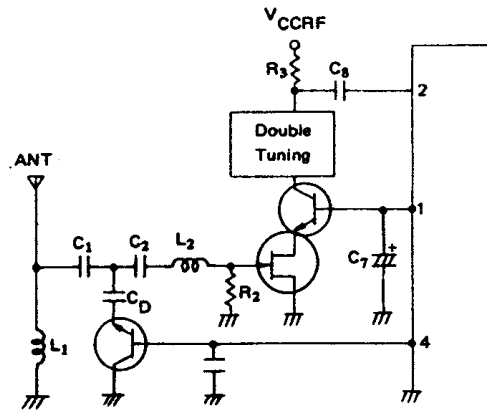

$C_D$  is 2000PF to 3000pF or thereabouts

$L_2$  Damping(600KHz~1400KHz)  $\left\{ \begin{array}{l} \text{Reference Circuit: } -15\text{dB} \\ \text{Changing Circuit: } -4\text{dB} \end{array} \right.$

7. The  $L_2$  is used to remove the SW band.

If the RF stage is double-tuned, the difference in sensitivity within the RF band almost disappears, thereby leading to worse spurious characteristic.

8. The DBL1019 contains 2-channel wide-band AGC.

The pin 6 detects and undesired signal within the RF band and wide-band AGC is applied. This detection sensitivity is determined inside the IC. The pin 2 detects and undesired signal outside the RF band. This detection sensitivity is determined by  $R_3$ . When 1mVrms( $f=1\text{MHz}$ ) signal is applied to pin 2, AGC operates.

9. In the AGC circuit of the test circuit the presence of an undesired signal of high strength within the receiving band may cause the desired signal to be suppressed when the desired signal is low or medium in strength. Shown below is the circuit configuration where the necessary measures are taken against this suppression.

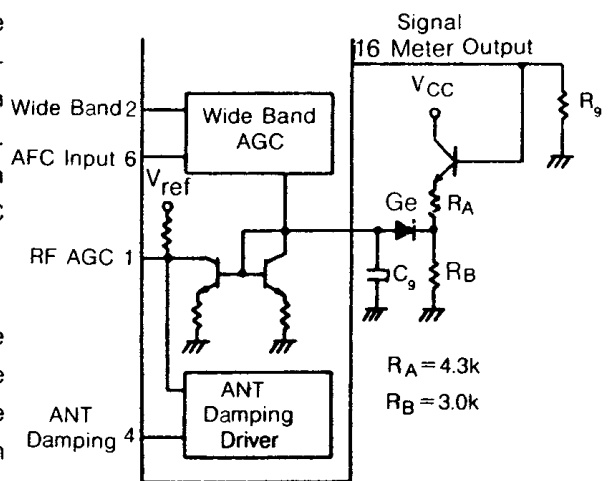

# DBL 1019

## □ INFORMATION IN USING IC (continued)

10. The circuit shown below is available to stabilize the transient response of the signal meter output at the search stop mode.

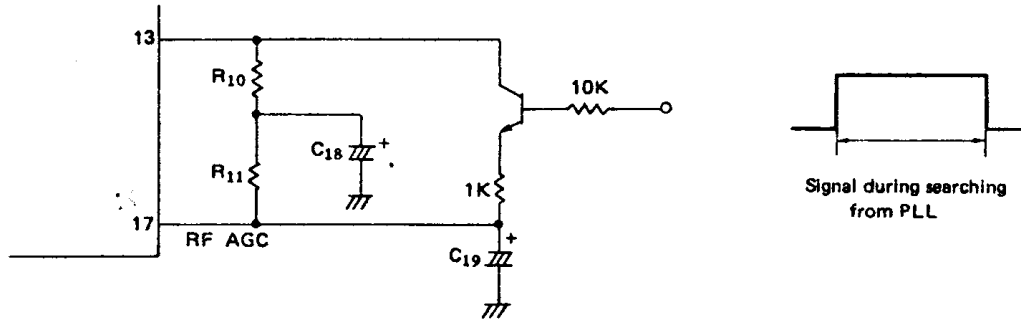

11. When using MW, no additional resistor is required.

But when using LW (approximately  $50^{\circ}\text{C}$  or greater), additionally connect a resistor of  $27\text{k}\Omega$  across pins 18 and 19 against increase in local OSC level.

12. For improvement in image frequency interference change the RF double tuning coil as follows, and the image frequency interference becomes 63dB at  $f_r = 1400\text{KHz}$ . (Q point of the tuning circuit must not be decreased with tuning resistor  $100\text{k}\Omega$ )

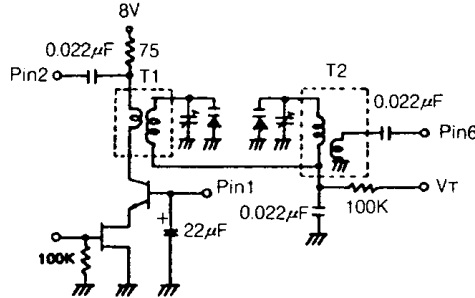

13. Shown below is cross modulation characteristic.

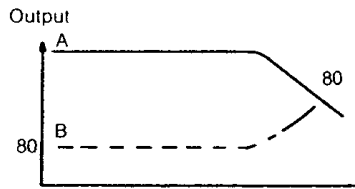

A: Desired signal  $83\text{dB}\mu$  400Hz 30% mod.  
The strength of an undesired signal (non mod) causes the desired signal to be suppressed.

B: Desired signal  $80\text{dB}\mu$  non-mod.  
The strength of an undesired signal (40Hz 80% mod) causes interference to occur.

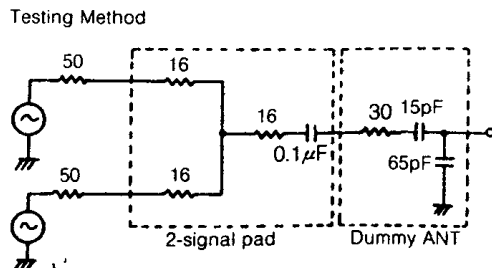

# DBL 1019

## ☐ COIL DATA (for test circuit)

### 1. RF double Tuning Coil

#### Primary (T1)

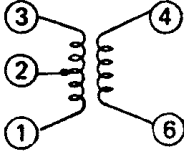

#### Bottom View

Item	L ( $\mu$ H)	Turns		
Pin No.	1-3	1-2	2-3	4-6
Value	224	2	82	37

#### Secondary (T2)

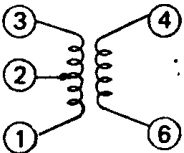

#### Bottom View

Item	L ( $\mu$ H)	Turns		
Pin No.	1-3	1-2	2-3	4-6
Value	224	2	82	15

### 2. IFT(1) Coil(T3)

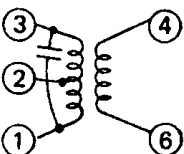

#### Bottom View

Item	C <sub>O</sub> (pF)	f(KHz)	Q <sub>O</sub>	Turns		
Pin No.	1-3	—	1-3	1-2	2-3	4-6
Value	180	450	115	69	77	14

#### High Selectivity Type

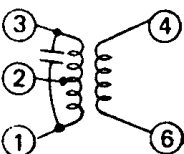

#### Bottom View

Item	C <sub>O</sub> (pF)	f(KHz)	Q <sub>O</sub>	Turns		
Pin No.	1-3	—	1-3	1-2	2-3	4-6
Value	180	450	45	49	103	27

### 3. IFT(2) Coil(T4)

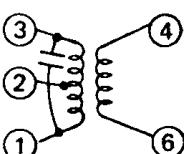

#### Bottom View

Item	C <sub>O</sub> (pF)	f(KHz)	Q <sub>O</sub>	Turns		
Pin No.	1-3	—	1-3	1-2	2-3	4-6
Value	180	455	110	115	37	6

### 4. OSC Coil(T5)

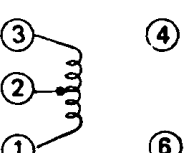

#### Bottom View

Item	L ( $\mu$ H)	Turns	
Pin No.	1-3	1-2	2-3
Value	118	29	29

# DBL 1019

## TYPICAL PERFORMANCE CHARACTERISTICS

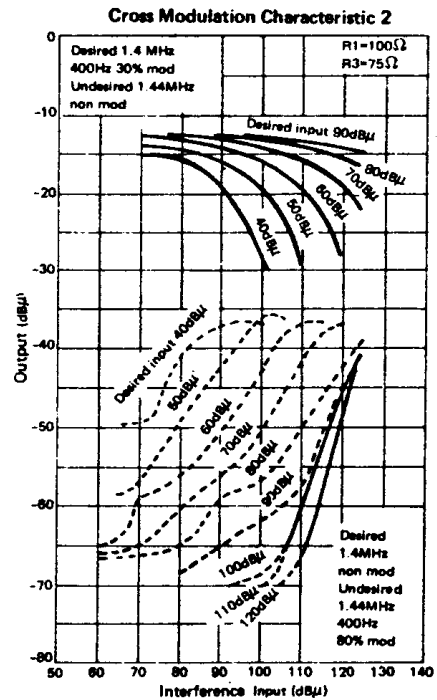
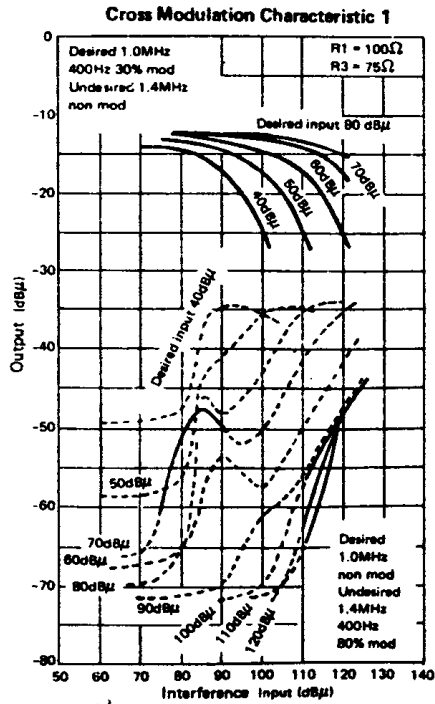
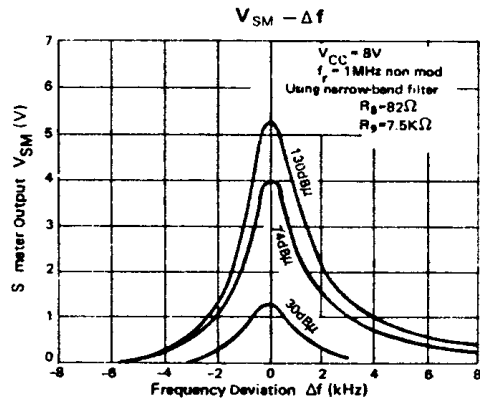
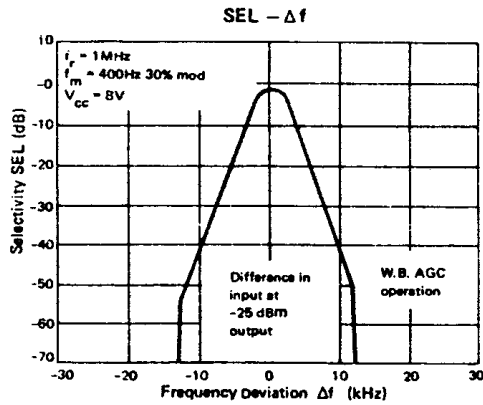
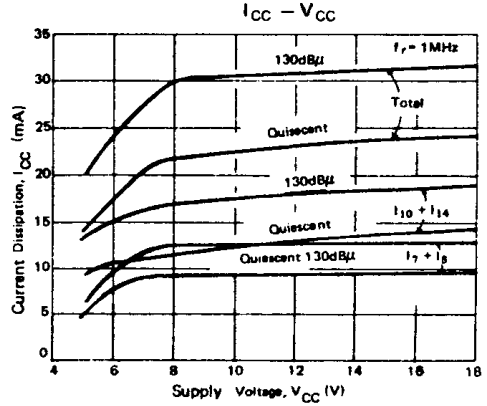
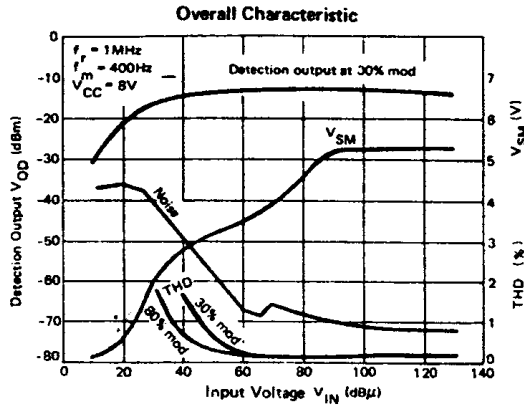



# DBL 1019

## APPLICATION CIRCUIT

