

KA3082

Bi-Directional DC Motor Driver

Features

- Built-in Brake Function for Stable Brake Characteristics.
- Built-in Element to Absorb a Surge Current Derived From Changing Motor Direction and Braking Motor Drive.
- Motor Speed Control by an External Voltage.
- Stable Motor Direction Change.
- Interfaces With CMOS Devices.
- Built-in the Thermal Shut Down Circuit (165°C).
- Low Standby Current. (6.5mA)

Description

The KA3082 is a monolithic integrated circuit designed for driving bi-directional DC motor with braking and speed control, and it is suitable for the loading motor driver of VCR, CDP, and TOY systems. The speed control can be achieved by adjusting the external voltage of the speed control pin. It has two pins of logic inputs for controlling the forward/ reverse and braking.

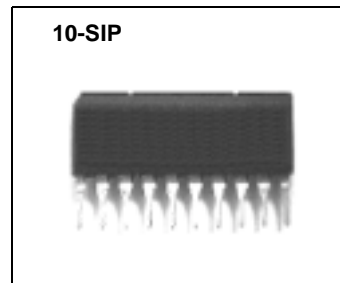

Target Applications

- Video Cassette Recorder (VCR) Loading Motor
- Low Current DC Motor Such as Audio or Video Equipment.
- General DC Motor

Ordering Information

Device	Package	Operating Temp.
KA3082B	10-SIP	-25°C ~ +75°C

Pin Assignments

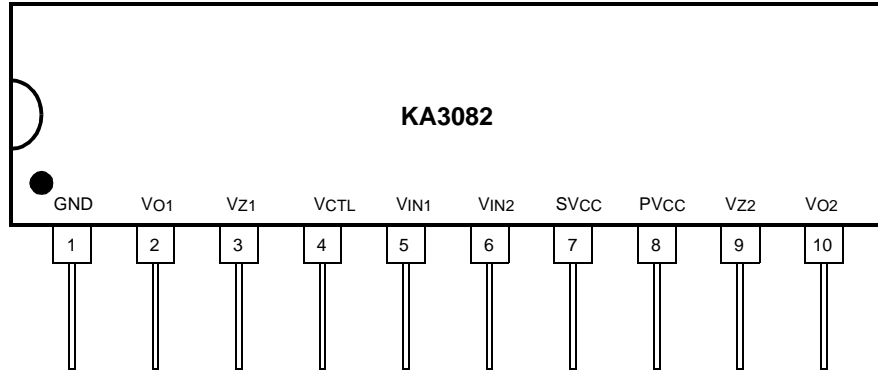

Pin Definitions

Pin Number	Pin Name	I/O	Pin Function Description
1	GND	-	Ground
2	VO1	O	Output 1
3	VZ1	-	Phase Compensation
4	VCTL	I	Motor Speed Control
5	VIN1	I	Input 1
6	VIN2	I	Input 2
7	SVCC	-	Supply Voltage (Signal)
8	PVCC	-	Supply Voltage (Power)
9	VZ2	-	Phase Compensation
10	VO2	O	Output 2

Internal Block Diagram

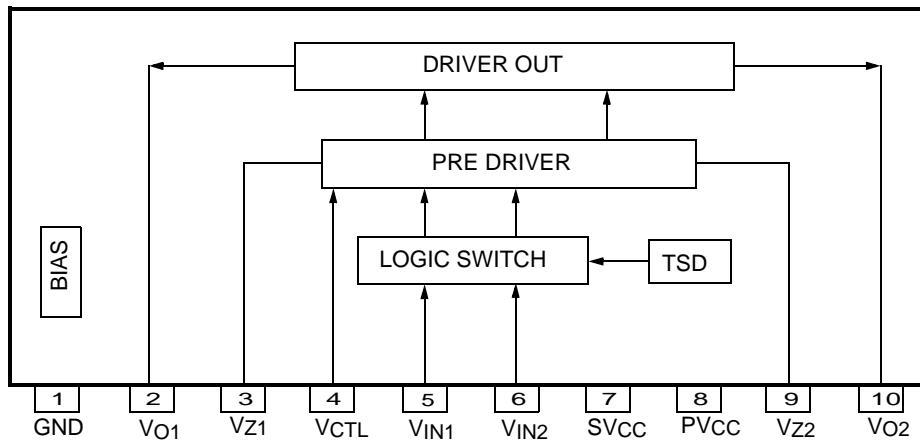

Equivalent Circuits

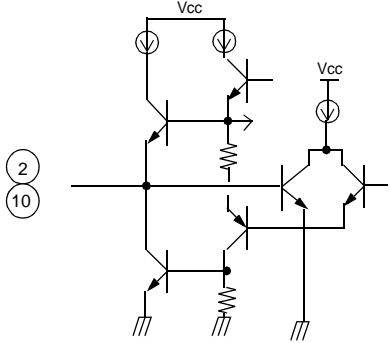
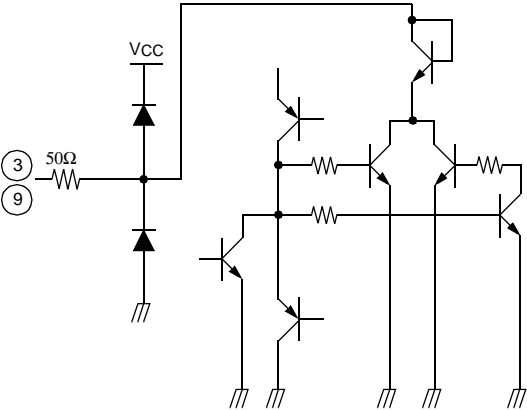
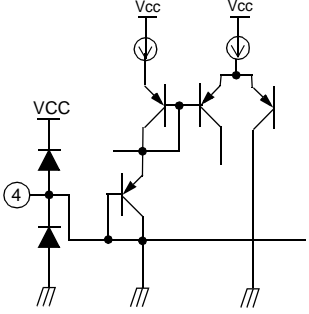
Description	Pin No.	Internal Circuit
Output	2, 10	
Phase Compensation	3, 9	
Speed Control	4	

Equivalent Circuit (Continued)

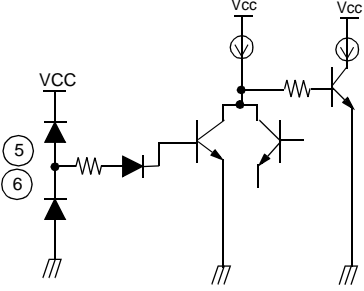
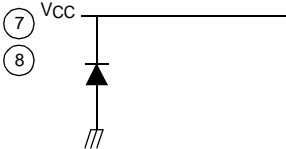
Description	Pin No.	Internal Circuit
Input	5, 6	
SVcc PVcc	7 8	

Absolute Maximum Ratings (Ta=25°C)

Parameter	Symbol	Value	Unit	Remark
Supply Voltage	VCCmax	18	V	-
Maxium Output Current	IOmax	1.6 ^{note1}	A	-
Power Dissipation	Pd	1.2 ^{note2}	W	-
Operating Temperature	TOPR	-25 ~ +75	°C	-
Storage Temperature	TSTG	-55 ~ +125	°C	-

Note:

- Duty 1 / 100, pulse width 500µs
- 1) When mounted on glass epoxy PCB (76.2 × 114 × 1.57mm)
2) Power dissipation reduces 9.6mV / °C for using above Ta=25°C.
3) Do not exceed Pd and SOA(Safe Operating Area).

Power Dissipation Curve

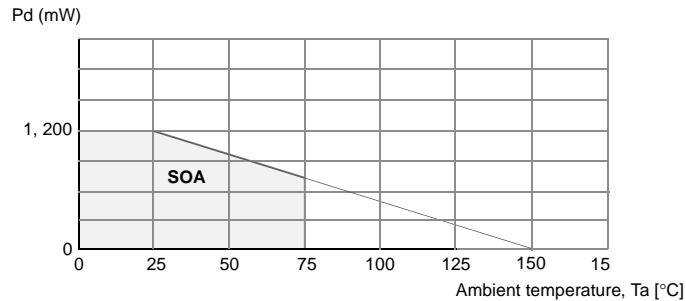

Recommened Operating Conditions (Ta=25°C)

Parameter	Symbol	Operating voltage range	Unit
Operating Supply Voltage	SVCC,PVCC	7 ~ 18	V

Note:

Caution 1) $PVCC \leq SVCC$

Caution 2) When PVCC is above 16V, the VCTL must be opened or $8.5 \leq VCTL \leq PVCC$

Electrical Characteristics (Ta=25°C, VCC=SVCC=PVCC=12V)

Parameter	Symbol	Conditions	Min.	Typ.	Max.	Unit
Quiescent Current	ICC2	Pin5 & 6: GND, RL=∞	4	6.5	9.5	mA
Min. Input-on Current 1	IIN1	RL=∞, pin5=IIN1, pin6=L	-	10	30	μA
Min. Input-on Current 2	IIN2	RL=∞, pin5=L, pin6=IIN	-	10	30	μA
Input Threshold Voltage 1	VITH1	RL=∞, pin5=VIN, pin6=L	1.0	1.3	1.6	V
Input Threshold Voltage 2	VITH2	RL=∞, pin5=L, pin6=VIN	1.0	1.3	1.6	V
Output Leakage Current 1	IOL1	RL=∞, pin5 & 6=GND	-	0.01	1	mA
Output Leakage Current 2	IOL2	RL=∞, pin5 & 6=GND	-	0.01	1	mA
Zener Current 1	Iz1	RL=∞, pin5=H, pin6=L	-	0.85	1.5	mA
Zener Current 2	Iz2	RL=∞, pin5=L, pin6=H	-	0.85	1.5	mA
Output Voltage 1	VO1	RL=60Ω, pin5=H, pin6=L	6.6	7.2	7.6	V
Output Voltage 2	VO2	RL=60Ω, pin5=L, pin6=H	6.6	7.2	7.6	V
Saturation Voltage 1 (Upper)	V SAT1	IO=300mA	-	1.9	2.3	V
Saturation Voltage 2 (Upper)	VSAT2	IO=500mA	-	1.9	2.3	V
Saturation Voltage 1 (Lower)	VSAT3	IO=300mA	-	0.25	0.5	V
Saturation Voltage 2 (Lower)	VSAT4	IO=500mA	-	0.4	0.65	V

Application Information

1. Thermal Shut Down Circuit

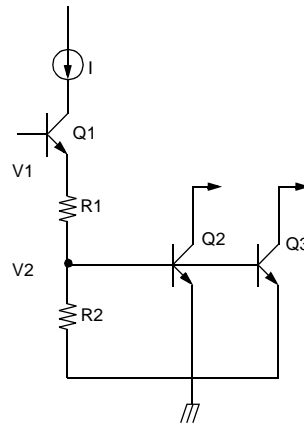

When $T_a = 25^\circ\text{C}$, Q2 & Q3 are Turn-off and output stage operate normally.

$$V_1 = I \times (R_1 + R_2)$$

$$V_2 = R_2 / (R_1 + R_2) \times V_1 = 0.37\text{V}$$

When $T_a = 165^\circ\text{C}$, Q2 & Q3 become Turn-on and it turn-off the output stage.

$$0.70\text{V} - 0.37\text{V} = 330\text{mV} \text{ (When Q2 \& Q3 are Turn-on, } V_{beQ2} = V_{beQ3} = 0.70\text{V)}$$

And temperature coefficient of Q2 = Q3 = $-2\text{mV}/^\circ\text{C}$

$$\therefore \text{T.S.D: } 330\text{mV} / 2\text{mV} = 165^\circ\text{C}$$

2. Logic Input & Output Table

Input		Output		Motor
Pin #5	Pin #6	Pin #2	Pin #10	
Low	Low	Low	Low	Brake
High	Low	High	Low	Forward
Low	High	Low	High	Reverse
High	High	Low	Low	Brake

Input High is above 2.0V.

Input Low is below 0.7V.

3. Logic Switch Circuit

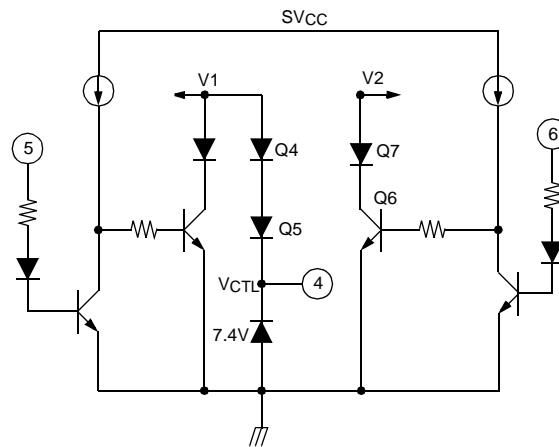

This circuit define reference voltage of output.

When pin #5 is "H" and pin #6 is "L",

$$- V1 = V_{ZD} + V_{BEQ4} + V_{BEQ5} \approx 8.9V$$

$$- V2 = V_{BEQ7} + V_{SATQ6} \approx 0.87V$$

V1 and V2 are related with the output voltage of the motor and change according to the voltage of pin #4 (VCTL).

4. Drive Output Circuit

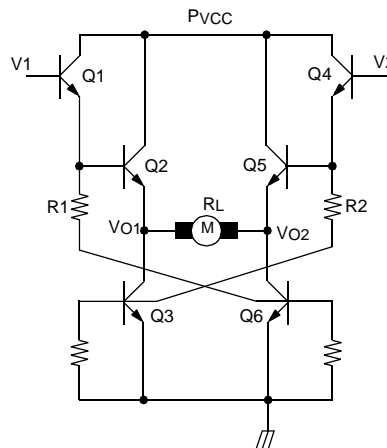

$$V1 = 8.9V$$

$$V2 = 0.87V$$

$$VO1 = V1 - V_{BEQ1} - V_{BEQ2}$$

$$VO2 = V_{Q6SAT}$$

$$VO = VO1 - VO2$$

$$= V1 - V_{BEQ1} - V_{BEQ2} - V_{Q6SAT}$$

$$I_{RL} = (VO1 - VO2) / R_L$$

Typical Performance Characteristics

CHARACTERISTIC GRAPHS

1. V_{CC} vs I_{CC}

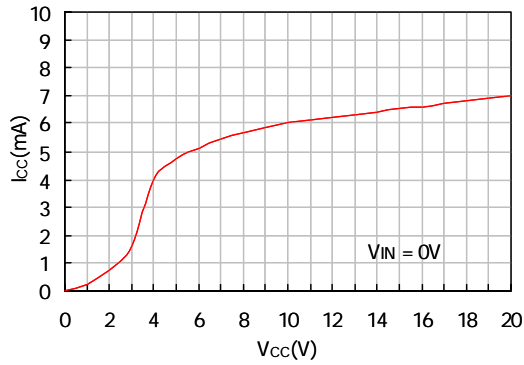

2. Temperature vs I_{CC}

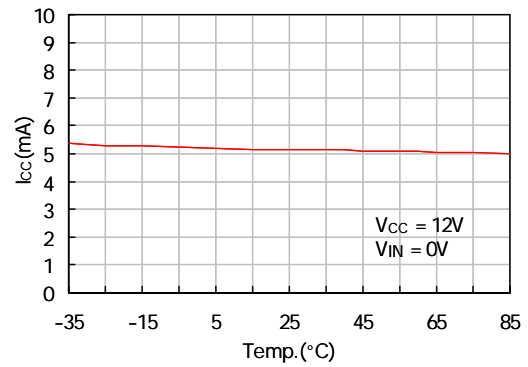

3. V_{CTL} vs. V_o

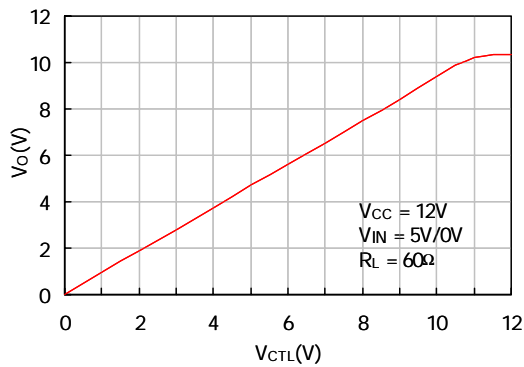

4. Temperature vs. V_o

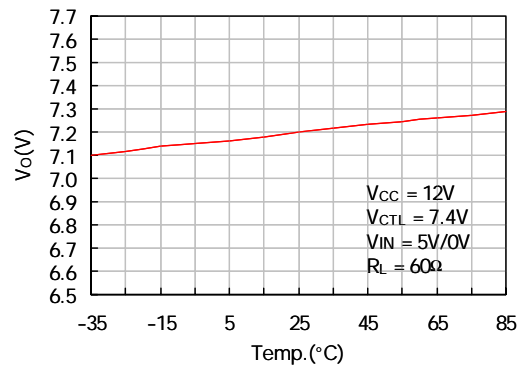

5. I_o vs. V_{SAT} (UPPER)

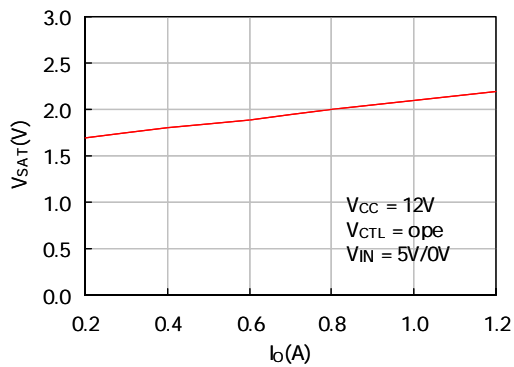

5. I_o vs. V_{SAT} (LOWER)

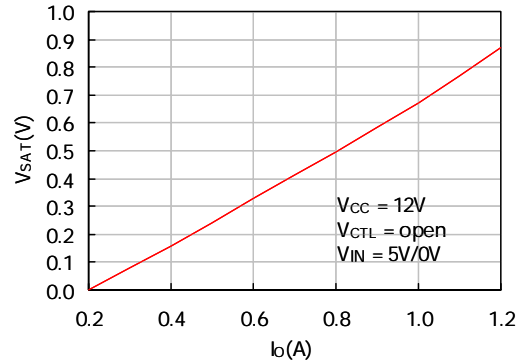

Test Circuits

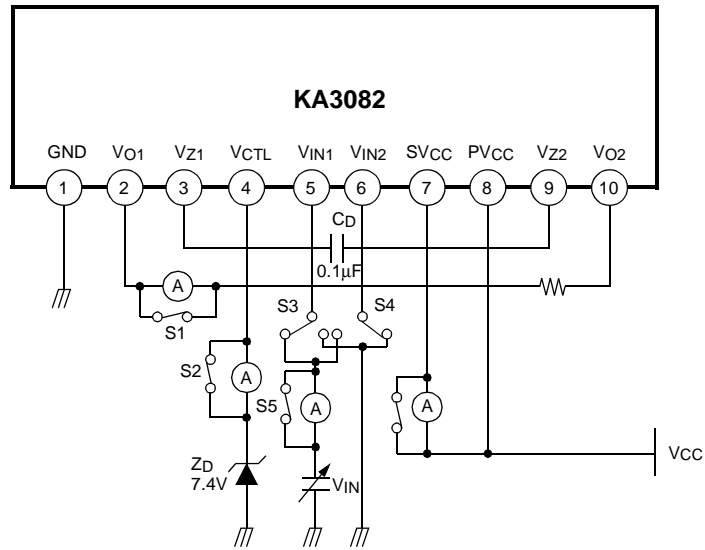

Typical Application Circuits

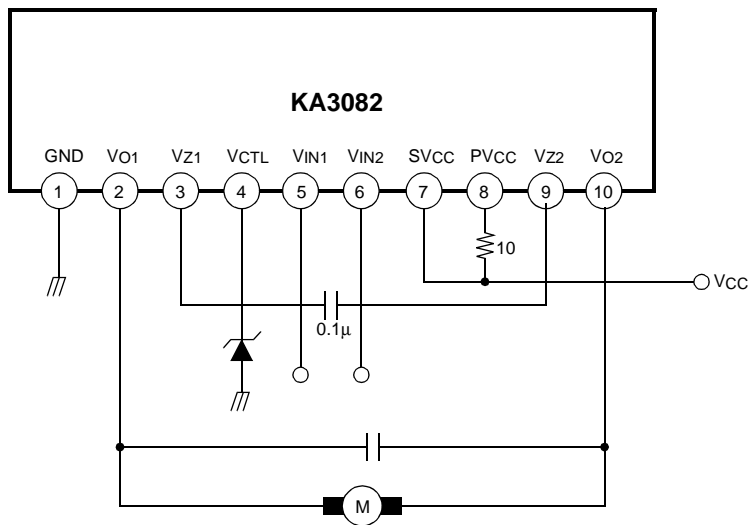

DISCLAIMER

FAIRCHILD SEMICONDUCTOR RESERVES THE RIGHT TO MAKE CHANGES WITHOUT FURTHER NOTICE TO ANY PRODUCTS HEREIN TO IMPROVE RELIABILITY, FUNCTION OR DESIGN. FAIRCHILD DOES NOT ASSUME ANY LIABILITY ARISING OUT OF THE APPLICATION OR USE OF ANY PRODUCT OR CIRCUIT DESCRIBED HEREIN; NEITHER DOES IT CONVEY ANY LICENSE UNDER ITS PATENT RIGHTS, NOR THE RIGHTS OF OTHERS.

LIFE SUPPORT POLICY

FAIRCHILD'S PRODUCTS ARE NOT AUTHORIZED FOR USE AS CRITICAL COMPONENTS IN LIFE SUPPORT DEVICES OR SYSTEMS WITHOUT THE EXPRESS WRITTEN APPROVAL OF THE PRESIDENT OF FAIRCHILD SEMICONDUCTOR CORPORATION. As used herein:

1. Life support devices or systems are devices or systems which, (a) are intended for surgical implant into the body, or (b) support or sustain life, and (c) whose failure to perform when properly used in accordance with instructions for use provided in the labeling, can be reasonably expected to result in a significant injury of the user.
2. A critical component in any component of a life support device or system whose failure to perform can be reasonably expected to cause the failure of the life support device or system, or to affect its safety or effectiveness.