

FM IF/AM TUNER SYSTEM

The KA2247 is a monolithic integrated circuit developed for the radio cassette tape recorder.

FUNCTIONS

- AM SECTION: RF amplifier, Mixer, OSC (with ALC), IF amplifier, Detector, AGC, Tuning indicator.
- FM SECTION: IF amplifier, Quadrature detector, AF preamplifier, Tuning indicator.

FEATURES

- Minimum number of external parts required.
- Very good S/N: FM (81dB), AM (53dB).
- AM oscillator circuit with ALC: Oscillation output voltage of pin 16.
MW 130mV
SW 70mV ~ 90mV
(7MHz) ~ (24MHz)
- Excellent AM whistle performance: Whistle 1% at $V_i = 100\text{dB/m}$.
- Built-in tuning indicator.
- Built-in AM/FM function switch.
- Operating supply voltage range: $V_{cc} = 3\text{V} \sim 8\text{V}$.

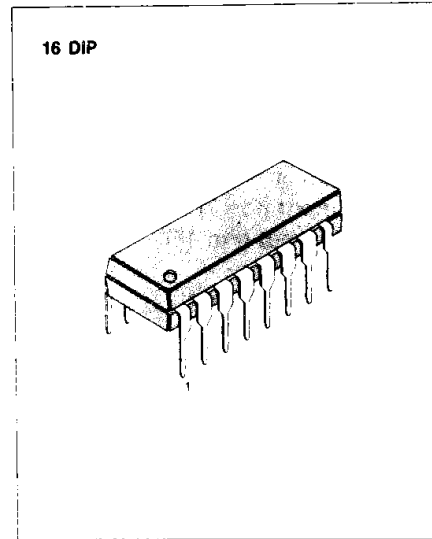

ORDERING INFORMATION

Device	Package	Operating Temperature
KA2247	16 DIP	-20°C ~ +70°C

BLOCK DIAGRAM

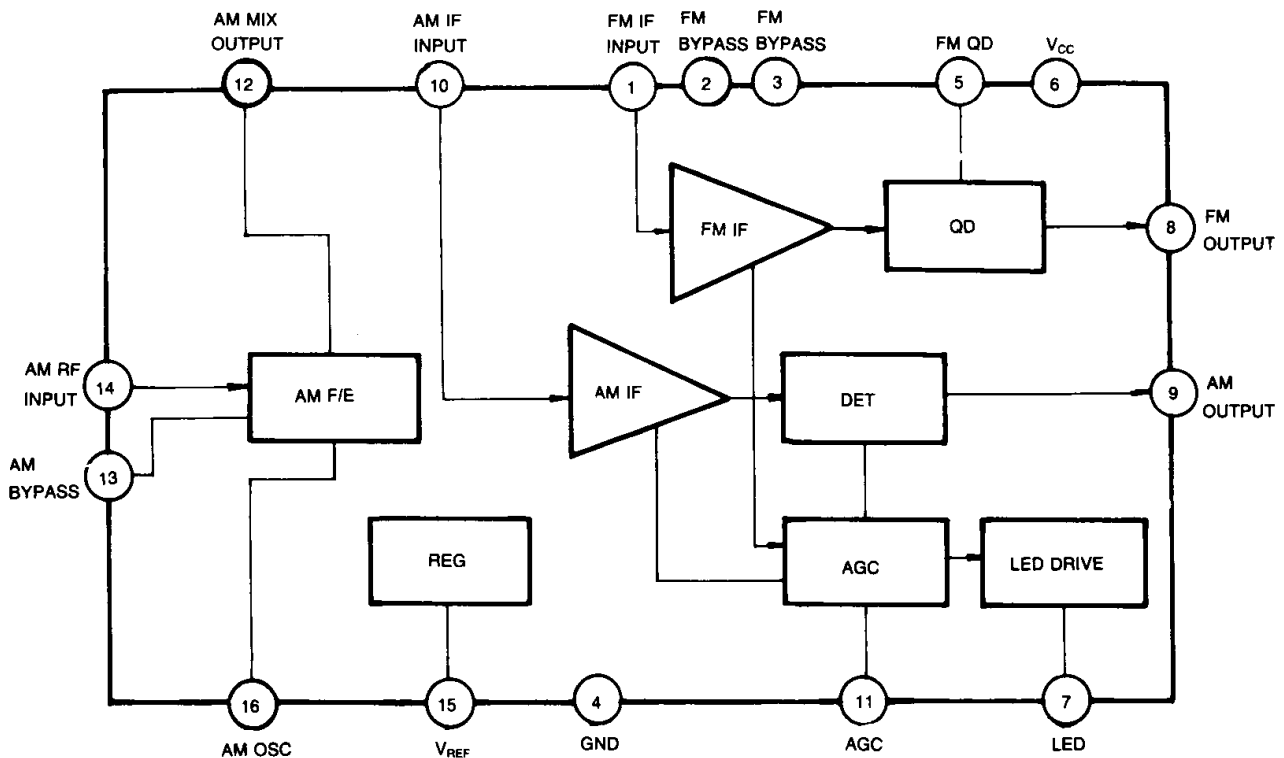

Fig. 1

ABSOLUTE MAXIMUM RATINGS ($T_a = 25^\circ\text{C}$)

Characteristic	Symbol	Value	Unit
Supply Voltage	V_{CC}	9	V
Circuit Current	I_{CC}	50	mA
Input Current (Pin 7)	I_7	20	mA
Output Current (Pin 15)	I_{15}	0.1	mA
Power Dissipation	P_D	450	mW
Operating Temperature	T_{OPR}	-20 ~ +70	$^\circ\text{C}$
Storage Temperature	T_{STG}	-40 ~ +125	$^\circ\text{C}$

ELECTRICAL CHARACTERISTICS

($T_a = 25^\circ\text{C}$, $V_{CC} = 4.5\text{V}$)FM Section ($f = 10.7\text{MHz}$, $\Delta f = \pm 75\text{KHz}$, $f_m = 400\text{Hz}$)

Characteristic	Symbol	Test Conditions	Min	Typ	Max	Unit
Quiescent Circuit Current	I_{CCQ}	$V_i = 0$		8.5	12.0	mA
-3dB Limiting Sensitivity	$V_{i(LIM)}$	$V_o (V_i = 80\text{dB}\mu) - 3\text{dB down}$		35	42	$\text{dB}\mu$
Detector Output Voltage	$V_{O(DET)}$	$V_i = 80\text{dB}\mu$	183	260	367	mV
Total Harmonic Distortion	THD 1	$V_i = 80\text{dB}\mu$		0.55	1.2	%
	THD 2	$V_i = 80\text{dB}\mu$, $\Delta f = \pm 22.5\text{KHz}$		0.05		
AM Rejection Ratio	AMR	$V_i = 80\text{dB}\mu$, AM: $f_m = 1\text{KHz}$, 30% Mod		60		dB
Signal to Noise Ratio	S/N 1	$V_i = 80\text{dB}\mu$	77	81		dB
	S/N 2	$V_i = 80\text{dB}\mu$, $\Delta f = \pm 22.5\text{KHz}$		71		
Tuning Indication Voltage	V_L	$I_{LAMP} = 1\text{mA}$		39	49	$\text{dB}\mu$

AM Section ($f = 1\text{MHz}$, $f_m = 400\text{Hz}$, 30% Mod)

Characteristic	Symbol	Test Conditions	Min	Typ	Max	Unit
Quiescent Circuit Current	I_{CCQ}	$V_i = 0$		7.5	10.5	mA
Detector Output Voltage	$V_{O(DET)1}$	$V_i = 23\text{dB}\mu$	17.3	31	55	mV
Detector Output Voltage	$V_{O(DET)2}$	$V_i = 60\text{dB}\mu$	87	122	174	mV
Total Harmonic Distortion	THD 1	$V_i = 60\text{dB}\mu$		0.45	1.3	%
	THD 2	$V_i = 100\text{dB}\mu$		1.5	3.0	
Signal to Noise Ratio	S/N 1	$V_i = 23\text{dB}\mu$	18.0	21.5		dB
	S/N 2	$V_i = 60\text{dB}\mu$	48	53		
Tuning Indication Voltage	V_L	$I_{LAMP} = 1\text{mA}$	22	30	38	$\text{dB}\mu$
Oscillator Voltage	V_{OSC}	$f = 24\text{MHz}$	60	86	120	mV

TEST CIRCUIT

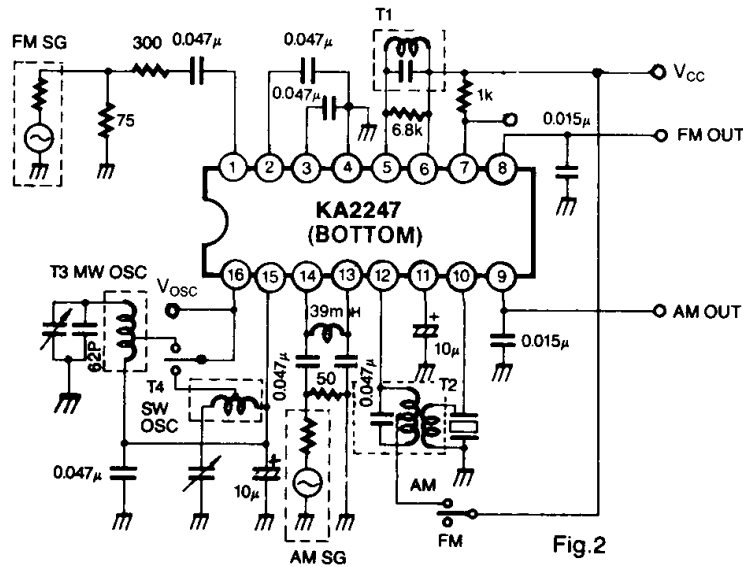
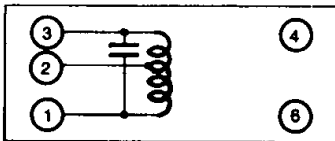

Fig.2

3

COIL SPECIFICATIONS

T1 FM IF (DET)



C _o (PF)	f (MHz)	Q _o	URNS
1-3		1-3	1-3
56	10.7	95	12

Seoul Jupa
0.12mmφ UEW

T2 AM IFT (MIX OUT)

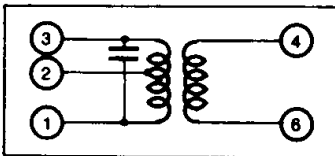

C _o (PF)	f (KHz)	Q _o	URNS		
1-3		1-3	1-2	2-3	4-6
180	455	110	90	62	8

Seoul Jupa
0.07mmφ UEW

T3 (MW OSC)

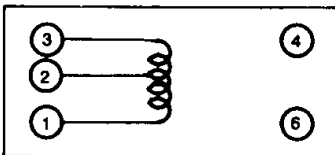

f (KHz)	L (μH)	Q _o	URNS	
	1-3	1-3	1-2	2-3
796	140	140	32	32

Seoul Jupa
0.07mmφ UEW

T4 (SW OSC)

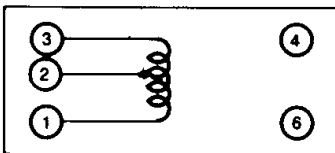

L (μH)	Q _o	URNS	
1-3	1-3	1-2	2-3
12	80	12	12

Seoul Jupa
0.1mmφ UEW