

# UTC KA22427 LINEAR INTEGRATED CIRCUIT

## I-CHIP AM/FM RADIO IC

### DESCRIPTION

UTC KA22427 is a one-chip AM/FM radio integrated circuit that is suitable for portable radio applications. It includes AM amplifier, local OSC, AM mixer, AM/FM amplifier, AM AGE, FM AGE circuit and also class b Audio Power Amplifier.

### FEATURES

- \*Low external components count.
- \*Wide operating voltage : 3 - 13 V.
- \*Internal regulated supply for constant current operation.
- \*DC selection of AM/FM mode.

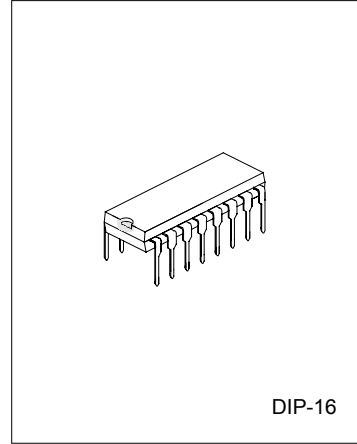

DIP-16

### BLOCK DIAGRAM

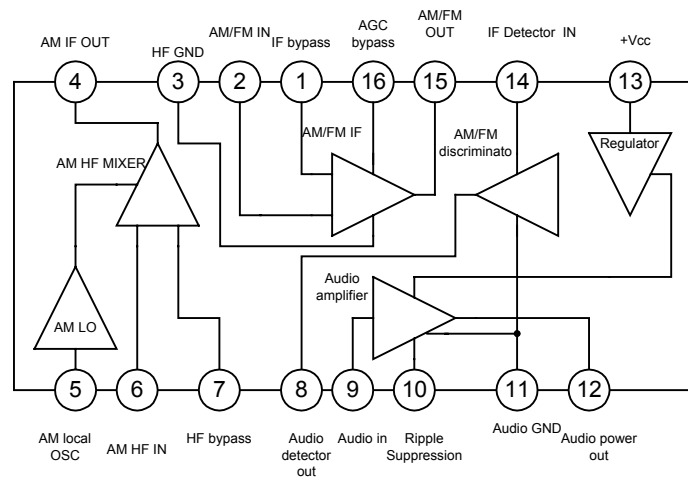

### ABSOLUTE MAXIMUM RATING(Ta=25°C)

PARAMETER	SYMBOL	VALUE	UNIT
SUPPLY VOLTAGE	VCC	11	V
SUPPLY CURRENT	ICC	44	mA
POWER DISSIPATION	PD	600	mW
THERMAL RESISTANCE	RJ-A	100	°C/W
OPERATING TEMPERATURE	TOPX	-18~65	°C
STORAGE TEMPERATURE	TSTG	-40~125	°C

NOTE: Ta>25°C, DERATE WITH 10mW/°C UNLESS SPECIFIED.

**UTC** UNISONIC TECHNOLOGIES CO., LTD.

1

QW-R110-002.A

# UTCA22427 LINEAR INTEGRATED CIRCUIT

## ELECTRICAL CHARACTERISTICS

PARAMETER	SYMBOL	TEST CONDITIONS	MIN	TYP	MAX	UNIT
Quiescent Circuit Current	ICCQ	SW1→FM,VCC=3V	7	12	17	mA
		SW1→FM,VCC=9V	10	17	23	
Pin 16 Terminal Voltage	V16(FM)	SW1→FM,ICC=42mA	2.0	2.4	3.1	V
Limiting Voltage	VIN(lim)	SW1→FM,VCC=5.5V,-3dB V16=2.4V,VR=Min.		57		dBμV
Internal Regulated Voltage	VCC	SW1→AM,ICC=42mA	12.5	13.2	14.0	V
Pin 16 Voltage	V16(AM)	SW1→AM,VCC=9V	1.4		1.9	V
Signal to Noise Ratio	VO	SW1→AM,VCC=12V,VIN=37dB SW2→45Ω,V16=1.4V	1.5	3.0		V
Maximum Sensitivity	S/N	SW1→AM,VCC=5.5V, SW2→8Ω,VIN=37.5dB	15	20		dB
Power Output	POUT	SW2→8Ω,VCC=5.5V,f=1KHZ VR=Min. THD=10%	0.28			W
Total Harmonic Distortion	THD	SW2→45Ω,ICC=42mA,f=1KHZ VR=Min. VOUT=2V		0.5	4.0	%
Voltage Gain	GV	SW2→8Ω,VCC=5.5V,f=1KHZ VR=Min.		40		dB

## INPUT - OUTPUT IMPEDANCE(Ta=25°C,VCC=6V)

PARAMETER	SYMBOL	TEST CONDITIONS	MIN	TYP	MAX	UNIT
Pin 2 Input ( AM )	Rip2(AM)	f=465KHZ		200		KΩ
Impedance ( AM )	Cip2(AM)	f=465KHZ		3		pF
Pin 2 Input ( FM )	Rip2(FM)	f=10.7MHZ		30		KΩ
Impedance ( FM )	Cip2(FM)	f=10.7MHZ		3.5		pF
Pin 4 Output	Rop4	f=465KHZ		300		KΩ
Impedance	Cop4	f=465KHZ		6		pF
Pin 6 Input	Rip6	f=1MHZ		50		KΩ
Impedance	Cip6	f=1MHZ		5		pF
Pin 14 Input ( AM )	Rip14(AM)	f=465KHZ		300		KΩ
Impedance ( AM )	Cip14(AM)	f=465KHZ		3.5		pF
Pin14 Input ( FM )	Rip14(FM)	f=10.7MHZ		300		KΩ
Impedance ( FM )	Cip14(FM)	f=10.7MHZ		4		pF
Pin15 Output ( AM )	Rop15(AM)	f=465KHZ		300		KΩ
Impedance ( AM )	Cop15(AM)	f=465KHZ		5.5		pF
Pin15 Output ( FM )	Rop15(FM)	f=10.7MHZ		300		KΩ
Impedance ( FM )	Cop15(FM)	f=10.7MHZ		6		pF

**UTC** UNISONIC TECHNOLOGIES CO., LTD. 2

QW-R110-002.A

# UTCKA22427 LINEAR INTEGRATED CIRCUIT

## TEST CIRCUIT

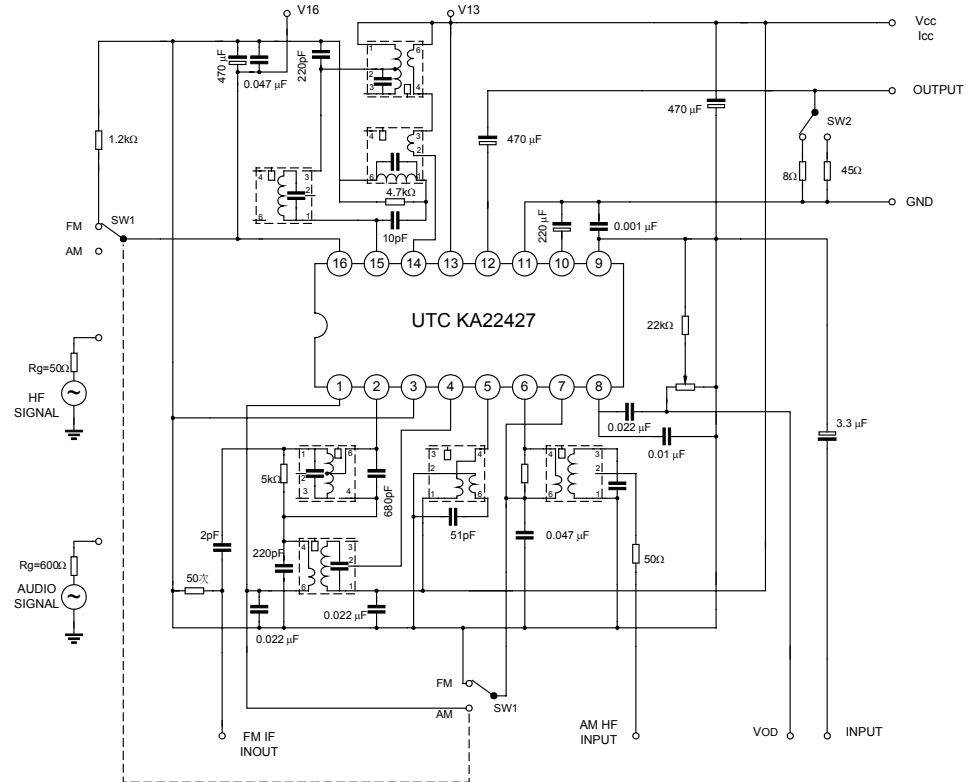

UTC assumes no responsibility for equipment failures that result from using products at values that exceed, even momentarily, rated values (such as maximum ratings, operating condition ranges, or other parameters) listed in products specifications of any and all UTC products described or contained herein. UTC products are not designed for use in life support appliances, devices or systems where malfunction of these products can be reasonably expected to result in personal injury. Reproduction in whole or in part is prohibited without the prior written consent of the copyright owner. The information presented in this document does not form part of any quotation or contract, is believed to be accurate and reliable and may be changed without notice.