

PWM CONTROLLER

The KA7552/3 are switching power control IC for wide operating frequency range. The internal circuits include pulse by pulse current limiting, protection, on/off control by external trigger, low standby current, soft start, and high current totempole output for driving a POWER MOS-FET.

Maximum duty of the KA7552 is 70% and the KA7553 is 46%. When duty is maximum, the input threshold voltage of pin2 & pin8 are not same in KA7552 and KA7553.

FEATURES

- Built-in Drive Circuits for Direct Connection POWER MOSFET ($I_o = \pm 1.5A$)
- Wide Operating Frequency Range (5KHz ~ 600KHz)
- Pulse By Pulse Over Current Limiting
- Over Load Protection
- On/Off Control By External Trigger
- Internal UVLO
- Low Standby Current (Typ. 90uA)
- Soft Start Circuit

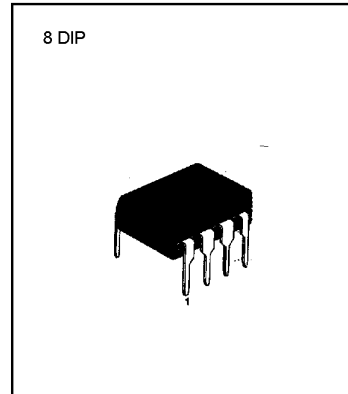

ORDERING IN FORMATION

Device	Package	Operating Temperature
KA7552/3	8 DIP	-25 ~ + 85 °C

BLOCK CIAGRAM

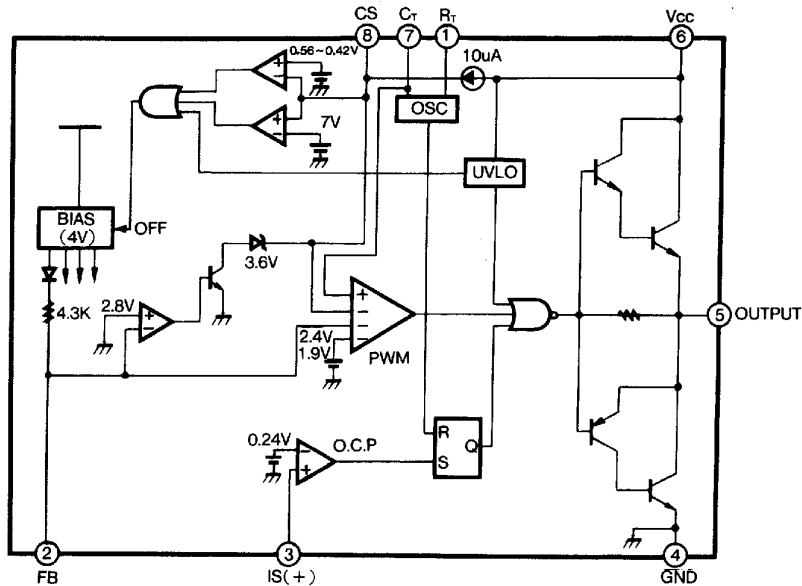

ABSOLUTE MAXIMUM RATINGS

Characteristic	Symbol	Value	Unit
Supply Voltage	V_{CC}	30	V
Output Current	I_O	± 1.5	A
Input Voltage at Overcurrent Detection Pin	$V_{IN(IS)}$	- 0.3 to 4	V
Input Voltage at FB Pin	$V_{IN(FB)}$	4	V
Input Current at CS Pin	$I_{IN(CS)}$	2	mA
Total Power Dissipation($T_A = 25^\circ\text{C}$)	P_D	800	mW
Operating Temperature	T_{OPR}	- 25 to 85	$^\circ\text{C}$

ELECTRICAL CHARACTERISTICS

($V_{CC} = 18\text{V}$, $F_{OSC} = 135\text{KHz}$, $T_A = 25^\circ\text{C}$, unless otherwise specified)

Characteristic	Symbol	Test Conditions	Min	Typ	Max	Unit
OSCILLATOR SECTION						
Initial Accuracy	F_{OSC}	$C_T = 360\text{pF}$, $T_J = 25^\circ\text{C}$	125	135	145	KHz
Frequency Variation 1	$\Delta F/\Delta V$	$V_{CC} = 10\text{V to }30\text{V}$	—	± 1	± 3	%
Frequency Variation 2	$\Delta F/\Delta V$	$T_A = 25^\circ\text{C to }85^\circ\text{C}$	—	± 1.5	—	%
Ramp High Voltage	V_{RH}	$C_T = 360\text{pF}$, $T_J = 25^\circ\text{C}$	2.80	3.08	3.30	V
Ramp Low Voltage	V_{RL}	$C_T = 360\text{pF}$, $T_J = 25^\circ\text{C}$	0.6	0.9	1.2	V
Amplitude	V_{OSC}	V_{PIN7} , Peak to Peak	1.80	2.18	2.50	V
PULSE WIDTH MODULATION SECTION						
Input Threshold Voltage(Pin2)	$V_{TH(FBD)}$	Duty Cycle = 0%	0.6	0.75	0.95	V
Input Threshold Voltage(Pin2)	$V_{TH(FB1)}(\text{KA7552})$	Duty Cycle = Dmax 1	2.1	2.3	2.6	V
	$V_{TH(FB2)}(\text{KA7553})$	Duty Cycle = Dmax 2	1.6	1.8	2.1	V
Max. Duty Cycle	$D_{(\text{Max }1)}(\text{KA7552})$	—	66	70	74	%
	$D_{(\text{Max }2)}(\text{KA7553})$	—	43	46	49	%
Source Current(Pin2)	$I_{SOURCE(FB)}$	$V_{PIN2} = 0\text{V}$	- 660	- 800	- 960	μA

ELECTRICAL CHARACTERISTICS(Continued)

 (V_{CC} = 18V, F_{OSC} = 135Khz, T_A = 25°C, unless otherwise specified)

Characteristic	Symbol	Test Conditions	Min	Typ	Max	Unit
OVERCURRENT LIMIT SECTION						
Input Threshold Voltage	V _{TH(IS)}	—	0.21	0.24	0.27	V
Source Current(Pin3)	I _{SOURCE(IS)}	V _{PIN3} = 0V	-300	-200	-100	uA
Deley Time	T _D	—	—	150	—	ns
SOFT START SECTION						
Charging Current	I _{CHG}	V _{PIN8} = 0V	-15	-10	-5	uA
Input Threshold Voltage(Pin8)	V _{TH(CSO)}	Duty Cycle = Dmax 1	0.7	0.9	1.1	V
Input Threshold Voltage(Pin8)	V _{TH(CS1)(KA7552)}	Duty Cycle = Dmax 2	2.2	2.4	2.6	V
	V _{TH(CS2)(KA7553)}		1.7	1.9	2.1	V
LATCH MODE SHUTDOWN CIRCUIT SECTION						
Sink Current(Pin8)	I _{SINK(CS)}	V _{PIN8} = 6V, V _{PIN2} = 1V	25	45	65	uA
Shutdown Threshold Voltage	V _{TH(SD,CS)}	—	6.7	7.2	7.7	V
OVERLOAD SHUTDOWN SECTION						
Shudown Threshold Voltage	V _{TH(SD,FB)}	—	2.6	2.8	3.1	V
UNDER VOLTAGE LOCKOUT SECTION						
Start-Up Threshold Voltage	V _{TH(ST)}	—	15.5	16.0	16.5	V
Minimum Operating Voltage	V _{OPR(Min)}	—	8.20	8.70	9.20	V
Hysteresis	V _{HYS}	—	6.40	7.30	8.20	V
ON/OFF CONTROL SECTION						
Source Current(Pin8)	I _{SOURCE(CS)}	V _{PIN8} = 0V	- 15	- 10	- 5	uA
On Threshold Voltage	V _{TH(ON)}	V _{PIN8} : OFF->ON	0.45	0.56	0.70	V
Off Threshold Voltage	V _{TH(OFF)}	V _{PIN8} : ON-> OFF	0.30	0.42	0.55	V

ELECTRICAL CHARACTERISTICS(Continued)

 ($V_{CC} = 18V$, $F_{osc} = 135KHz$, $T_A = 25^{\circ}C$, unless otherwise specified)

Characteristic	Symbol	Test Conditions	Min	Typ	Max	Unit
OUTPUT SECTION						
Low Output Voltage	V_{OL}	$I_O = 100mA$, $V_{CC} = 18V$	—	1.3	1.8	V
High Output Voltage	V_{OH}	$I_O = -100mA$, $V_{CC} = 18V$	16.0	16.5	18.0	V
Rise Time	T_R	NO LOAD	—	50	—	ns
Fall Time	T_F	NO LOAD	—	50	—	ns
OVERALL						
Stand-by Current	I_{SB}	$V_{CC} = 14V$	—	90	150	μA
Operating Current	$I_{CC(OPR)}$	$V_{PIN2} = 0V$	—	9	15	mA
Power Supply Current off	$I_{CC(OFF)}$	$V_{PIN8} = 0V$	—	1.1	1.8	mA
Power Supply Current Shutdown	$I_{CC(SD)}$	$V_{PIN8} = 7.6V$	—	1.1	1.8	mA

* These parameters, although guaranteed, are not 100% tested in production.

NOTE : Recommend Operating Condition

 $R_T = 3.3K\Omega \sim 10K\Omega$, Oscillation Frequency = 5KHz ~ 600KHz

 Soft Start Condensor(CS) = 0.1 μF ~ 1 μF

Dimensions in Millimeters

