

5.8W AUDIO POWER AMPLIFIER.  
CAR STEREO, CAR RADIO OUTPUT.

#### FEATURES

- Output Power  
:  $P_{OUT}=5.8W$ (Typ.) at  $V_{CC}=13.2V$ ,  $R_L=4\Omega$ , THD=10%  
:  $P_{OUT}=9.2W$ (Typ.) at  $V_{CC}=13.2V$ ,  $R_L=2\Omega$ , THD=10%
- Maximum Output Power :  
:  $P_{OM}=9.5W$ (Typ.) at  $V_{CC}=13.2V$ ,  $R_L=4\Omega$
- Low Distortion : THD=0.15% at  $P_{OUT}=1W$ ,  $G_V=55dB$   
THD=0.07% at  $P_{OUT}=1W$ ,  $G_V=44dB$
- Wide Operating Supply Voltage Range :  $V_{CC}=9\sim 18V$
- Minimum Working Voltage : 9V
- Excessive Supply Voltage Protection Circuit.
- Current Limiting for Short Circuit Protection.
- Thermal Shut-down Circuit.

#### MAXIMUM RATINGS ( $T_a=25^\circ C$ )

CHARACTERISTIC	SYMBOL	RATING	UNIT
Operating Supply Voltage	$V_{CC}$	18	V
Quiescent Supply Voltage	$V_{CCQ}$	25	V
Output Current (Peak)	$I_{O(peak)}$	4.5	A
Power Dissipation	$P_D$	7.5	W
Operating Temperature	$T_{opr}$	-20~75	$^\circ C$
Storage Temperature	$T_{stg}$	-55~150	$^\circ C$

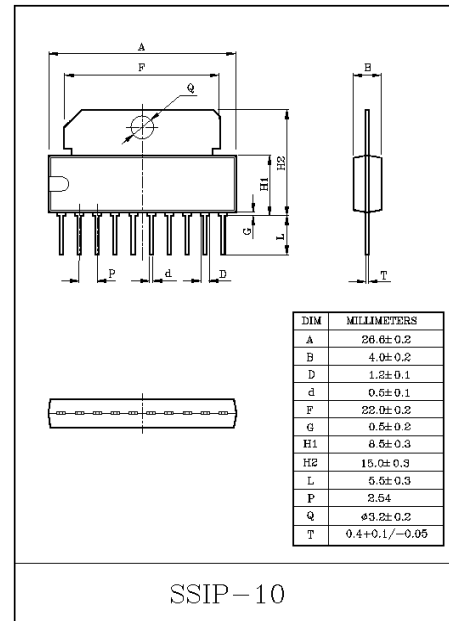

#### ELECTRICAL CHARACTERISTICS

(Unless otherwise specified.  $V_{CC}=12.5V$ ,  $R_L=4\Omega$ ,  $R_g=600\Omega$ ,  $R_f=82\Omega$ ,  $f=1kHz$ ,  $T_a=25^\circ C$ )

CHARACTERISTIC	SYMBOL	TEST CIRCUIT	TEST CONDITION	MIN.	TYP.	MAX.	UNIT
Quiescent Current	$I_{CCQ}$	-	-	-	-	60	mA
			$V_{CC}=18V$	-	-	80	
Output Power	$P_{OUT}$	-	THD=10%	4.5	5	-	W
			$V_{CC}=13.2V$ , THD=10%	-	5.8	-	
Maximum Output Voltage	$P_{OM}$	-	$V_{CC}=13.2V$	-	9.5	-	W
			$V_{CC}=13.2V$ , $R_L=2\Omega$ , THD=10%	-	9.2	-	
Total Harmonic Distortion	THD	-	$P_{OUT}=1W$	-	0.15	1.0	%
			$P_{OUT}=100mW$	-	0.2	1.0	
			$P_{OUT}=1W$ , $R_L=2\Omega$	-	0.25	1.0	
Voltage Gain (Note)	$G_V$	-	$V_{IN}=2.45mV_{rms}$	52	-	58	dB
Input Resistance	$R_{IN}$	-	$V_{OUT}=2V_{rms}$	30	40	-	k $\Omega$
Output Noise Voltage	$V_{NO}$	-	$R_g=10k\Omega$ , BW=50~20kHz	-	-	3.5	mV

Note : In regard to the value of voltage gain (closed loop voltage), it is possible to be classified.

# KIA7217AP

## EQUIVALENT CIRCUIT

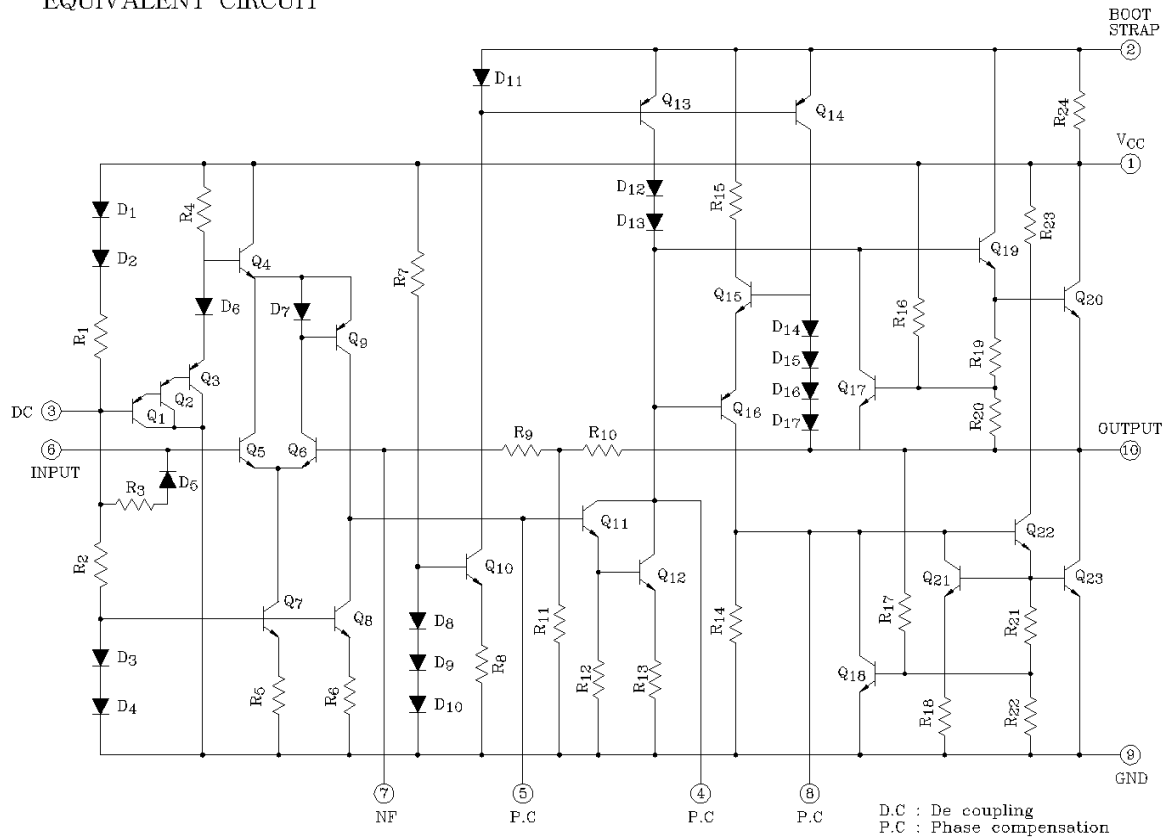

## TEST AND APPLICATION CIRCUIT

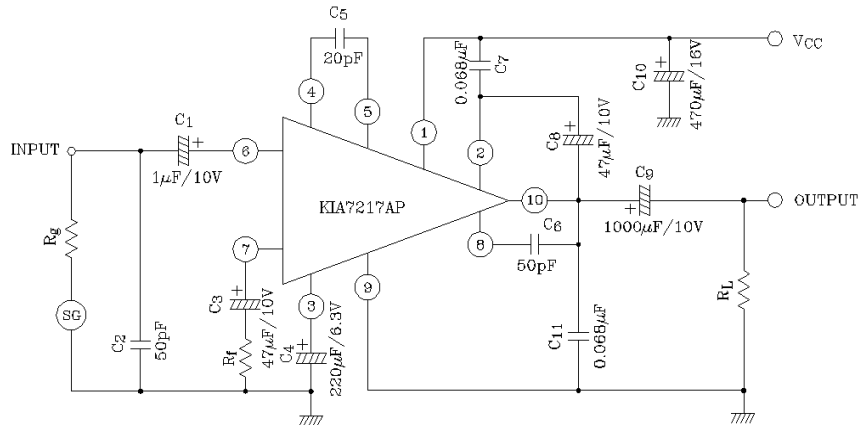

(Note) Metal Tab is connected to GND level or non-connection.  
C7 and C11 are polyester film capacitors.

# KIA7217AP

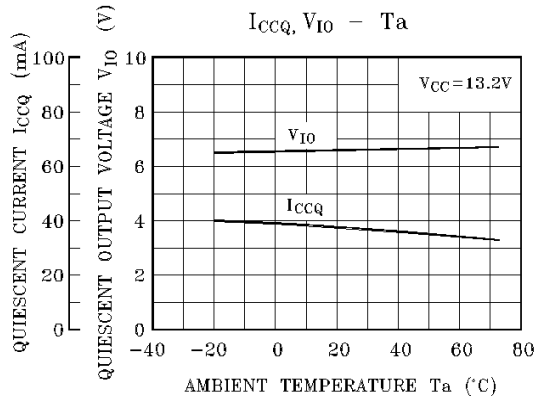
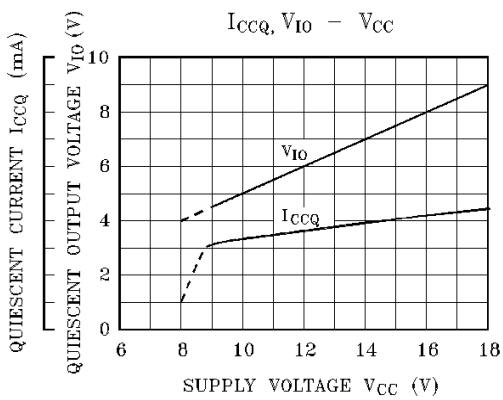
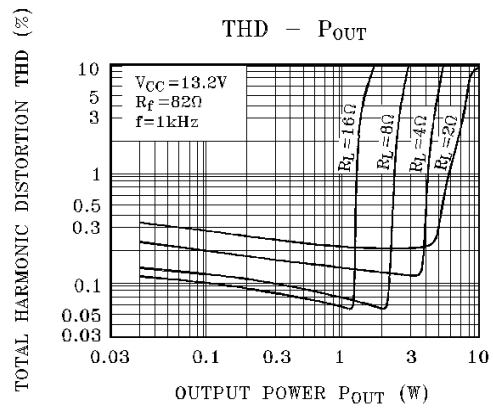
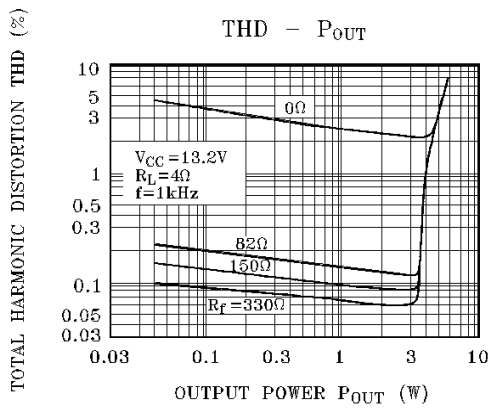
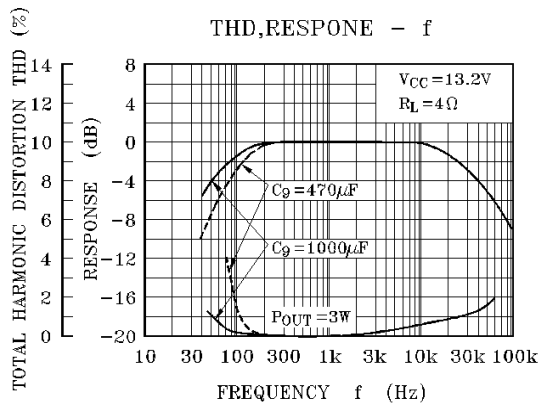
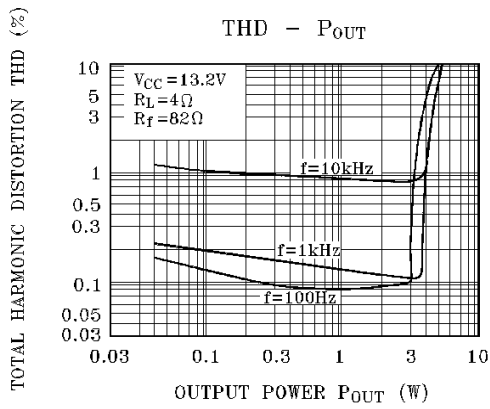

# KIA7217AP

