

**LA3600****5-Band Graphic Equalizer****Applications**

- Portable component stereos, tape-recorders, radio-cassette recorders, car stereos.

**Features**

- On-chip one operational amplifier.
- 5-band graphic equalizer for one channel can be formed easily by externally connecting capacitors and variable resistors which fix  $f_o$  (resonance frequency).
- Series connection of two LA3600's makes multiband (6 to 10 bands) available.
- Highly stable to capacitive load.

**Specifications****Absolute Maximum Ratings** at  $T_a = 25^\circ\text{C}$ 

Parameter	Symbol	Conditions	Ratings	Unit
Maximum Supply Voltage	$V_{CC \text{ max}}$		20	V
Allowable Power Dissipation	$P_d \text{ max}$		300	mW
Operating Temperature	$T_{opr}$		-20 to +75	$^\circ\text{C}$
Storage Temperature	$T_{stg}$		-40 to +125	$^\circ\text{C}$

**Operating Conditions** at  $T_a = 25^\circ\text{C}$ 

Parameter	Symbol	Conditions	Ratings	Unit
Recommended Supply Voltage	$V_{CC}$		8	V
Operating Voltage Range	$V_{CC \text{ op}}$		5 to 15	V

**Package Dimensions**

unit:mm

3006B-DIP16

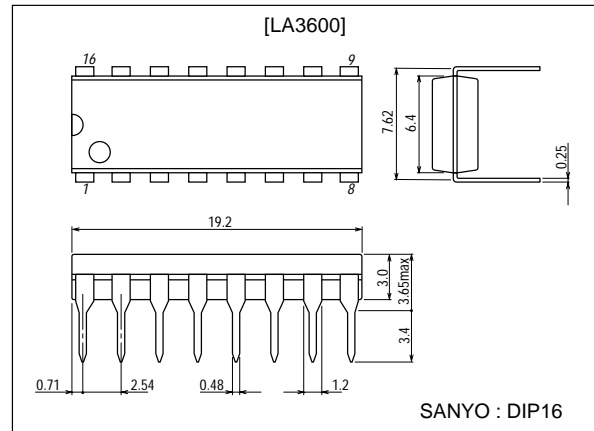

■ Any and all SANYO products described or contained herein do not have specifications that can handle applications that require extremely high levels of reliability, such as life-support systems, aircraft's control systems, or other applications whose failure can be reasonably expected to result in serious physical and/or material damage. Consult with your SANYO representative nearest you before using any SANYO products described or contained herein in such applications.

■ SANYO assumes no responsibility for equipment failures that result from using products at values that exceed, even momentarily, rated values (such as maximum ratings, operating condition ranges, or other parameters) listed in products specifications of any and all SANYO products described or contained herein.

**SANYO Electric Co.,Ltd. Semiconductor Company**

TOKYO OFFICE Tokyo Bldg., 1-10, 1 Chome, Ueno, Taito-ku, TOKYO, 110-8534 JAPAN

21000TH (KT)/33194HO/7297AT/8225MW/7274KI, TS No.1513-1/7

# LA3600

**Operating Characteristics** at  $T_a = 25^\circ\text{C}$ ,  $V_{CC}=8\text{V}$ ,  $R_L=10\text{k}\Omega$ ,  $R_g=600\Omega$ , See specified Test Circuit.

Parameter	Symbol	Conditions	Ratings			Unit
			min	typ	max	
Quiescent Current	$I_{CCO}$		3.0	5.0	8.0	mA
Voltage Gain	VG	$f=1\text{kHz}$ , $V_{in}=-10\text{dB}$ at all flat mode	-3.8	+0.8	+2.2	dB
Boost Amount	BOOST	$f=100\text{Hz}$	8	10	12	dB
		$f=340\text{Hz}$	8	10	12	dB
		$f=1\text{kHz}$	8	10	12	dB
		$f=3.4\text{kHz}$	8	10	12	dB
		$f=10\text{kHz}$	8	10	12	dB
Cut Amount	CUT	$f=100\text{Hz}$	-12	-10	-8	dB
		$f=340\text{Hz}$	-12	-10	-8	dB
		$f=1\text{kHz}$	-12	-10	-8	dB
		$f=3.4\text{kHz}$	-12	-10	-8	dB
		$f=10\text{kHz}$	-12	-10	-8	dB
Total Harmonic Distortion	THD	$f=1\text{kHz}$ , $V_o=1.0\text{V}$		0.03	0.1	%
Output Noise Voltage	$V_{NO}$	$R_g=0$ , All flat B.P.F. 10Hz to 30kHz		2.0	20	$\mu\text{V}$

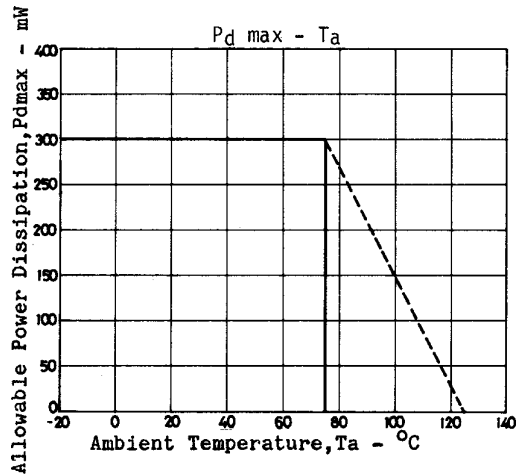

Test Method :  $V_{CC}=8\text{V}$ ,  $R_L=10\text{k}\Omega$ ,  $R_g=600\Omega$

Item	SW1	SW2	SW3	SW4	SW5	SW6	SW7	SW8	Conditions
$I_{CCO}$	1	-	-	-	-	-	2	1	
VG	2	F	F	F	F	F	1	1	$f=1\text{kHz}$ , $V_{in}=-10\text{dB}$
BOOST	2	B	F	F	F	F	1	1	$f=100\text{Hz}$
BOOST	2	F	B	F	F	F	1	1	$f=340\text{Hz}$
BOOST	2	F	F	B	F	F	1	1	$f=1\text{kHz}$
BOOST	2	F	F	F	B	F	1	1	$f=3.4\text{kHz}$
BOOST	2	F	F	F	F	B	1	1	$f=10\text{kHz}$
CUT	2	C	F	F	F	F	1	1	$f=100\text{Hz}$
CUT	2	F	C	F	F	F	1	1	$f=340\text{Hz}$
CUT	2	F	F	C	F	F	1	1	$f=1\text{kHz}$
CUT	2	F	F	F	C	F	1	1	$f=3.4\text{kHz}$
CUT	2	F	F	F	F	C	1	1	$f=10\text{kHz}$
THD	2	F	F	F	F	F	1	1	$f=1\text{kHz}$ , $V_o=1.0\text{V}$
$V_{NO}$	2	F	F	F	F	F	2	2	

# LA3600

## Test Circuit

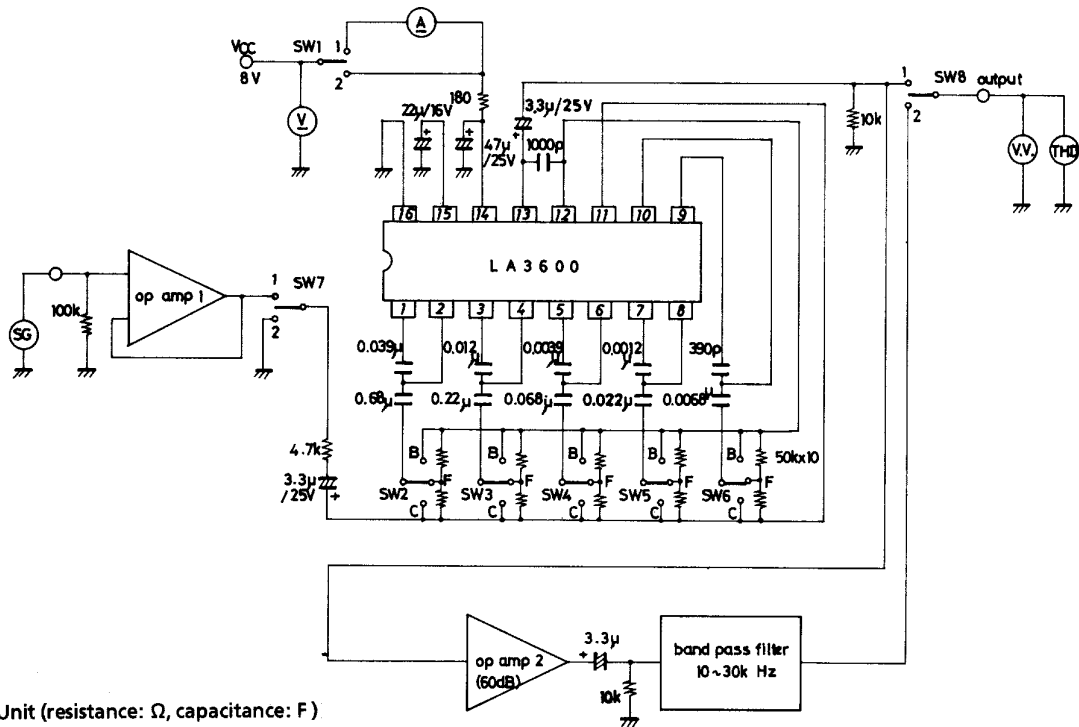

## Equivalent Circuit Block Diagram

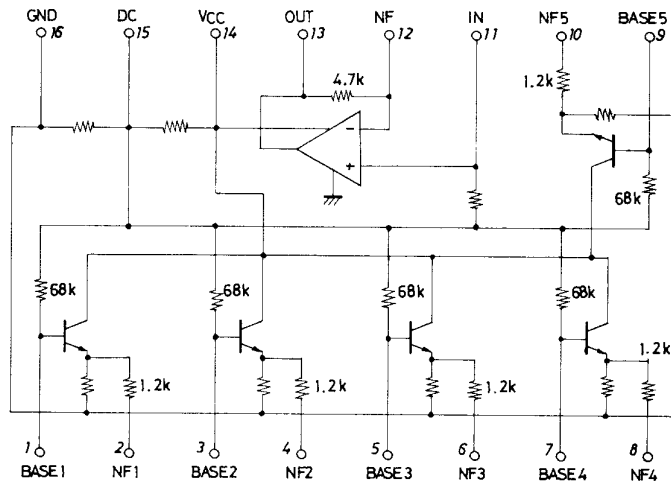

# LA3600

## Sample Application Circuit

Unit (resistance: Ω, capacitance: F)

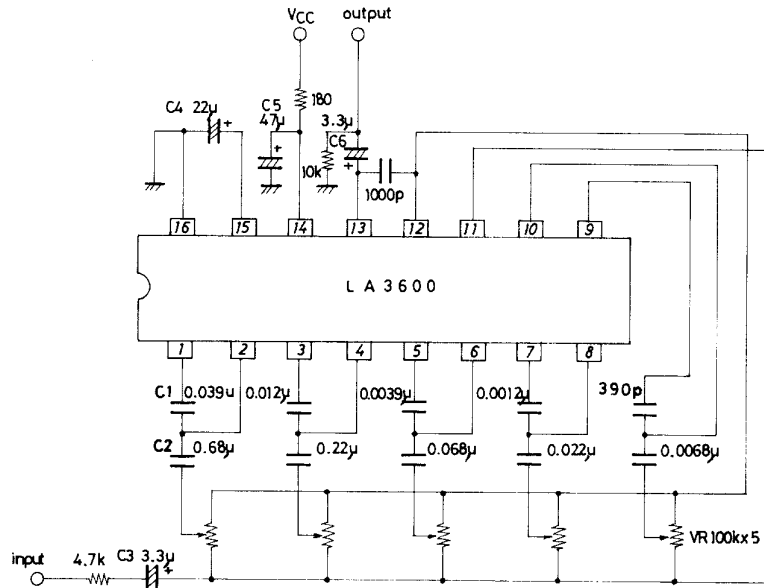

$f_0$  (resonance frequency)

In the sample application circuit,  $f_0$  for each of 5 bands is set as follows :

$f_0 = 108\text{Hz}, 343\text{kHz}, 1.08\text{kHz}, 3.43\text{kHz}, 10.8\text{kHz}$

$$f_0 = \frac{1}{2\pi \sqrt{C1, C2, R1, R2}} \quad (R1=1.2\text{k}\Omega, R2=68\text{k}\Omega \text{ on-chip resistor})$$

Description of external parts

C1, C2 : Capacitors used to fix  $f_0$  (resonance frequency)

C2 : Input capacitor. Decreasing the capacitor value lowers the frequency response at low frequencies.

C3 : Input capacitor. Decreasing the capacitor value lowers the frequency response at low frequencies.

C4 : Decoupling capacitor. Decreasing the capacitor value makes the effect of power supply stronger, whereby ripple is liable to occur.

C5 : Power capacitor.

C6 : Output capacitor. Decreasing the capacitor value lowers the frequency response at low frequencies.

# LA3600

## Sample Printed Circuit Pattern

Unit (resistance:  $\Omega$ , capacitance: F)

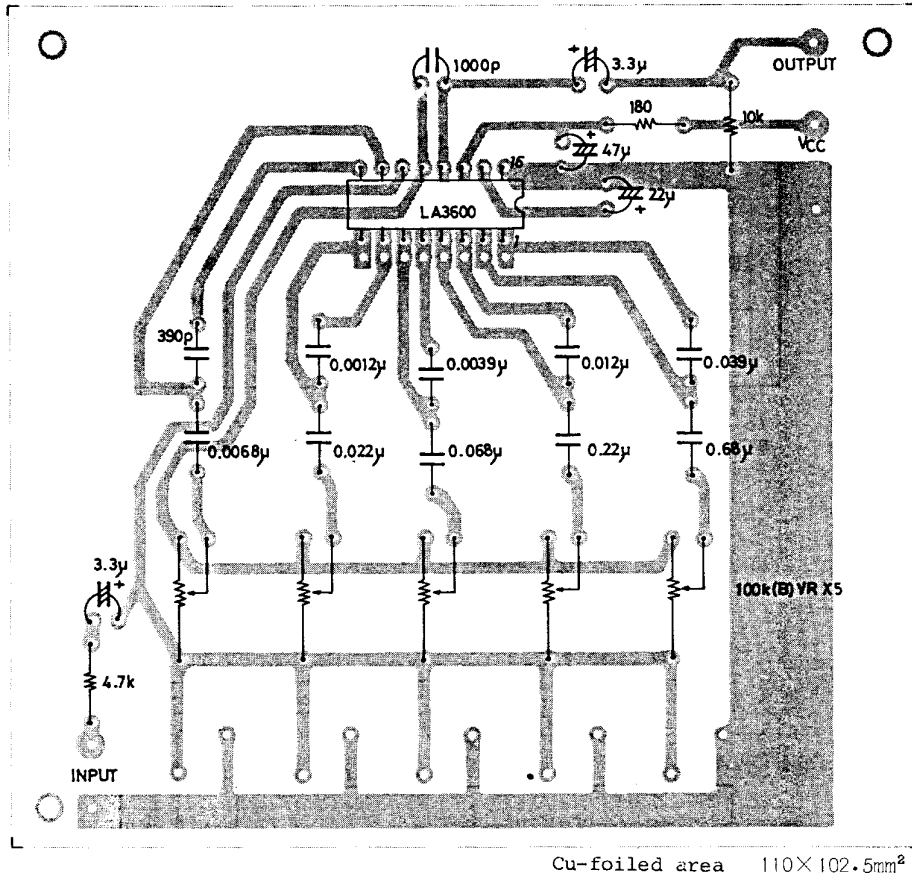

### Proper cares in using IC

- Maximum supply voltage  $V_{CC}$  max 20V must not be exceeded. The operating voltage is in the range of 5 to 15V.
- Application of power with the pin-to-pin spaces shorted causes breakdown or deterioration of the IC to occur. When mounting the IC on the board or applying power, make sure that the pin-to-pin spaces are not shorted with solder, etc.

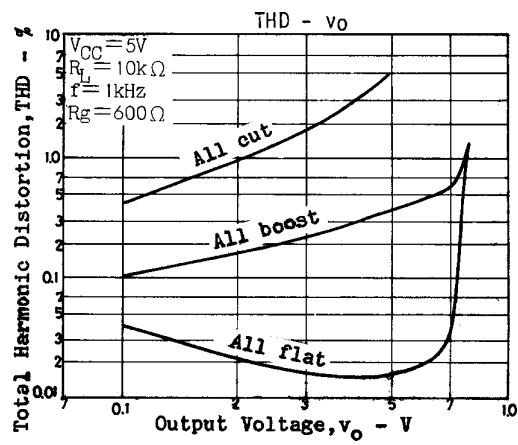
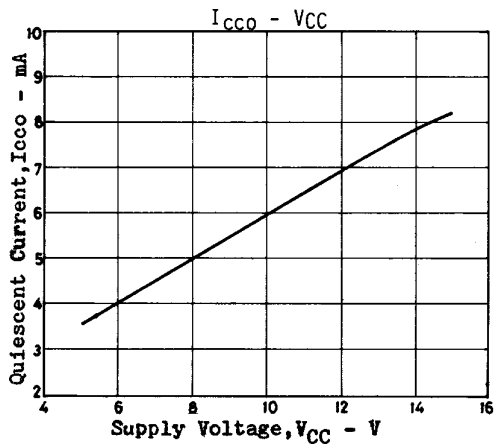

# LA3600

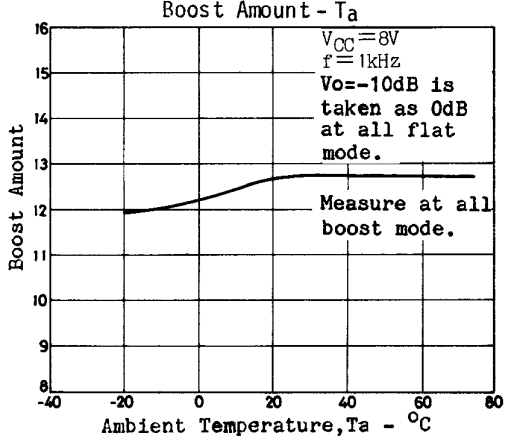
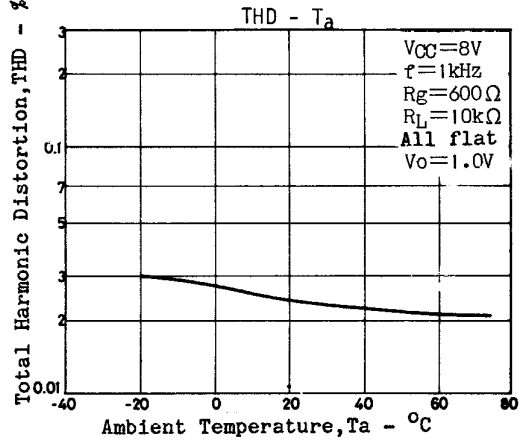
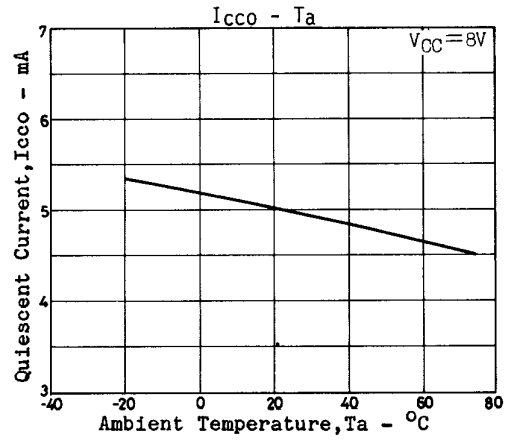
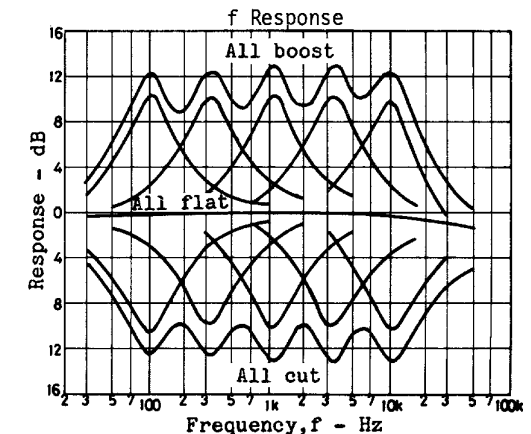
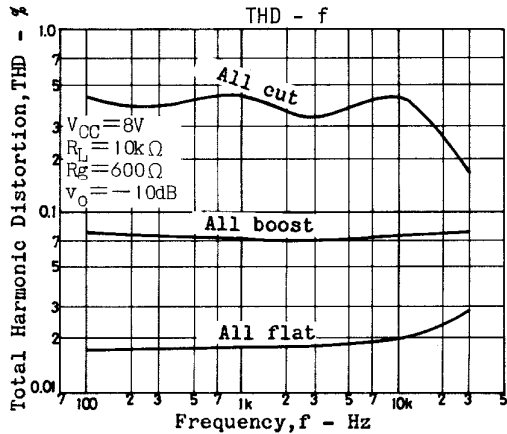
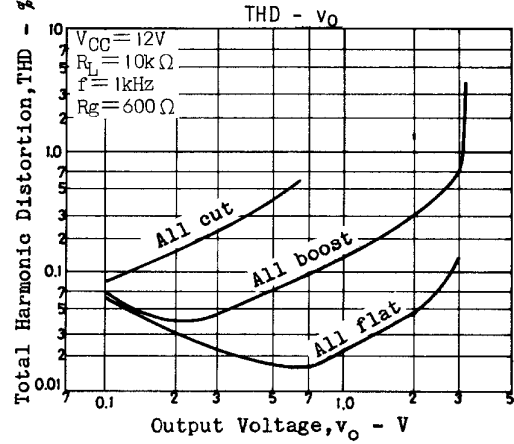
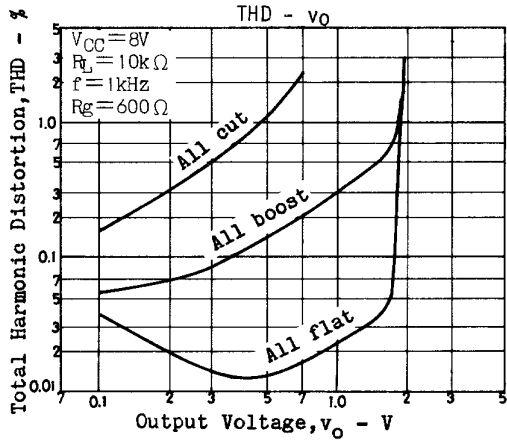

- Specifications of any and all SANYO products described or contained herein stipulate the performance, characteristics, and functions of the described products in the independent state, and are not guarantees of the performance, characteristics, and functions of the described products as mounted in the customer's products or equipment. To verify symptoms and states that cannot be evaluated in an independent device, the customer should always evaluate and test devices mounted in the customer's products or equipment.
- SANYO Electric Co., Ltd. strives to supply high-quality high-reliability products. However, any and all semiconductor products fail with some probability. It is possible that these probabilistic failures could give rise to accidents or events that could endanger human lives, that could give rise to smoke or fire, or that could cause damage to other property. When designing equipment, adopt safety measures so that these kinds of accidents or events cannot occur. Such measures include but are not limited to protective circuits and error prevention circuits for safe design, redundant design, and structural design.
- In the event that any or all SANYO products(including technical data, services) described or contained herein are controlled under any of applicable local export control laws and regulations, such products must not be exported without obtaining the export license from the authorities concerned in accordance with the above law.
- No part of this publication may be reproduced or transmitted in any form or by any means, electronic or mechanical, including photocopying and recording, or any information storage or retrieval system, or otherwise, without the prior written permission of SANYO Electric Co., Ltd.
- Any and all information described or contained herein are subject to change without notice due to product/technology improvement, etc. When designing equipment, refer to the "Delivery Specification" for the SANYO product that you intend to use.
- Information (including circuit diagrams and circuit parameters) herein is for example only ; it is not guaranteed for volume production. SANYO believes information herein is accurate and reliable, but no guarantees are made or implied regarding its use or any infringements of intellectual property rights or other rights of third parties.

This catalog provides information as of February, 2000. Specifications and information herein are subject to change without notice.