



# LA2000

## Audio Level Sensor

### Overview

LA2000 is an IC for detecting interprogram spaces to pick out the starting point of a program immediately preceding or following a musical program recorded on tape, and to detect end of tape.

### Used in

- Radio-cassette recorders
- Cassette decks
- Car stereos

### Applications

- Detection of spaces between programs recorded on tape
- Detection of end of tape
- Other

### Features

- Has transistors capable of driving plungers with maximum 600 mA, and a protective diode to prevent induced reverse voltages.
- Can provide designated time delays by externally connected capacitors and resistors.
- Has a comparator with stable hysteresis to handle variations in power supply voltage.
- Detects unrecorded portions of tape.

### Package Dimensions

unit : mm

#### 3017B-SIP9

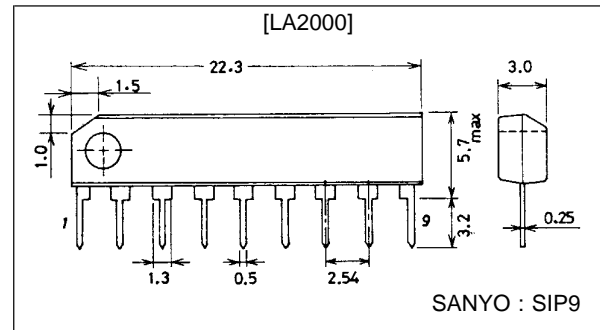

### Specifications

#### Maximum Ratings at $T_a = 25\text{ }^\circ\text{C}$

Parameter	Symbol	Conditions	Ratings	Unit
Maximum supply voltage	$V_{CC\text{ max}}$		15	V
Allowable power dissipation	$P_d\text{ max}$		540	mW
Flow-in current	$I_g\text{ max}$		600	mA
Operating temperature	$T_{opr}$		-20 to +75	$^\circ\text{C}$
Storage temperature	$T_{stg}$		-40 to +125	$^\circ\text{C}$

- Note: 1. The voltage at pin 8 must not exceed the supply voltage at pin 9.  
 2. The maximum current flowing into pin 8 should be no greater than 0.5 mA.

■ Any and all SANYO products described or contained herein do not have specifications that can handle applications that require extremely high levels of reliability, such as life-support systems, aircraft's control systems, or other applications whose failure can be reasonably expected to result in serious physical and/or material damage. Consult with your SANYO representative nearest you before using any SANYO products described or contained herein in such applications.

■ SANYO assumes no responsibility for equipment failures that result from using products at values that exceed, even momentarily, rated values (such as maximum ratings, operating condition ranges, or other parameters) listed in products specifications of any and all SANYO products described or contained herein.

**SANYO Electric Co.,Ltd. Semiconductor Business Headquarters**

TOKYO OFFICE Tokyo Bldg., 1-10, 1 Chome, Ueno, Taïto-ku, TOKYO, 110-8534 JAPAN

53096HA(II)/0267KI/5085MW/MW No.982-1/8

# LA2000

## Operating Conditions at $T_a = 25^\circ\text{C}$

Parameter	Symbol	Conditions	Ratings	Unit
Operating voltage range	$V_{CC\ op}$		3.5 to 14	V

## Electrical Characteristics at $T_a = 25^\circ\text{C}$ , $V_{CC} = 9.0\text{ V}$ , $f = 1\text{ kHz}$

Parameter	Symbol	Conditions	min	typ	max	Unit
Circuit current	$I_{CC}$	$f = 1\text{ kHz}$ , $V_{IN} = -45\text{ dB}$		6	12	mA
Output transistor saturating voltage	$V_{CE\ (sat)}$	$I_6 = 600\text{ mA}$		1.5	2.5	V
Output diode forward voltage	$V_F$	$I_F = 600\text{ mA}$		1.5	2.0	V
Output-off level in input equivalent	$V_{IN}$	$f = 1\text{ kHz}$	-43	-50	-54	dBm
Comparator-on level	$V_{TH-H}$		3.0	3.5	4.0	V
Comparator-off level	$V_{TH-L}$		1.8	2.2	2.6	V
Pin 8 high level	$V_8\ \text{pin}$		0.45	0.55		V
Output transistor leakage current	$I_{L-TR}$				100	$\mu\text{A}$
Output diode leakage current	$I_{L-Di}$				100	$\mu\text{A}$

### 1. Description of external parts

C1	Input coupling capacitor	0.47 to 2.2 $\mu\text{F}$ recommended.
C2	NF capacitor	Capacitance is reduced, so the off level in input equivalent becomes lower in the bass frequency range. We recommend 1 to 10 $\mu\text{F}$ .
C3, R1	For designation of time delays	Any time delay can be obtained by adequate choice of C3 and R1. We recommend 150 k to 500 k $\Omega$ for R1.
C4, R3	Power supply ripple filter	
R2	Bias resistor	For diode when pin 8 is used to drive external transistors. A 1 k $\Omega$ resistor is recommended.

### 2. Individual pins and their operations

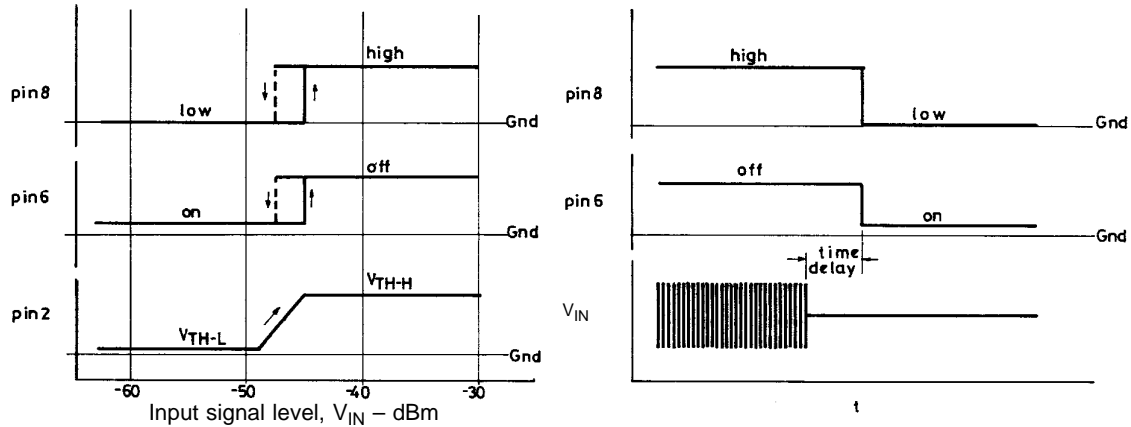

As shown above, when input level is raised and the pin 2 voltage reaches the  $V_{TH-H}$  level of the comparator, pins 6 and 8 turn over. ( $V_{IN} = -45\text{ dBm}$ ).

- Pin 6 is for driving plungers, When it is on the "L" side, pin 6 turns on and can draw current up to 600 mA maximum (restricted by duty-cycle chart). It is not to be on continuously for more than 3 seconds.
- Pin 7 is a diode that prevents reverse voltages induced when the plunger is turned off from on.
- Pin 8 functions in phase with pin 6 and can drive external transistors (such as for MUTE).

## LA2000

### 3. Time delays and obtaining CRs

When input signals that have been applied at a level not less than -45 dBm are removed, discharging occurs through the CR connected at pin 2, lowering pin 2 potential. A time delay is provided before the hysteresis comparator turns over.

$$\frac{E1}{E0} = - \frac{t}{e^{\tau}}$$

E0 : Initial voltage  
E1 : Threshold voltage  
 $\tau$  : Time constant

Accordingly,

$$t = -\tau \ln \frac{E1}{E0}$$

E1/E0, within the IC, is 0.26. A desired time is obtained by an appropriate choice of  $\tau$  ( $\tau = C3R1$ ). Therefore, the time delay is obtained by the following formula:

$$t = 1.34 \times C3R1 \text{ (sec)}$$

We recommend 150 k to 500 k $\Omega$  for R when determining CR.

### 4. IC usage notes

- Maximum ratings

When maximum ratings are surpassed, destruction or deterioration may result. Use the IC in the range where the maximum rating is not exceeded.

- Interpin short circuits and reverse insertions

These cause destruction or deterioration of the IC: be careful when mounting on circuit board.

- Voltage applied to pin 8 should never exceed pin 9 voltage.

- The current flowing into pin 8 is to be 0.5 mA maximum.

- Pin 4 is unconnected, but is not to be used for GND or an interconnecting terminal.

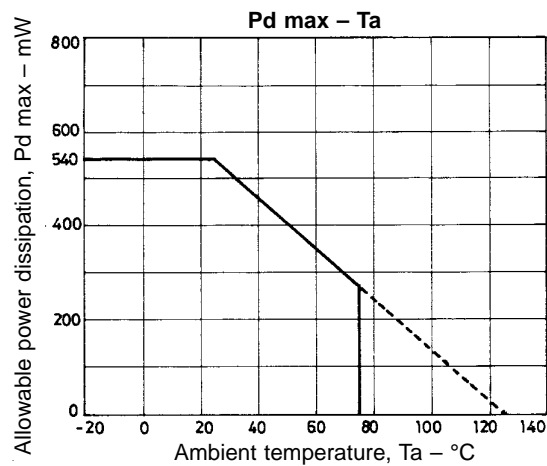
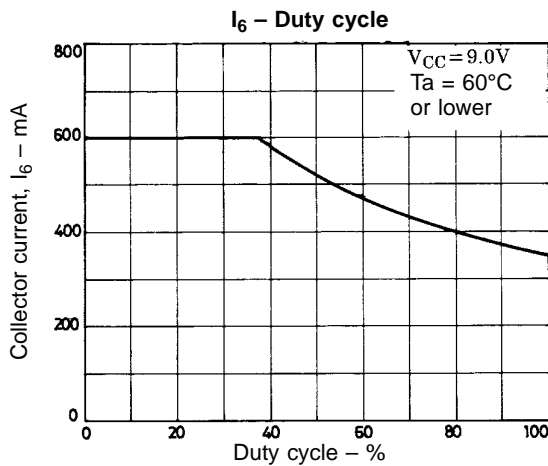

Note: I<sub>C</sub> = 600 mA continuous is within 3 seconds  
I<sub>C</sub> = 300 mA continuous is within 30 seconds  
I<sub>C</sub> = 100 mA or less can be left on at all times.

# LA2000

## Test Circuit

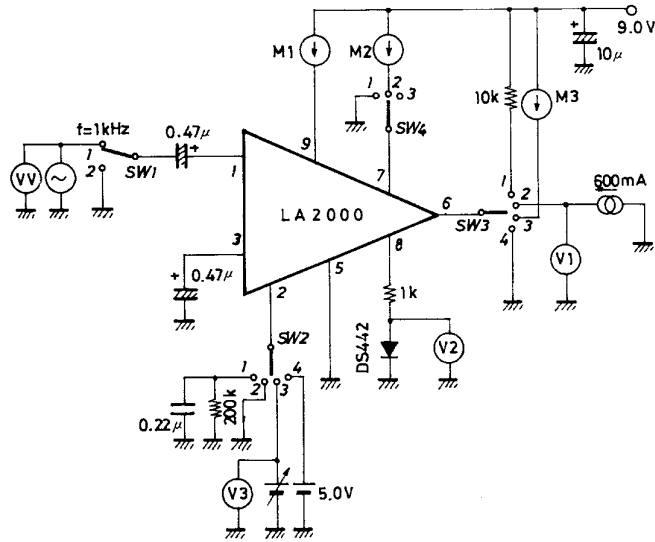

Unit (resistance:  $\Omega$ , capacitance: F)

## Test Conditions

Test items	Symbol	SW-1	SW-2	SW-3	SW-4	Conditions
Circuit current	$I_{CC}$	1	1	1	3	Measure current flowing into pin 9 at $V_{IN} = -45$ dB
Output transistor saturation voltage	$V_{CE}(\text{sat})$	2	2	2	3	Measure $V_{IN}$ at pin 6
Output diode forward voltage	$V_F$	2	4	2	1	Measure $V_{IN}$ at pin 6
Output-off level in input equivalent	$V_{IN}$	1	1	1	3	Input level (V.V) when pin 6 turns over
Comparator-on level	$V_H$	2	3	1	3	Measure V3 When pin 6 turns over
Comparator-off level	$V_L$	2	3	1	3	Measure V3 When pin 6 turns over
Pin 8 high level	$V_{p-8}$	2	4	1	3	Measure V2 at pin 8
Output transistor leakage current	$I_{TL}$	2	4	3	3	Measure M3
Output diode leakage current	$I_{DL}$	2	4	4	2	Measure M2

## Equivalent Circuit Block Diagram

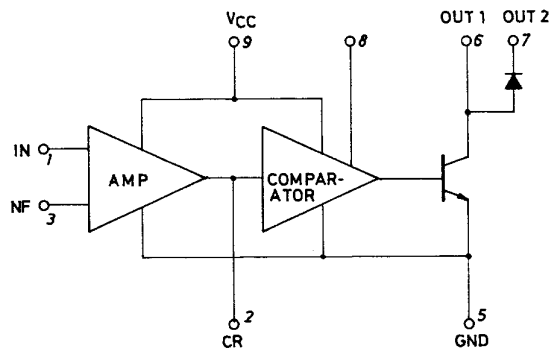

# LA2000

## Sample Application Circuit 1

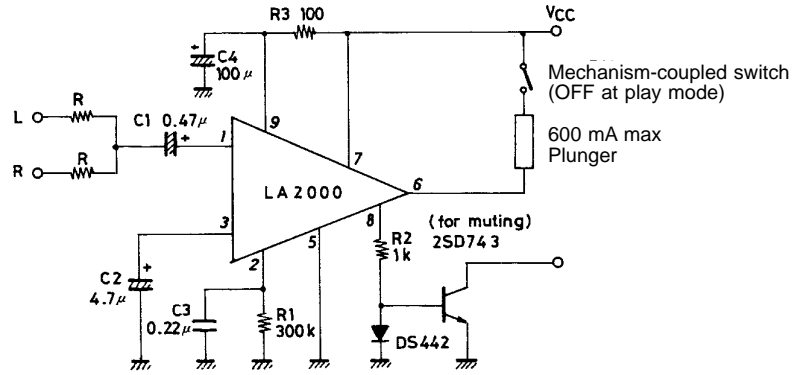

Unit (resistance:  $\Omega$ , capacitance: F)

Pin 4 is unconnected but is not be used for GND or an interconnection terminal.

## Sample Printed Pattern (copper foil side)

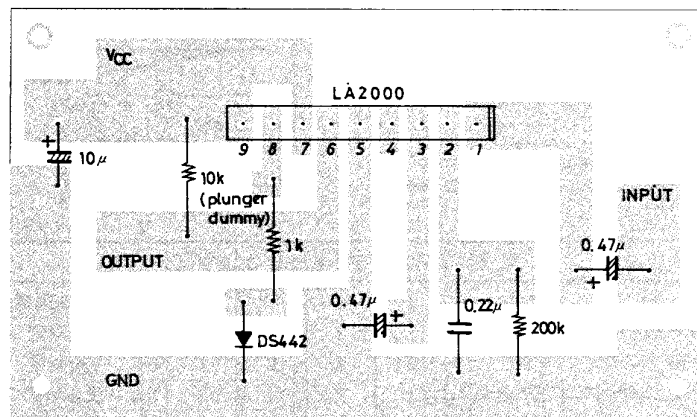

Unit (resistance:  $\Omega$ , capacitance: F)

# LA2000

## Sample Application Circuit 2

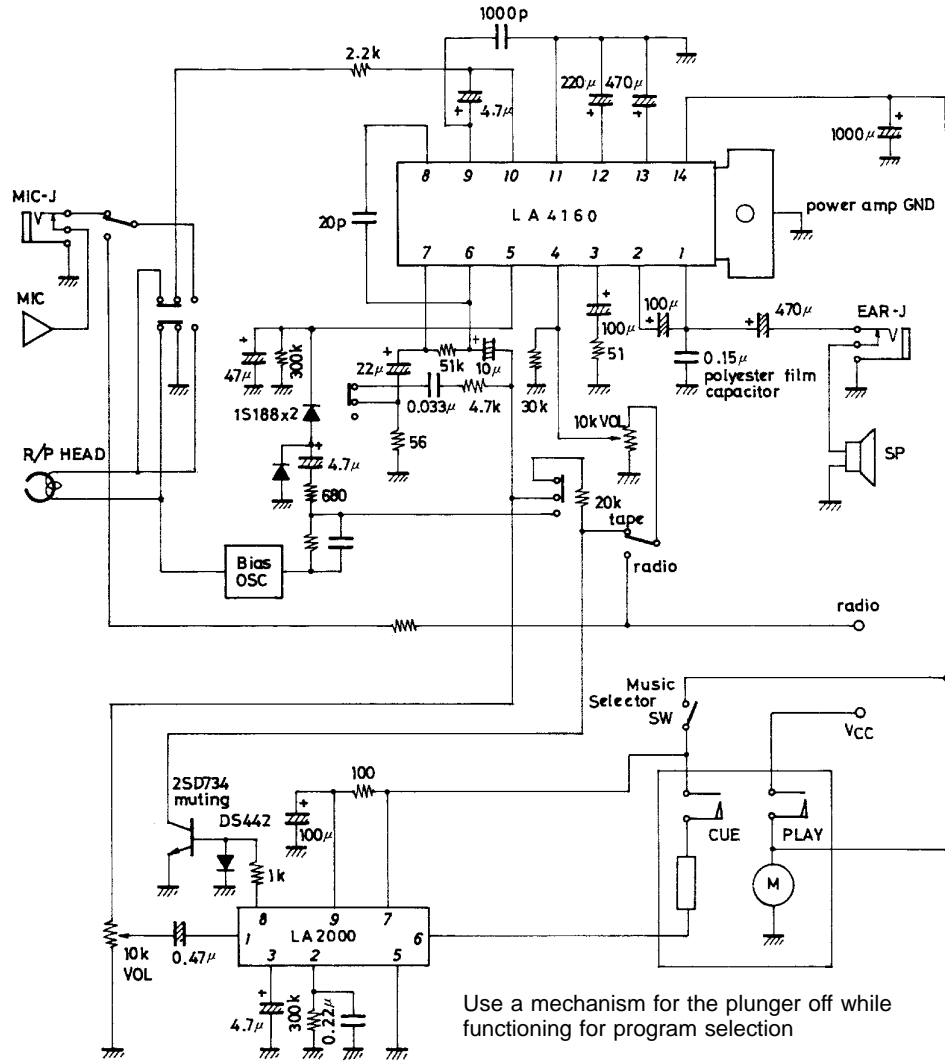

Use a mechanism for the plunger off while functioning for program selection

Unit (resistance:  $\Omega$ , capacitance: F)

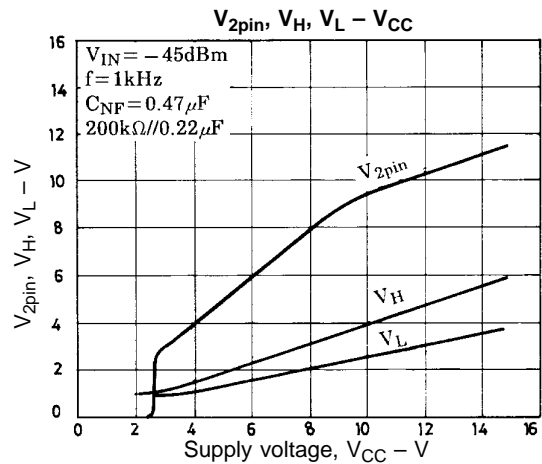
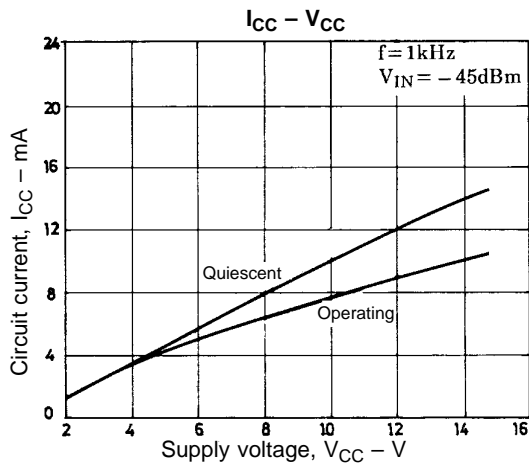

# LA2000

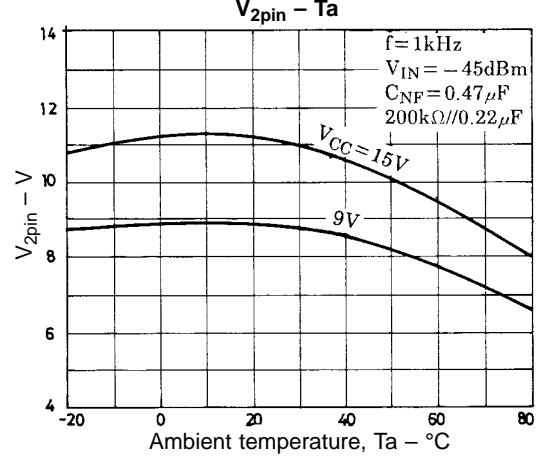
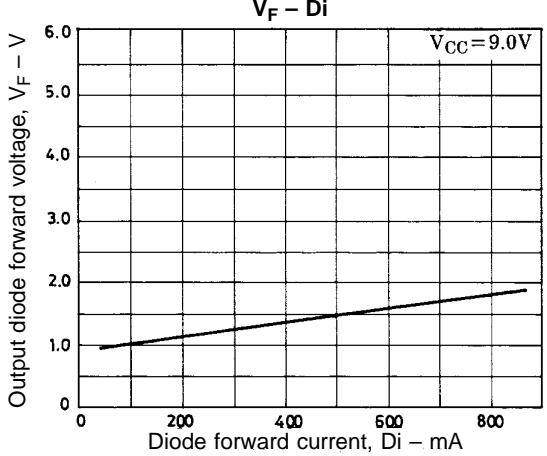
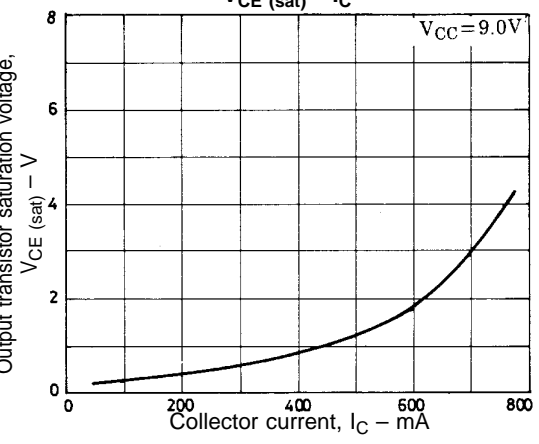
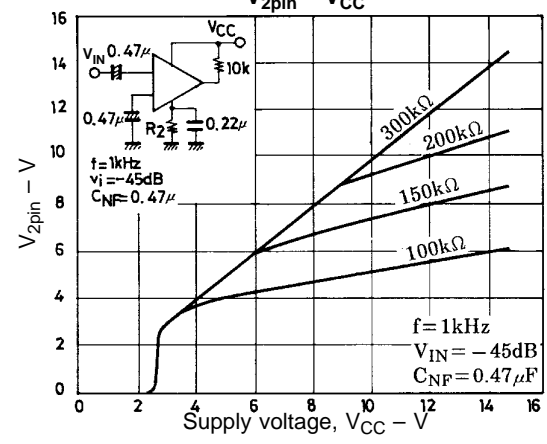
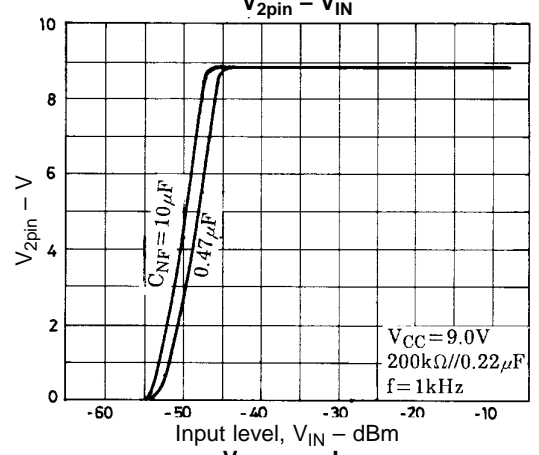
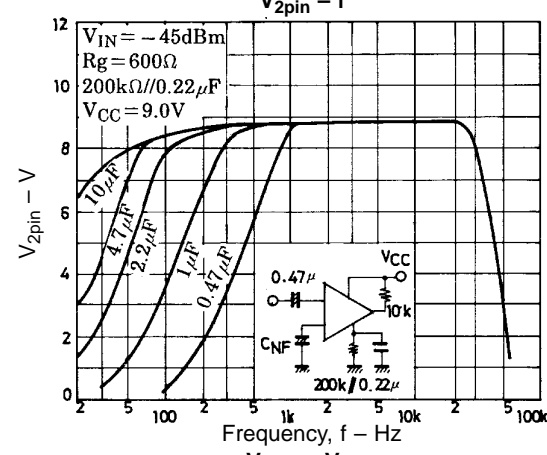
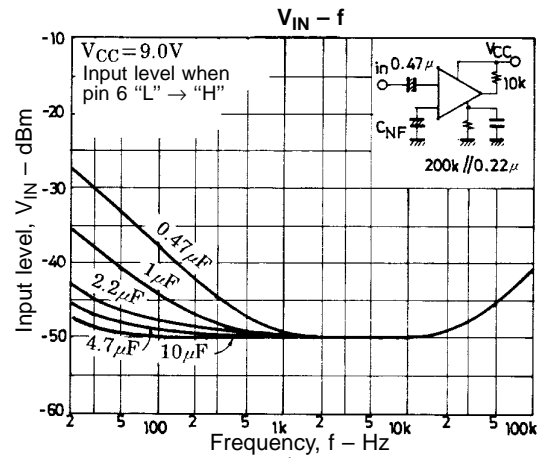
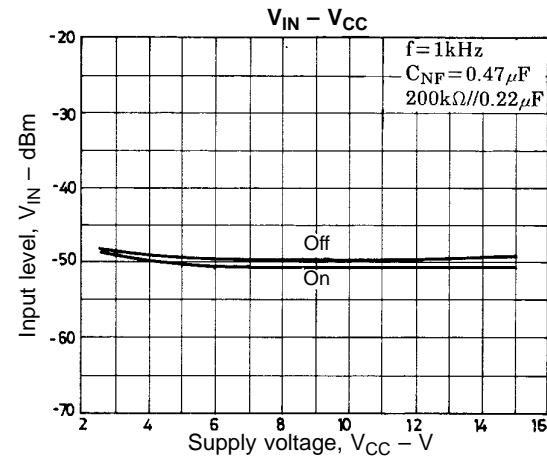

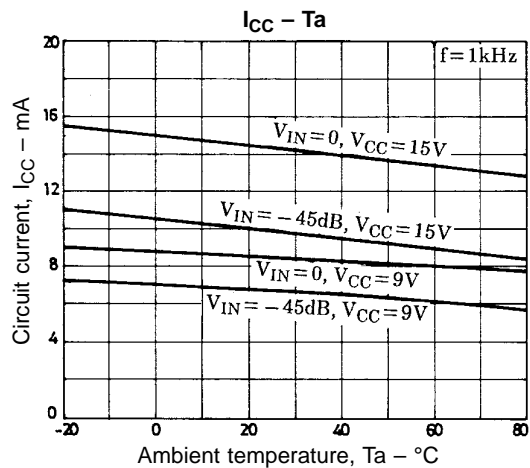
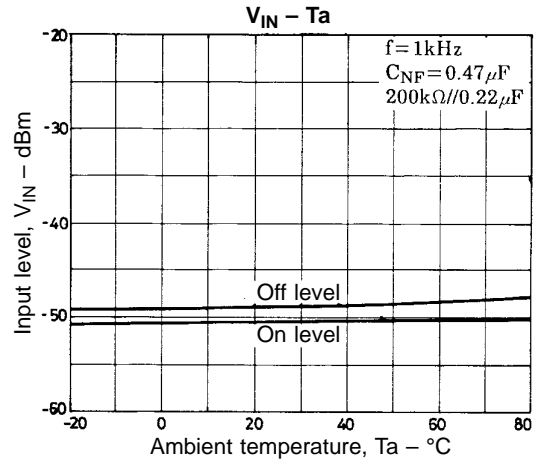
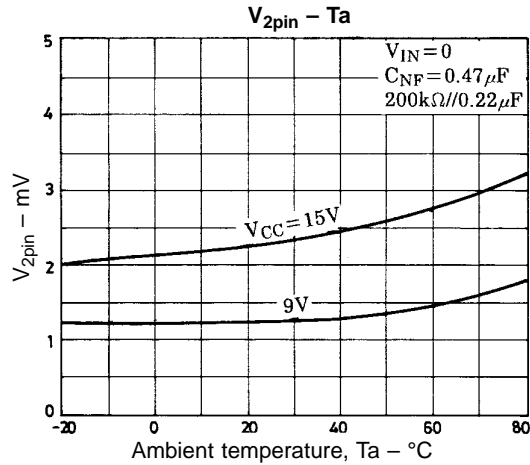

- Specifications of any and all SANYO products described or contained herein stipulate the performance, characteristics, and functions of the described products in the independent state, and are not guarantees of the performance, characteristics, and functions of the described products as mounted in the customer's products or equipment. To verify symptoms and states that cannot be evaluated in an independent device, the customer should always evaluate and test devices mounted in the customer's products or equipment.
- SANYO Electric Co., Ltd. strives to supply high-quality high-reliability products. However, any and all semiconductor products fail with some probability. It is possible that these probabilistic failures could give rise to accidents or events that could endanger human lives, that could give rise to smoke or fire, or that could cause damage to other property. When designing equipment, adopt safety measures so that these kinds of accidents or events cannot occur. Such measures include but are not limited to protective circuits and error prevention circuits for safe design, redundant design, and structural design.
- In the event that any or all SANYO products (including technical data, services) described or contained herein are controlled under any of applicable local export control laws and regulations, such products must not be exported without obtaining the export license from the authorities concerned in accordance with the above law.
- No part of this publication may be reproduced or transmitted in any form or by any means, electronic or mechanical, including photocopying and recording, or any information storage or retrieval system, or otherwise, without the prior written permission of SANYO Electric Co., Ltd.
- Any and all information described or contained herein are subject to change without notice due to product/technology improvement, etc. When designing equipment, refer to the "Delivery Specification" for the SANYO product that you intend to use.
- Information (including circuit diagrams and circuit parameters) herein is for example only; it is not guaranteed for volume production. SANYO believes information herein is accurate and reliable, but no guarantees are made or implied regarding its use or any infringements of intellectual property rights or other rights of third parties.

This catalog provides information as of May, 1996. Specifications and information herein are subject to change without notice.