

DM7476

Dual Master-Slave J-K Flip-Flops with Clear, Preset, and Complementary Outputs

General Description

This device contains two independent positive pulse triggered J-K flip-flops with complementary outputs. The J and K data is processed by the flip-flop after a complete clock pulse. While the clock is low the slave is isolated from the master. On the positive transition of the clock, the data from the J and K inputs is transferred to the master. While the clock is high the J and K inputs are disabled. On the negative transition of the clock, the data from the master is transferred to the slave. The logic state of J and K inputs must not be al-

lowed to change while the clock is high. The data is transferred to the outputs on the falling edge of the clock pulse. A low logic level on the preset or clear inputs will set or reset the outputs regardless of the logic levels of the other inputs.

Features

- Alternate Military/Aerospace device (5476) is available. Contact a Fairchild Semiconductor Sales Office/Distributor for specifications.

Connection Diagram

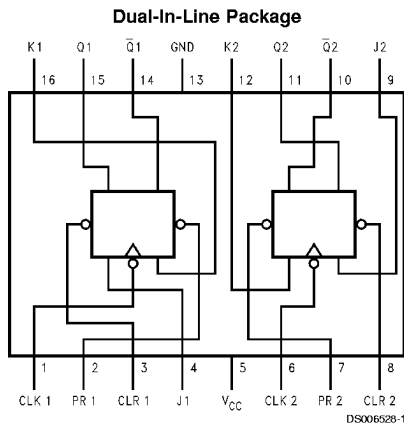

Order Number 5476DMQB, 5476FMQB,
DM5476J, DM5476W or DM7476N
See Package Number J16A, N16E or W16A

Function Table

Inputs					Outputs	
PR	CLR	CLK	J	K	Q	\bar{Q}
L	H	X	X	X	H	L
H	L	X	X	X	L	H
L	L	X	X	X	H	H
H	H	\neg	L	L	(Note 1) Q_0	(Note 1) \bar{Q}_0
H	H	\neg	H	L	H	L
H	H	\neg	L	H	L	H
H	H	\neg	H	H	Toggle	

H = High Logic Level
L = Low Logic Level
X = Either Low or High Logic Level
 \neg = Positive pulse data. The J and K inputs must be held constant while the clock is high. Data is transferred to the outputs on the falling edge of the clock pulse.
 Q_0 = The output logic level before the indicated input conditions were established.
Toggle = Each output changes to the complement of its previous level on each complete active high level clock pulse.
Note 1: This configuration is nonstable; that is, it will not persist when the preset and/or clear inputs return to their inactive (high) level.

DM7476 Dual Master-Slave J-K Flip-Flops with Clear, Preset, and Complementary Outputs

Absolute Maximum Ratings (Note 2)

Supply Voltage	7V	DM54 and 54	-55°C to +125°C
Input Voltage	5.5V	DM74	0°C to +70°C
Operating Free Air Temperature Range		Storage Temperature Range	-65°C to +150°C

Recommended Operating Conditions

Symbol	Parameter	DM5476			DM7476			Units
		Min	Nom	Max	Min	Nom	Max	
V _{CC}	Supply Voltage	4.5	5	5.5	4.75	5	5.25	V
V _{IH}	High Level Input Voltage	2			2			V
V _{IL}	Low Level Input Voltage			0.8			0.8	V
I _{OH}	High Level Output Current			-0.4			-0.4	mA
I _{OL}	Low Level Output Current			16			16	mA
f _{CLK}	Clock Frequency (Note 8)	0		15	0		15	MHz
t _w	Pulse Width (Note 8)	Clock High	20		20			ns
		Clock Low	47		47			
		Preset Low	25		25			
		Clear Low	25		25			
t _{SU}	Input Setup Time (Notes 3, 8)	0↑			0↑			ns
t _H	Input Hold Time (Notes 3, 8)	0↓			0↓			ns
T _A	Free Air Operating Temperature	-55		125	0		70	°C

Note 2: The "Absolute Maximum Ratings" are those values beyond which the safety of the device cannot be guaranteed. The device should not be operated at these limits. The parametric values defined in the "Electrical Characteristics" table are not guaranteed at the absolute maximum ratings. The "Recommended Operating Conditions" table will define the conditions for actual device operation.

Electrical Characteristics

over recommended operating free air temperature range (unless otherwise noted)

Symbol	Parameter	Conditions	Min	Typ (Note 4)	Max	Units
V _I	Input Clamp Voltage	V _{CC} = Min, I _I = -12 mA			-1.5	V
V _{OH}	High Level Output Voltage	V _{CC} = Min, I _{OH} = Max V _{IL} = Max, V _{IH} = Min	2.4	3.4		V
V _{OL}	Low Level Output Voltage	V _{CC} = Min, I _{OL} = Max V _{IH} = Min, V _{IL} = Max		0.2	0.4	V
I _I	Input Current @ Max Input Voltage	V _{CC} = Max, V _I = 5.5V			1	mA
I _{IH}	High Level Input Current	V _{CC} = Max V _I = 2.4V	J, K		40	μA
			Clock		80	
			Clear		80	
			Preset		80	
I _{IL}	Low Level Input Current	V _{CC} = Max V _I = 0.4V (Note 7)	J, K		-1.6	mA
			Clock		-3.2	
			Clear		-3.2	
			Preset		-3.2	
I _{OS}	Short Circuit Output Current	V _{CC} = Max (Note 5)	DM54		-20	mA
			DM74		-18	
I _{CC}	Supply Current	V _{CC} = Max (Note 6)		18	34	mA

Note 3: The symbol (↑, ↓) indicates the edge of the clock pulse is used for reference (↑) for rising edge, (↓) for falling edge.

Note 4: All typicals are at V_{CC} = 5V, T_A = 25°C.

Note 5: Not more than one output should be shorted at a time.

Note 6: With all outputs open, I_{CC} is measured with the Q and \bar{Q} outputs high in turn. At the time of measurement the clock input is grounded.

Note 7: Clear is measured with preset high and preset is measured with clear high.

Electrical Characteristics (Continued)

Note 8: $T_A = 25^\circ\text{C}$ and $V_{CC} = 5\text{V}$.

Switching Characteristics

at $V_{CC} = 5\text{V}$ and $T_A = 25^\circ\text{C}$

Symbol	Parameter	From (Input) To (Output)	$R_L = 400\Omega$ $C_L = 15\text{ pF}$		Units
			Min	Max	
f_{MAX}	Maximum Clock Frequency		15		MHz
t_{PHL}	Propagation Delay Time High to Low Level Output	Preset to \bar{Q}		40	ns
t_{PLH}	Propagation Delay Time Low to High Level Output	Preset to Q		25	ns
t_{PHL}	Propagation Delay Time High to Low Level Output	Clear to Q		40	ns
t_{PLH}	Propagation Delay Time Low to High Level Output	Clear to \bar{Q}		25	ns
t_{PHL}	Propagation Delay Time High to Low Level Output	Clock to Q or \bar{Q}		40	ns
t_{PLH}	Propagation Delay Time Low to High Level Output	Clock to Q or \bar{Q}		25	ns

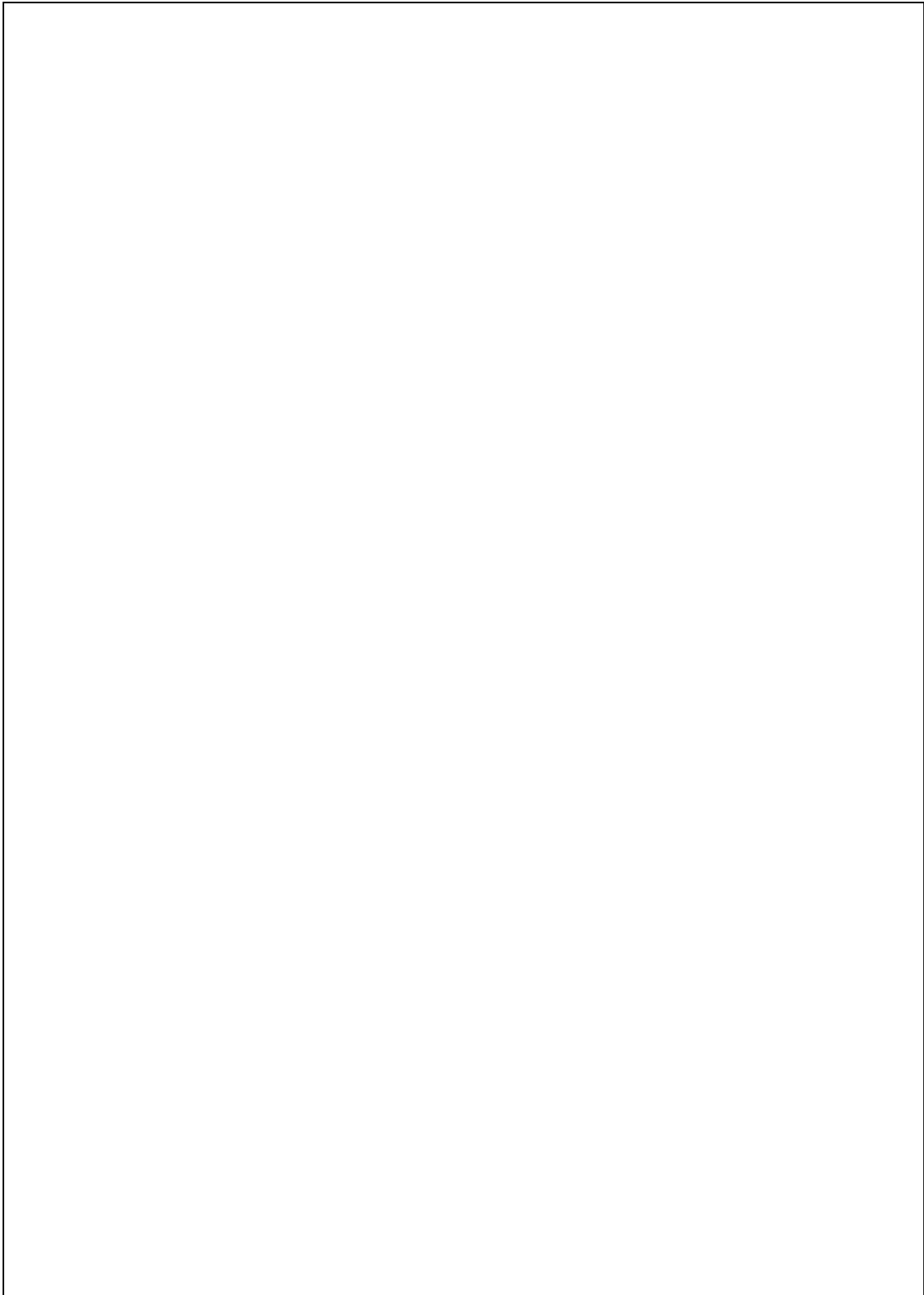

Physical Dimensions inches (millimeters) unless otherwise noted

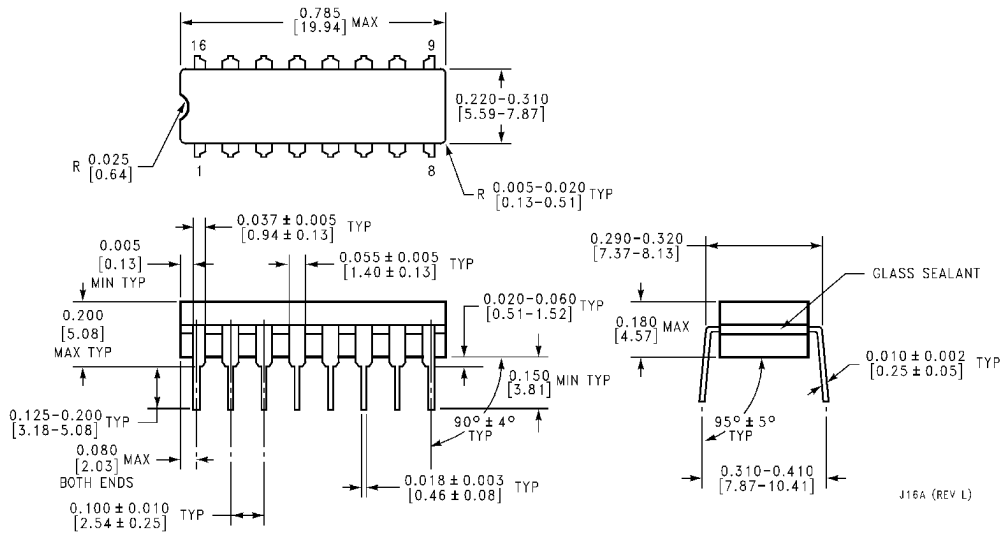

16-Lead Ceramic Dual-In-Line Package (J)
Order Number 5476DMQB or DM5476J
Package Number J16A

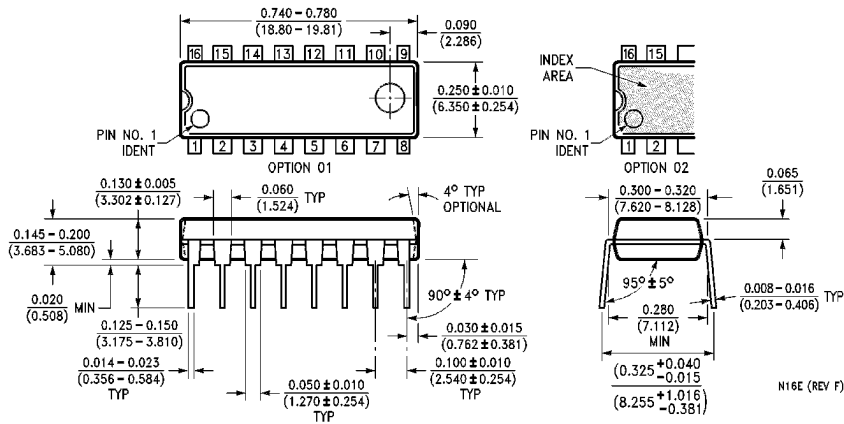

16-Lead Molded Dual-In-Line Package (N)
Order Number DM7476N
Package Number N16E

Physical Dimensions inches (millimeters) unless otherwise noted (Continued)

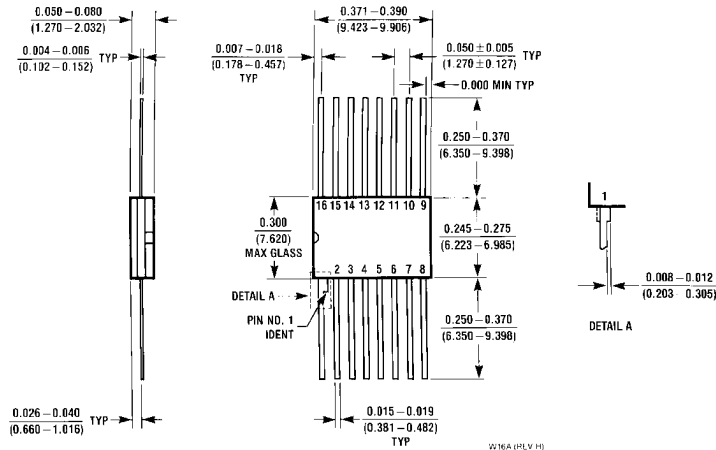

16-Lead Ceramic Flat Package (W)
Order Number 5476FMQB or DM7476W
Package Number W16A

LIFE SUPPORT POLICY

FAIRCHILD'S PRODUCTS ARE NOT AUTHORIZED FOR USE AS CRITICAL COMPONENTS IN LIFE SUPPORT DEVICES OR SYSTEMS WITHOUT THE EXPRESS WRITTEN APPROVAL OF THE PRESIDENT OF FAIRCHILD SEMICONDUCTOR CORPORATION. As used herein:

1. Life support devices or systems are devices or systems which, (a) are intended for surgical implant into the body, or (b) support or sustain life, and (c) whose failure to perform when properly used in accordance with instructions for use provided in the labeling, can be reasonably expected to result in a significant injury to the user.
2. A critical component in any component of a life support device or system whose failure to perform can be reasonably expected to cause the failure of the life support device or system, or to affect its safety or effectiveness.

Fairchild Semiconductor Corporation
 Americas
 Customer Response Center
 Tel: 1-888-522-5372

Fairchild Semiconductor Europe
 Fax: +49 (0) 1 80-530 85 86
 Email: europe.support@nsc.com
 Deutsch Tel: +49 (0) 8 141-35-0
 English Tel: +44 (0) 1 793-85-68-56
 Italy Tel: +39 (0) 2 57 5631

Fairchild Semiconductor Hong Kong Ltd.
 13th Floor, Straight Block,
 Ocean Centre, 5 Canton Rd.
 Tsimshatsui, Kowloon
 Hong Kong
 Tel: +852 2737-7200
 Fax: +852 2314-0061

National Semiconductor Japan Ltd.
 Tel: 81-3-5620-6175
 Fax: 81-3-5620-6179

www.fairchildsemi.com

Fairchild does not assume any responsibility for use of any circuitry described, no circuit patent licenses are implied and Fairchild reserves the right at any time without notice to change said circuitry and specifications.