

# DATA SHEET

## **TDA2595** Horizontal combination

Product specification  
File under Integrated Circuits, IC02

March 1987

## Horizontal combination

## TDA2595

### GENERAL DESCRIPTION

The TDA2595 is a monolithic integrated circuit intended for use in colour television receivers.

#### Features

- Positive video input; capacitively coupled (source impedance < 200  $\Omega$ )
- Adaptive sync separator; slicing level at 50% of sync amplitude
- Internal vertical pulse separator with double slope integrator
- Output stage for vertical sync pulse or composite sync depending on the load; both are switched off at muting
- $\phi_1$  phase control between horizontal sync and oscillator
- Coincidence detector  $\phi_3$  for automatic time-constant switching; overruled by the VCR switch
- Time-constant switch between two external time-constants or loop-gain; both controlled by the coincidence detector  $\phi_3$
- $\phi_1$  gating pulse controlled by coincidence detector  $\phi_3$
- Mute circuit depending on TV transmitter identification
- $\phi_2$  phase control between line flyback and oscillator; the slicing levels for  $\phi_2$  control and horizontal blanking can be set separately
- Burst keying and horizontal blanking pulse generation, in combination with clamping of the vertical blanking pulse (three-level sandcastle)
- Horizontal drive output with constant duty cycle inhibited by the protection circuit or the supply voltage sensor
- Detector for too low supply voltage
- Protection circuit for switching off the horizontal drive output continuously if the input voltage is below 4 V or higher than 8 V
- Line flyback control causing the horizontal blanking level at the sandcastle output continuously in case of a missing flyback pulse
- Spot-suppressor controlled by the line flyback control

### QUICK REFERENCE DATA

Supply voltage (pin 15)	$V_{15-5} = V_P$	typ.	12 V
Sync pulse amplitude (positive video)	$V_{i(p-p)}$	min.	50 mV
Horizontal output current	$I_4$	typ.	50 mA

### PACKAGE OUTLINE

18-lead DIL; plastic (SOT102); SOT102-1; 1997 January 07.

Horizontal combination

TDA2595

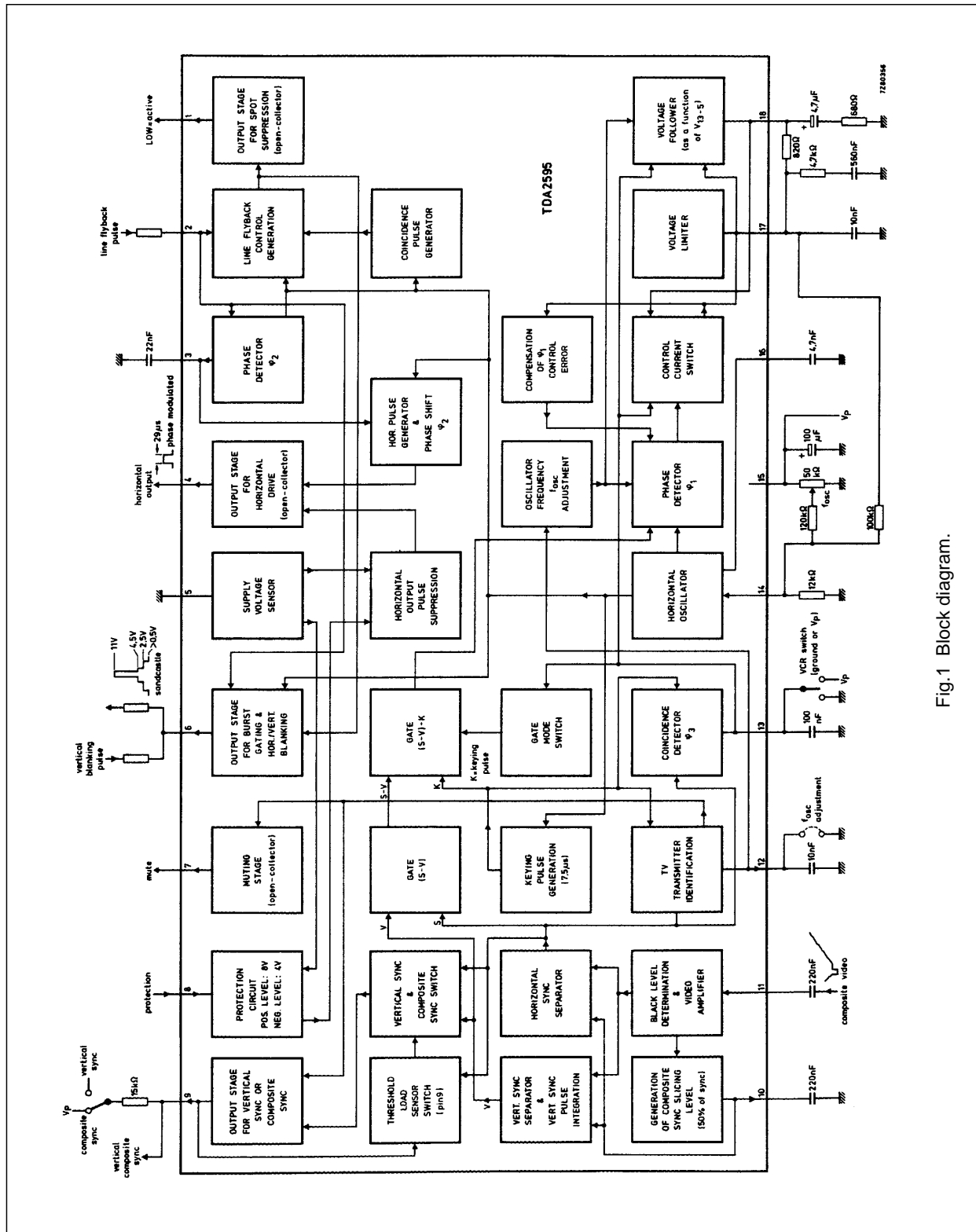

Fig.1 Block diagram.

## Horizontal combination

## TDA2595

**RATINGS**

Limiting values in accordance with the Absolute Maximum System (IEC 134)

Supply voltage (pin 15)	$V_{15-5} = V_P$	max.	13,2	V
Voltages at:				
pins 1, 4 and 7	$V_{1;4;7-5}$	max.	18	V
pins 8, 13 and 18	$V_{8;13;18-5}$	max.	$V_P$	V
pin 11 (range)	$V_{11-5}$		-0,5 to + 6	V
Currents at:				
pin 1	$I_1$	max.	10	mA
pin 2 (peak value)	$\pm I_{2M}$	max.	10	mA
pin 4	$I_4$	max.	100	mA
pin 6 (peak value)	$\pm I_{6M}$	max.	6	mA
pin 7	$I_7$	max.	10	mA
pin 8 (range)	$I_8$		-5 to +1	mA
pin 9 (range)	$I_9$		-10 to + 3	mA
pin 18	$\pm I_{18}$	max.	10	mA
Total power dissipation	$P_{tot}$	max.	800	mW
Storage temperature range	$T_{stg}$		-25 to + 125	°C
Operating ambient temperature range	$T_{amb}$		0 to + 70	°C

## Horizontal combination

## TDA2595

**CHARACTERISTICS**

$V_P = 12\text{ V}$ ;  $T_{\text{amb}} = 25\text{ }^\circ\text{C}$ ; measured in Fig.1; unless otherwise specified

PARAMETER	SYMBOL	MIN.	TYP.	MAX.	UNIT
<b>Composite video input and sync separator (pin 11)</b>					
(internal black level determination)					
Input signal (positive video; standard signal; peak-to-peak value)	$V_{11-5(p-p)}$	0,2	1	3	V
Sync pulse amplitude (independent of video content)	$V_{11-5(p-p)}$	50	–	–	mV
Generator resistance	$R_G$	–	–	200	$\Omega$
Input current during:					
video	$I_{11}$	–	5	–	$\mu\text{A}$
sync pulse	$-I_{11}$	–	40	–	$\mu\text{A}$
black level	$-I_{11}$	–	25	–	$\mu\text{A}$
<b>Composite sync generation (pin 10)</b>					
horizontal slicing level at 50% of the sync pulse amplitude for $V_{11-5(p-p)} < 1,5\text{ V}$					
Capacitor current during:					
video	$I_{10}$	–	16	–	$\mu\text{A}$
sync pulse	$-I_{10}$	–	170	–	$\mu\text{A}$
<b>Vertical sync pulse generation</b>					
slicing level at 30% (60% between black level and horizontal slicing level); pin 9					
Output voltage	$V_{9-5}$	10	–	–	V
Pulse duration	$t_p$	–	190	–	$\mu\text{s}$
Delay with respect to the vertical sync pulse (leading edge)	$t_d$	–	45	–	$\mu\text{s}$
Pulse-mode control					
output current for vertical sync pulse (dual integrated)		no current applied at pin 9			
output current for horizontal and vertical sync pulse (non-integrated separated signal)		current applied via a resistor of $15\text{ k}\Omega$ from $V_P$ to pin 9			

## Horizontal combination

## TDA2595

PARAMETER	SYMBOL	MIN.	TYP.	MAX.	UNIT
<b>Horizontal oscillator</b>					
(pins 14 and 16)					
Frequency; free running	$f_{osc}$	–	15 625	–	Hz
Reference voltage for $f_{osc}$	$V_{14-5}$	–	6	–	V
Frequency control sensitivity	$\Delta f_{osc}/\Delta I_{14}$	–	31	–	Hz/ $\mu$ A
Adjustment range of circuit Fig.1	$\Delta f_{osc}$	–	$\pm 10$	–	%
Spread of frequency	$\Delta f_{osc}$	–	–	5	%
Frequency dependency (excluding tolerance of external (components)					
with supply voltage ( $V_P = 12$ V)	$\frac{\Delta f_{osc}/f_{osc}}{\Delta V_{15-5}/V_{15-5}}$	–	$\pm 0,05$	–	
with supply voltage drop of 5 V	$\Delta f_{osc}$	–	–	10	%
with temperature	TC	–	–	$\pm 10^{-4}$	K <sup>-1</sup>
Capacitor current during:					
discharging	$+ I_{16}$	–	1024	–	$\mu$ A
charging	$- I_{16}$	–	313	–	$\mu$ A
Sawtooth voltage timing (pin 14)					
rise time	$t_r$	–	49	–	$\mu$ s
fall time	$t_f$	–	15	–	$\mu$ s
<b>Horizontal output pulse (pin 4)</b>					
Output voltage LOW at $I_4 = 50$ mA	$V_{4-5}$	–	–	0,5	V
Pulse duration (HIGH)	$t_p$	–	$29 \pm 1,5$	–	$\mu$ s
Supply voltage for switching off					
the output pulse (pin 15)	$V_P$	–	4	–	V
Hysteresis for switching					
on the output pulse	$\Delta V_P$	–	250	–	mV

## Horizontal combination

## TDA2595

PARAMETER	SYMBOL	MIN.	TYP.	MAX.	UNIT
<b>Phase comparison <math>\phi_1</math> (pin 17)</b>					
Control voltage range	$V_{17-5}$	3,55	–	8,3	V
Leakage current at $V_{17-5} = 3,55$ to $8,3$ V	$I_{17}$	–	–	1	$\mu\text{A}$
Control current for external time-constant switch	$\pm I_{17}$	1,8	2	2,2	mA
Control current at $V_{18-5} = V_{15-5}$ and $V_{13-5} < 2$ V or $V_{13-5} > 9,5$ V	$\pm I_{17}$	–	8	–	mA
Control current at $V_{18-5} = V_{15-5}$ and $V_{13-5} = 2$ to $9,5$ V	$\pm I_{17}$	1,8	2	2,2	mA
Horizontal oscillator control					
control sensitivity	$S_\phi$	6	–	–	kHz/ $\mu\text{s}$
catching and holding range	$\pm \Delta f_{\text{osc}}$	–	680	–	Hz
spread of catching and holding range	$\pm \Delta f_{\text{osc}}$	–	10	–	%
Internal keying pulse at $V_{13-5} = 2,9$ to $9,5$ V	$t_p$	–	7,5	–	$\mu\text{s}$
Time-constant switch					
slow time-constant at	$V_{13-5}$	9,5	–	2	V
fast time-constant at	$V_{13-5}$	2	–	9,5	V
Impedance converter offset voltage (slow time-constant)	$\pm V_{17-18}$	–	–	3	mV
Output resistance					
slow time-constant	$R_{18-5}$	–	–	10	$\Omega$
fast time-constant	$R_{18-5}$	high impedance			
Leakage current	$I_{18}$	–	–	1	$\mu\text{A}$

## Horizontal combination

## TDA2595

PARAMETER	SYMBOL	MIN.	TYP.	MAX.	UNIT
<b>Coincidence detector <math>\phi_3</math> (pin 13)</b>					
Output voltage					
without coincidence with composite video signal	$V_{13-5}$	–	–	1	V
without coincidence without composite video signal (noise)	$V_{13-5}$	–	–	2	V
with coincidence with composite video signal	$V_{13-5}$	–	6	–	V
Output current					
without coincidence with composite video signal	$I_{13}$	–	50	–	$\mu\text{A}$
with coincidence with composite video signal	$-I_{13}$	–	300	–	$\mu\text{A}$
Switching current					
at $V_{13-5} = V_P - 0,5 \text{ V}$	$I_{13}$	–	–	100	$\mu\text{A}$
at $V_{13-5} = 0,5 \text{ V}$ (average value)	$I_{13(\text{av})}$	–	–	100	$\mu\text{A}$
<b>Phase comparison <math>\phi_2</math> (pins 2 and 3) (see note 1)</b>					
<b>Input for line flyback pulse (pin 2)</b>					
Switching level for $\phi_2$ comparison and flyback control	$V_{2-5}$	–	3	–	V
Switching level for horizontal blanking	$V_{2-5}$	–	0,3	–	V
Input voltage limiting	$V_{2-5}$	–	–0,7	–	V
	or:	–	+4,5	–	V
Switching current					
at horizontal flyback	$I_2$	0,01	1	–	mA
at horizontal scan	$I_2$	–	–	2	$\mu\text{A}$
Maximum negative input current	$-I_2$	–	–	500	$\mu\text{A}$
<b>Phase detector output (pin 3)</b>					
Control current for $\phi_2$	$\pm I_3$	–	1	–	mA
Control range	$\Delta t_{\phi_2}$	–	19	–	$\mu\text{s}$
Static control error	$\Delta t / \Delta t_d$	–	–	0,2	%
Leakage current	$I_3$	–	–	5	$\mu\text{A}$



## Horizontal combination

## TDA2595

PARAMETER	SYMBOL	MIN.	TYP.	MAX.	UNIT
<b>Phase comparison</b> $\phi_2$ (pins 2 and 3) (continued)					
Phase relation between middle of the horizontal sync pulse and the middle of the line flyback pulse at $t_{fp} = 12 \mu\text{s}$ (note 2)	$\Delta t$	–	$2,6 \pm 0,7$	–	$\mu\text{s}$
If additional adjustment is required, it can be arranged by applying a current at pin 3	$\Delta I/\Delta t$	–	30	–	$\mu\text{A}/\mu\text{s}$
<b>Burst gating pulse</b> (pin 6) (note 3)					
Output voltage	$V_{6-5}$	10	11	–	V
Pulse duration	$t_p$	3,7	4	4,3	$\mu\text{s}$
Phase relation between middle of sync pulse at the input and the leading edge of the burst gating pulse at $V_{6-5} = 7 \text{ V}$	$t_{\phi 6}$	2,15	2,65	3,15	$\mu\text{s}$
Output trailing edge current	$I_6$	–	2	–	mA
<b>Horizontal blanking pulse</b> (pin 6) (note 3)					
Output voltage	$V_{6-5}$	4,1	4,5	4,9	V
Output trailing edge current	$I_6$	–	2	–	mA
Saturation voltage at horizontal scan	$V_{6-5\text{sat}}$	–	–	0,5	V
<b>Clamping circuit for vertical blanking pulse</b> (pin 6) (note 3)					
Output voltage at $I_6 = 2,8 \text{ mA}$	$V_{6-5}$	2,15	2,5	3	V
Minimum output current at $V_{6-5} > 2,15 \text{ V}$	$I_{6\text{min}}$	–	2,3	–	mA
Maximum output current at $V_{6-5} < 3 \text{ V}$	$I_{6\text{max}}$	–	3,3	–	mA
<b>TV-transmitter identification</b> (pin 12) (note 4)					
Output voltage no TV transmitter	$V_{12-5}$	–	–	1	V
TV transmitter identified	$V_{12-5}$	7	–	–	V

## Horizontal combination

## TDA2595

PARAMETER	SYMBOL	MIN.	TYP.	MAX.	UNIT
<b>Mute output (pin 7)</b>					
Output voltage at $I_7 = 3 \text{ mA}$ no TV transmitter	$V_{7-5}$	–	–	0,5	V
Output resistance at $I_7 = 3 \text{ mA}$ no TV transmitter	$R_{7-5}$	–	–	100	$\Omega$
Output leakage current at $V_{12-5} > 3 \text{ V}$ TV transmitter identified	$I_7$	–	–	5	$\mu\text{A}$
<b>Protection circuit (beam-current/ EHT voltage protection) (pin 8)</b>					
No-load voltage for $I_8 = 0$ (operative condition)	$V_{8-5}$	–	6	–	V
Threshold at positive-going voltage	$V_{8-5}$	–	$8 \pm 0,8$	–	V
Threshold at negative-going voltage	$V_{8-5}$	–	$4 \pm 0,4$	–	V
Current limiting for $V_{8-5} = 1 \text{ to } 8,5 \text{ V}$	$\pm I_8$	–	60	–	$\mu\text{A}$
Input resistance for $V_{8-5} > 8,5 \text{ V}$	$R_{8-5}$	–	3	–	$\text{k}\Omega$
Internal response delay of threshold switch	$t_d$	–	10	–	$\mu\text{s}$
<b>Control output of line flyback pulse control (pin 1)</b>					
Saturation voltage at standard operation; $I_7 = 3 \text{ mA}$	$V_{1-5\text{sat}}$	–	–	0,5	V
Output leakage current in case of disturbance of line flyback pulse	$I_1$	–	–	5	$\mu\text{A}$

**Notes to the characteristics**

1. Phase comparison between horizontal oscillator and the line flyback pulse. Generation of a phase modulated ( $\varphi_2$ ) horizontal output pulse with constant duration.
2.  $t_{fp}$  is the line flyback pulse duration.
3. Three-level sandcastle pulse.
4. If pin 12 is connected to  $V_p$  the vertical output is active independent of synchronization state.

Horizontal combination

TDA2595

PACKAGE OUTLINE

DIP18: plastic dual in-line package; 18 leads (300 mil)

SOT102-1

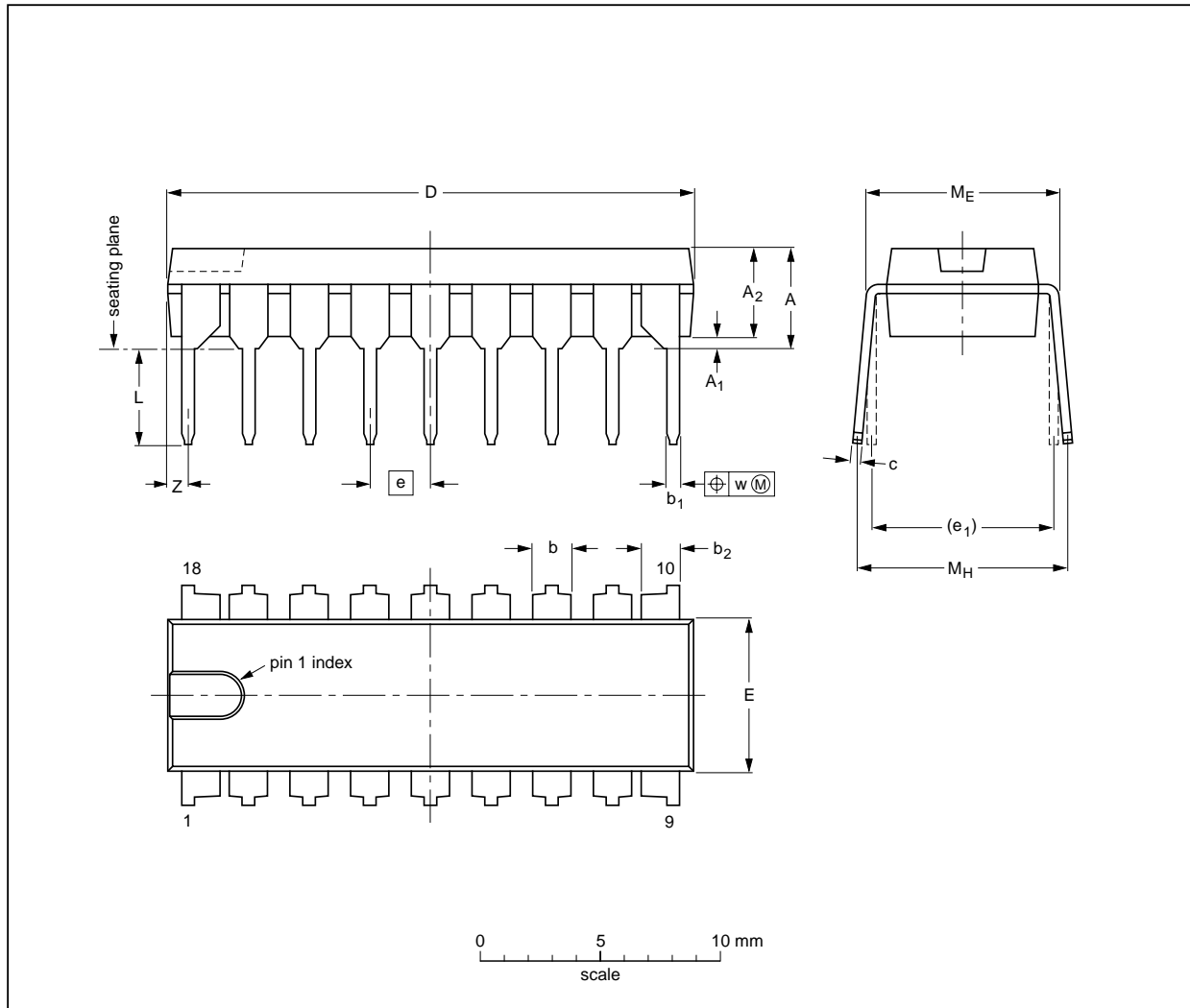

DIMENSIONS (inch dimensions are derived from the original mm dimensions)

UNIT	A max.	A <sub>1</sub> min.	A <sub>2</sub> max.	b	b <sub>1</sub>	b <sub>2</sub>	c	D <sup>(1)</sup>	E <sup>(1)</sup>	e	e <sub>1</sub>	L	M <sub>E</sub>	M <sub>H</sub>	w	Z <sup>(1)</sup> max.
mm	4.7	0.51	3.7	1.40 1.14	0.53 0.38	1.40 1.14	0.32 0.23	21.8 21.4	6.48 6.20	2.54	7.62	3.9 3.4	8.25 7.80	9.5 8.3	0.254	0.85
inches	0.19	0.020	0.15	0.055 0.044	0.021 0.015	0.055 0.044	0.013 0.009	0.86 0.84	0.26 0.24	0.10	0.30	0.15 0.13	0.32 0.31	0.37 0.33	0.01	0.033

Note

1. Plastic or metal protrusions of 0.25 mm maximum per side are not included.

OUTLINE VERSION	REFERENCES				EUROPEAN PROJECTION	ISSUE DATE
	IEC	JEDEC	EIAJ			
SOT102-1						93-10-14 95-01-23

## Horizontal combination

TDA2595

### SOLDERING

#### Introduction

There is no soldering method that is ideal for all IC packages. Wave soldering is often preferred when through-hole and surface mounted components are mixed on one printed-circuit board. However, wave soldering is not always suitable for surface mounted ICs, or for printed-circuits with high population densities. In these situations reflow soldering is often used.

This text gives a very brief insight to a complex technology. A more in-depth account of soldering ICs can be found in our "IC Package Databook" (order code 9398 652 90011).

#### Soldering by dipping or by wave

The maximum permissible temperature of the solder is 260 °C; solder at this temperature must not be in contact with the joint for more than 5 seconds. The total contact time of successive solder waves must not exceed 5 seconds.

The device may be mounted up to the seating plane, but the temperature of the plastic body must not exceed the specified maximum storage temperature ( $T_{stg\ max}$ ). If the printed-circuit board has been pre-heated, forced cooling may be necessary immediately after soldering to keep the temperature within the permissible limit.

#### Repairing soldered joints

Apply a low voltage soldering iron (less than 24 V) to the lead(s) of the package, below the seating plane or not more than 2 mm above it. If the temperature of the soldering iron bit is less than 300 °C it may remain in contact for up to 10 seconds. If the bit temperature is between 300 and 400 °C, contact may be up to 5 seconds.

### DEFINITIONS

Data sheet status	
Objective specification	This data sheet contains target or goal specifications for product development.
Preliminary specification	This data sheet contains preliminary data; supplementary data may be published later.
Product specification	This data sheet contains final product specifications.
Limiting values	
Limiting values given are in accordance with the Absolute Maximum Rating System (IEC 134). Stress above one or more of the limiting values may cause permanent damage to the device. These are stress ratings only and operation of the device at these or at any other conditions above those given in the Characteristics sections of the specification is not implied. Exposure to limiting values for extended periods may affect device reliability.	
Application information	
Where application information is given, it is advisory and does not form part of the specification.	

### LIFE SUPPORT APPLICATIONS

These products are not designed for use in life support appliances, devices, or systems where malfunction of these products can reasonably be expected to result in personal injury. Philips customers using or selling these products for use in such applications do so at their own risk and agree to fully indemnify Philips for any damages resulting from such improper use or sale.