

TC9153AP, TC9154AP

T-77-21

ELECTRONIC VOLUME.

The TC9153/54AP is an optimum C2MOS IC which has been designed for electrization of volume control of audio equipment, ect. with the following features.

- Attenuation can be controlled from 0dB to -66dB by 2dB/step.
- 2 channels have been built in.
- Both of dual power supplies of (+) and (-) and a single power supply can be used.
- The TC9153AP is capable of controlling attenuation by means of the built-in oscillator and the up/down terminals.
- The TC9154AP is capable of optionally controlling attenuation and channel balance when specified signals are externally applied to the data, clock and strobe input terminals.
- Being in C2-MOS structure, the operating voltage range is wide and current consumption is low.

VDD=6 ~ 12(V) (Backup is possible up to 4V)

MAXIMUM RATINGS (Ta=25°C)

CHARACTERISTIC	SYMBOL	RATING	UNIT
Supply Voltage	VDD	13	V
Input Voltage	VIN	VSS-0.3 ~ VDD+0.3	V
Power Dissipation	PD	150	mW
Operating Temperature	Topr	-30 ~ 75	°C
Storage Temperature	Tstg	-55 ~ 125	°C

Unit in mm

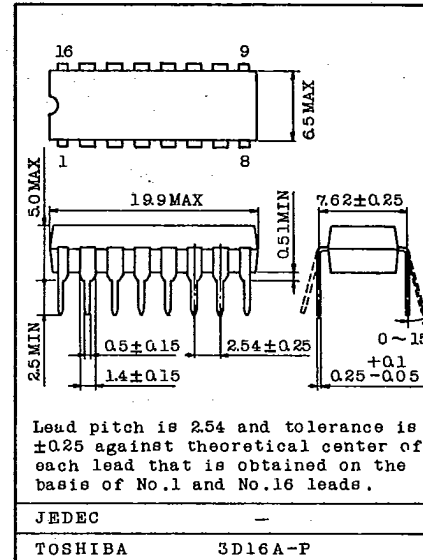

Weight : 1.0g

PIN CONNECTION

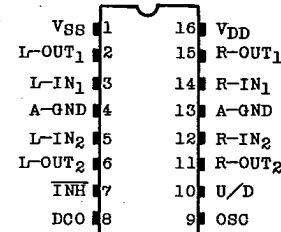

TC9153AP

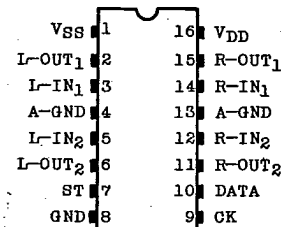

TC9154AP

TOSHIBA

TC9153AP, TC9154AP

T-77-21

BLOCK DIAGRAM

TC9153AP

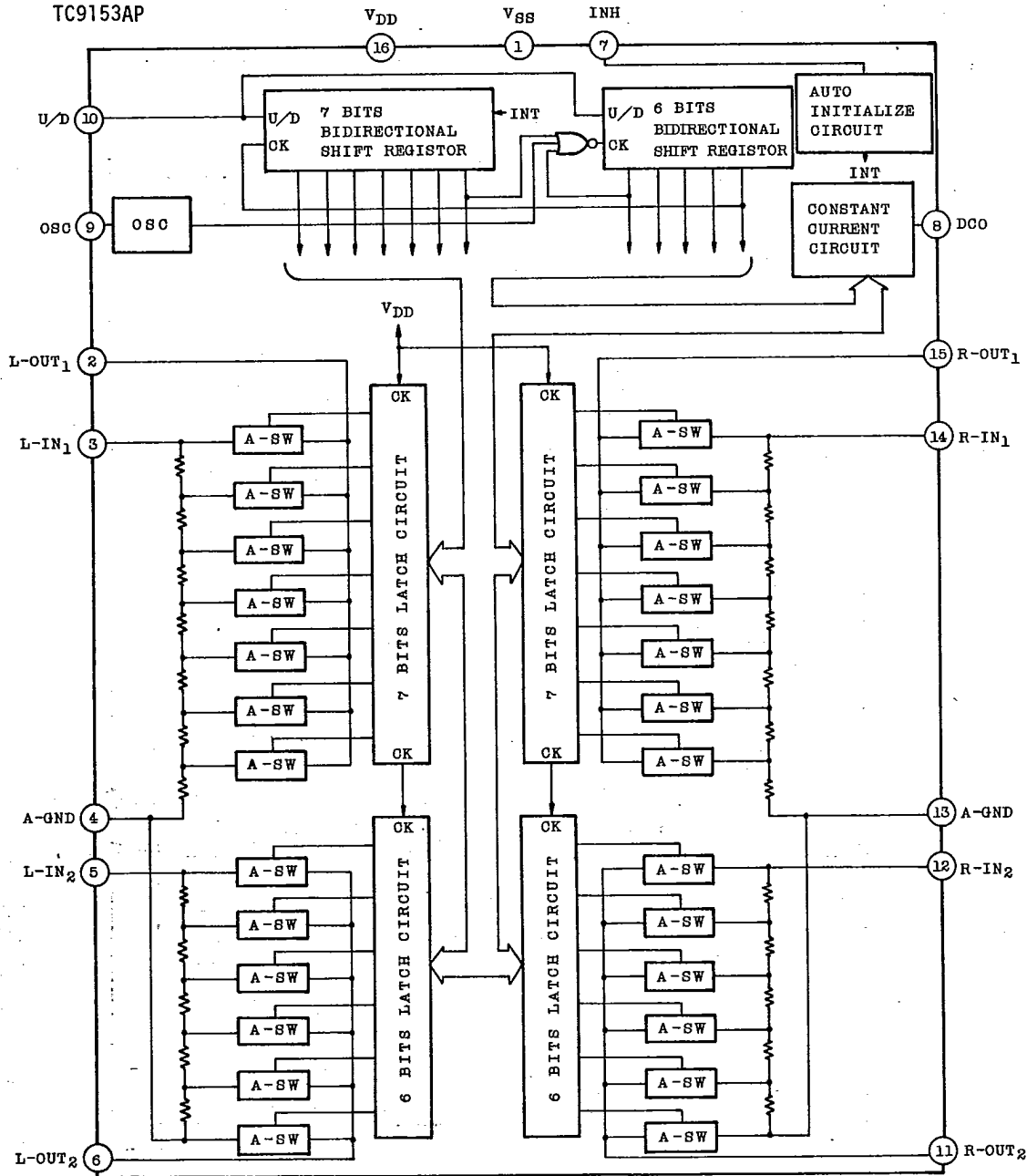

AUDIO DIGITAL IC

TC9153AP, TC9154AP

T-77-21

BLOCK DIAGRAM
TC9154AP

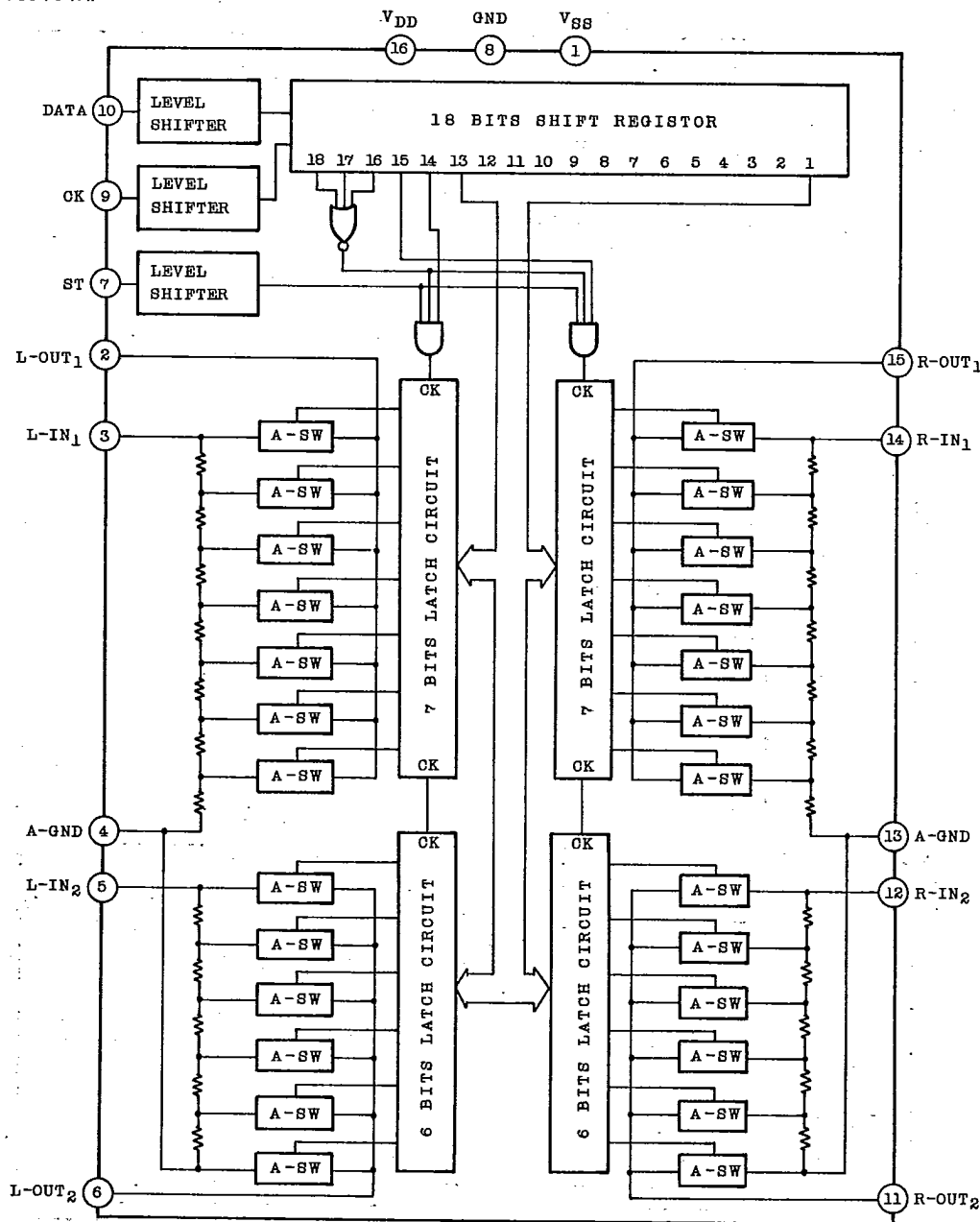

TOSHIBA

TC9153AP, TC9154AP

T-77-21

ELECTRICAL CHARACTERISTICS

TC9153AP (Unless otherwise specified, $V_{DD}=12V$, $V_{SS}=0V$, $T_a=25^\circ C$)

CHARACTERISTIC	SYMBOL	TEST CIR-CUIT	TEST CONDITION	MIN.	TYP.	MAX.	UNIT
Operating Supply Voltage	V_{DD}	-		6	-	12	V
Operating Supply Current	I_{DD}	-		-	1	3	mA
Backup Current	I_B	-	$V_{DD}=4V$, INH="L"	-	-	10	μA
Input Voltage	"H" Level	V_{IH}	INH, U/D Terminal	$0.8 \times V_{DD}$	-	$V_{DD}+0.3$	V
	"L" Level	V_{IL}		$V_{SS}-0.3$	-	$V_{DD} \times 0.2$	
Attenuator 1 (10dB/step) Resistor	RATT-1	-	R-IN1 (L-IN1) -A-GND	25	50	70	k Ω
Attenuator 2 (2dB/step) Resistor	RATT-2	-	R-IN2 (L-IN2) -A-GND	10	20	28	k Ω
Attenuation Error	-	-		-	-	2	dB
Max. Input Amplitude	V_{in}	-	Biase $V_{DD}/2=6V$	-	-	4.0	V_{rms}
Operating Oscillation Frequency	f_{OSC}	-		5	-	10k	Hz
DCO Output Current	I_{DCO}	-	1 Step	70	100	140	μA
Total Harmonic Distortion	THD	-	ATT=-10dB $f_{in}=1kHz$ $V_{in}=1.0Vp-p$	-	0.005	0.01	%

TC9154AP (Unless otherwise specified, $V_{DD}=6V$, $V_{SS}=-6V$, $GND=0V$, $T_a=25^\circ C$)

CHARACTERISTIC	SYMBOL	TEST CIR-CUIT	TEST CONDITION	MIN.	TYP.	MAX.	UNIT
Operating Supply Voltage	V_{DD}	-		6	-	12	V
Operating Supply Current	I_{DD}	-		-	1	3	mA
Static Supply Current	$I_{DD(S)}$	-		-	-	300	μA
Input Voltage	"H" Level	V_{IH}	CK, DATA, ST Terminal	$V_{DD} \times 0.8$	-	$V_{DD}+0.3$	V
	"L" Level	V_{IL}		-0.3	-	$V_{DD} \times 0.2$	
Attenuator 1 (10dB/step) Resistor	RATT-1	-	R-IN1 (L-IN1) -A-GND	25	50	70	k Ω
Attenuator 2 (2dB/step) Resistor	RATT-2	-	R-IN2 (L-IN2) -A-GND	10	20	28	k Ω
Attenuation Error	-	-		-	-	2	dB
Max. Input Amplitude	V_{in}	-	Biase 0V	-	-	4.0	V_{rms}
Max. Clock Frequency	f_{ck}	-		-	-	100	kHz
Min. Clock Width	T_{ck}	-		5	-	-	μsec
Total Harmonic Distortion	THD	-	ATT=-10dB $f_{in}=1kHz$ $V_{in}=1.0Vp-p$	-	0.005	0.01	%

AUDIO DIGITAL IC

TC9153AP, TC9154AP

T-77-21

FUNCTIONAL DESCRIPTION OF EACH TERMINAL

TERMINAL No.	SYMBOL	FUNCTION	REMARKS
2 15	L-OUT1 R-OUT1	10dB/step attenuator outputs. A signal applied to IN is attenuated in 7 steps from 0dB to 60dB at 10dB/step.	L and R are symmetrical.
3 14	L-IN1 R-IN1	10dB/step attenuator inputs.	
4 13	A-GND	Analog ground terminal	
5 12	L-IN2 R-IN2	2dB/step attenuator inputs.	
6 11	L-OUT2 R-OUT2	2dB/step attenuator outputs. A signal applied to IN is attenuated in 5 steps from 0dB to 8dB at 2dB/step.	

TC9153AP

7	INH	Inhibit terminal. When this terminal is at "L" level, all input/output cut off and the TC9153AP is placed in the inhibit state. When at "H" level, the TC9153AP operates normally.	
8	DCO	DC current output for displaying attenuation. Attenuation $0 \sim \infty$ is divided into 13 steps and approx. $100\mu\text{A}/\text{step}$ is transmitted. 	<p>Attenuation can be converted to DC voltage by attaching a resistor between this terminal and VSS.</p>
9	OSC	C, R connecting terminal for the oscillator. Up/down speed of attenuation is decided by the attenuation up/down control oscillator according to this time constant.	
10	U/D	Attenuation up/down control input terminal. When this terminal is at "H" level, sound volume is increased synchronizing with rise of the oscillator. Conversely, when this pin is at "L" level, sound volume is decreased.	With pull-up resistor.

TOSHIBA



TC9153AP, TC9154AP

T-77-21

TC9154AP

TERMINAL No.	SYMBOL	FUNCTION	REMARKS
10	DATA	Attenuation channel selection data input terminal. Data consists of 18 bits and inputted by CK signal.	
9	CK	Clock input terminal. Clock input terminal for taking data from DATA terminal.	
7	ST	Strobe input terminal. Attenuation channel selection signals taken from DATA and CK terminals are latched when this terminal is placed at "H" level. When no "H" level signal is applied to this terminals, previous data is kept maintained.	
1	VSS	(-) Power supply terminal.	
16	VDD	(+) Power supply terminal.	
(8)	GND	Earth terminal only for TC9154AP.	

AUDIO DIGITAL IC

TC9153AP, TC9154AP

T-77-21

DESCRIPTION OF OPERATION

1. SETTING OF ATTENUATION

Setting of attenuation differs between the TC9153AP and TC9154AP.

On the TC9153AP, attenuation can be increased/decreased according to the state of U/D terminal ("H" or "L" level) by actuating the built-in oscillator.

On the TC9154AP, attenuation can be set at optional level by inputting specified data to the DATA, CK and ST terminals, respectively.

In Case of TC9153AP

On the TC9153AP, attenuation is automatically set at the -40dB position when power is applied.

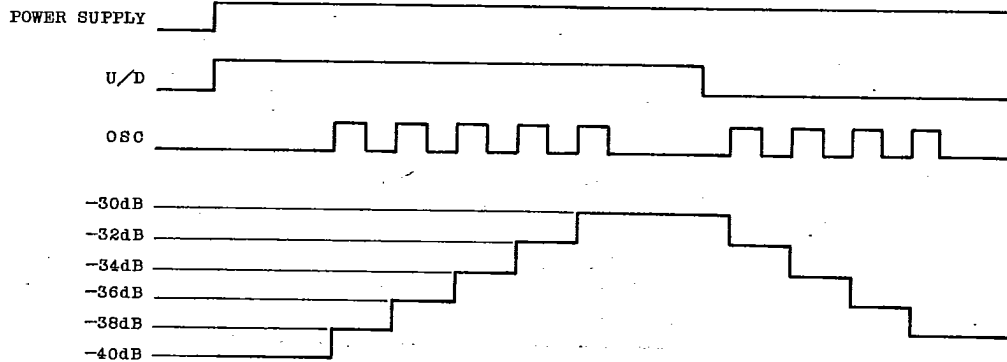

When the UP key is pressed after power ON, the U/D terminal is placed in the up state at "H" level, and the oscillator is actuated.

When the DOWN key is pressed, the U/D terminal is kept at "L" level as long as the DOWN key is pressed, and the oscillator is actuated in the down state and therefore, attenuation is decreased.

Oscillation frequency is decided by C_X and R_X .

$$f_{OSC} \doteq \frac{1}{0.7 C_X \cdot R_X} \text{ (Hz)} \quad (R_S \geq 3R_X)$$

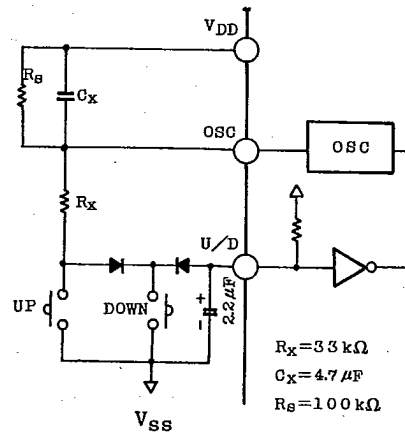

TC9153AP, TC9154AP

T-77-21

In Case of TC9154AP

On the TC9154P, optional attenuation data is inputted through the DATA, CK and ST terminals. Data consists of 18 bits as follows.

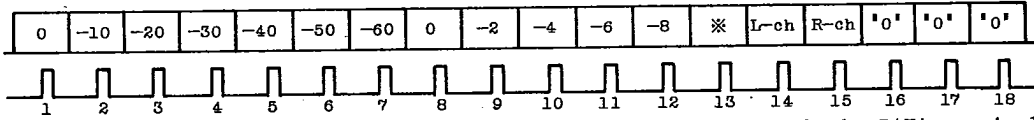

For instance, when data of (000100001000011000) is inputted through the DATA terminal, attenuation is set at -32dB.

Bits 1~7 of the data are set at a unit of 10dB and 8~12 at a unit of 2dB.

Bit 13 can be at either "1" or "0". Bits 14 and 15 are for selecting the left and right channels and "1", "0"=Lch, "0", "1"=Rch, and "1", "1"=L & Rch.

Bits 16~18 are fixed at "0".

Infinite attenuation is set by -68dB data and therefore, if attenuation is increased from the infinite quantity by one step, it becomes -66dB.

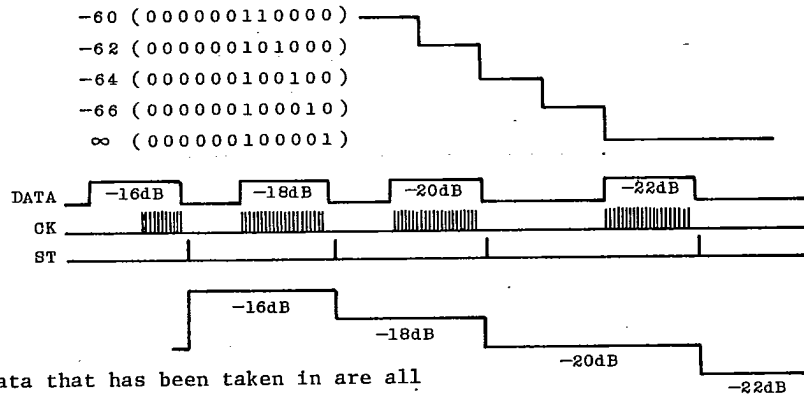

Changes to data that has been taken in are all synchronized with ST signal.

TIMING OF DATA, CK AND ST

DATA, CK and ST should be inputted under the conditions shown below.

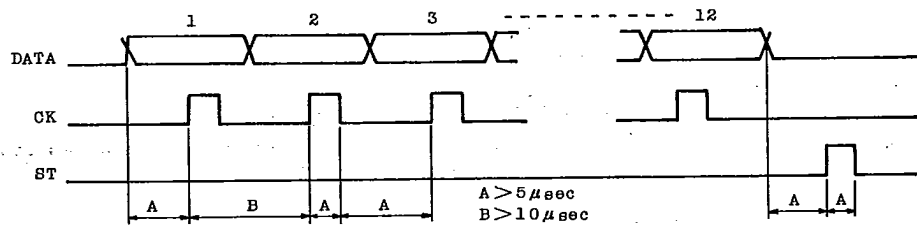

AUDIO DIGITAL IC

TC9153AP, TC9154AP

T-77-21

ATTENUATION DISPLAY OUTPUT

The TC9153AP is provided with the DC current output terminal for displaying attenuation. With 0dB~∞ divided into 13 steps, current of approx. 100μA/step is transmitted.

STEP	DCO	ATTENUATION
0	0	-64dB ~ ∞
1	$I=100\mu A \pm 30\mu A$	-60dB ~ -62dB
2	$2 \times I$	-54dB ~ -58dB
3	$3 \times I$	-50dB ~ -52dB
4	$4 \times I$	-44dB ~ -48dB
5	$5 \times I$	-40dB ~ -42dB
6	$6 \times I$	-34dB ~ -38dB
7	$7 \times I$	-30dB ~ -32dB
8	$8 \times I$	-24dB ~ -28dB
9	$9 \times I$	-20dB ~ -22dB
10	$10 \times I$	-14dB ~ -18dB
11	$11 \times I$	-10dB ~ -12dB
12	$12 \times I$	-4dB ~ -8dB
13	$13 \times I$	0dB ~ -2dB

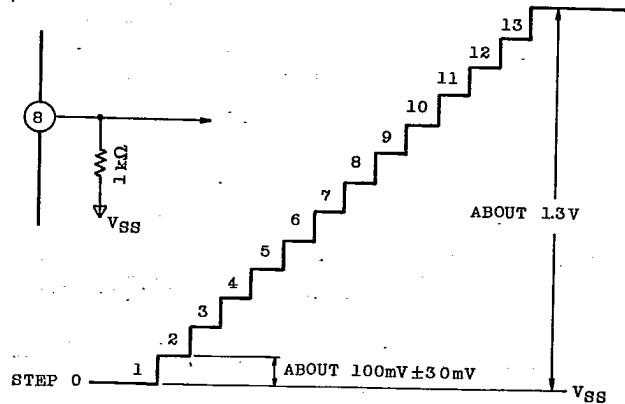

* Current value may fluctuate depending upon IC.
When high precision is required, use a variable resistor as a load resistor.

TOSHIBA

TC9153AP, TC9154AP

T-77-21

ATTENUATOR

The attenuator unit consist of diffused resistors and analog switches.

Attenuator-1 attenuates 0~60dB at 10dB/step while Attenuator-2 attenuates 2~8dB at 2dB/step, a total of 0~66dB at 2dB/step.

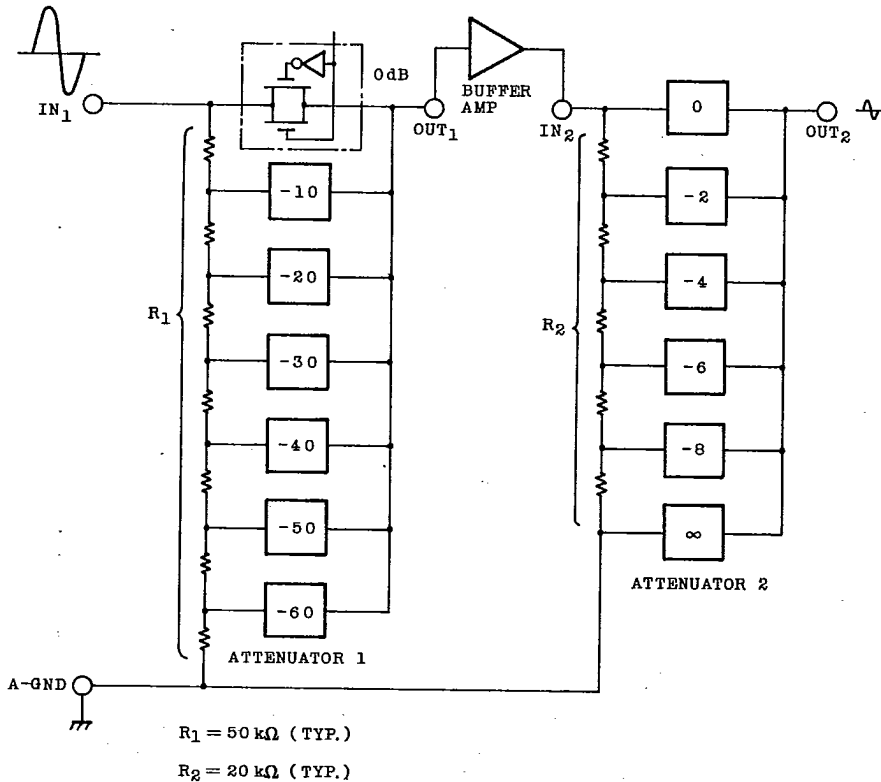

If there is the possibility for excessive voltage being to the attenuator, it is recommended to insert a protective diode as illustrated below.

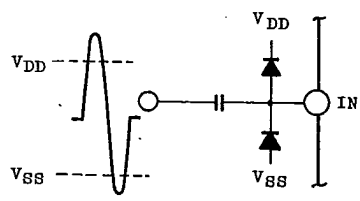

AUDIO DIGITAL IC

TC9153AP, TC9154AP

T-77-21

POWER SUPPLY

TC9153AP

. IN CASE OF DUAL POWER SUPPLIES

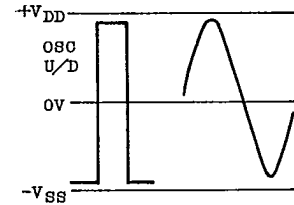
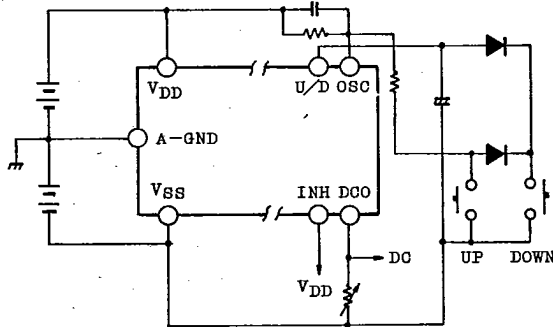

. IN CASE OF SINGLE POWER SUPPLY

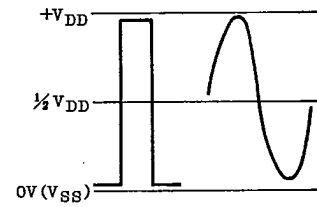
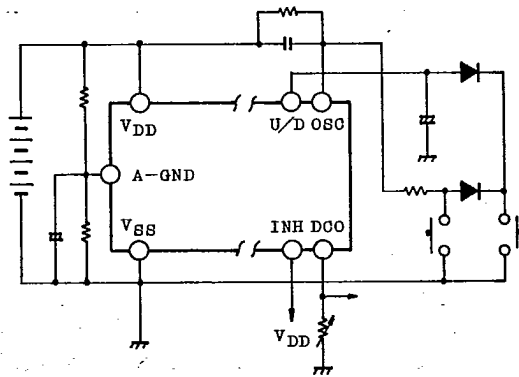

TC9153AP, TC9154AP

T-77-21

TC9154AP

As the TC9154AP has a built-in level shifter, DATA, CK and ST inputs can be operated by a single power supply (V_{DD} -GND) even when Dual power supplies are used. As a result, it has become easy to connect to a microcomputer, other controller.

. IN CASE OF DUAL POWER SUPPLY

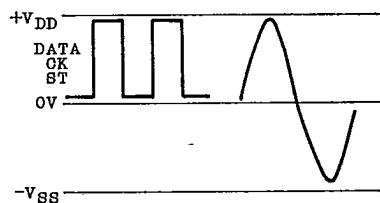
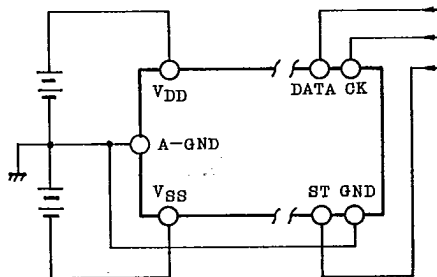

. IN CASE OF SINGLE POWER SUPPLY

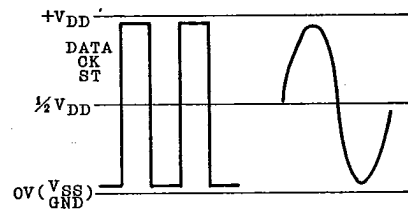
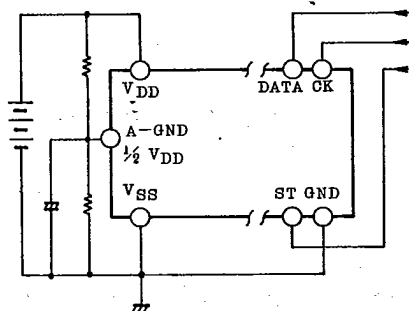

AUDIO DIGITAL IC

TC9153AP, TC9154AP

T-77-21

BACKUP WHEN POWER OFF

On the TC9153AP, when the INH terminal is set at "L" ($-V_{SS}$) level, all input/output terminal are shut off and current consumption is reduced to the minimum.

The backup by means of a capacitor becomes possible in this condition. An example of application when a backup capacitor is used is shown below.

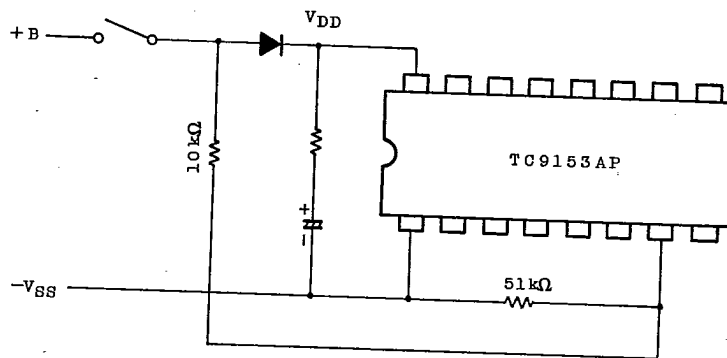

* If $V_{DD}-V_{SS}$ drops below 4.0V, the backup becomes impossible.

The TC9154AP is of such type that attenuation data is supplied externally and has no INH pin and therefore, is not suited for the backup. It is recommended to perform the backup at the controller side and to input holding data when power is ON.

TOSHIBA

TC9153AP, TC9154AP

T-77-21

INITIALIZATION WHEN POWER ON

The TC9153AP has the auto-initializing function built-in for initialization at time of power ON.

As the initializing system through detection of supply voltage level is adopted, if rise of power supply is too fast, the initialization may not be fully effected. (No external initialization is necessary.) In additions for effective initialization it is necessary that the INH terminal is raised simultaneously with supply voltage. Further, the initializing level is -40dB.

It is recommended to rise supply voltage and the INH terminal as illustrated below.

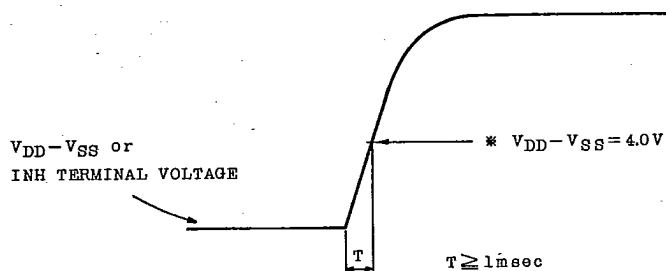

* On the TC9153AP, if $V_{DD}-V_{SS}$ drops below 4.0V, the auto-initializing function is actuated.

The TC9154AP is of such type that attenuation data is supplied externally, it has no built-in auto-initializing function. It is recommended to send data after power to the TC9154AP is raised.

AUDIO DIGITAL IC

TC9153AP, TC9154AP

T-77-21

TC9154/56AP APPLICATION CIRCUIT
(L-ch only)

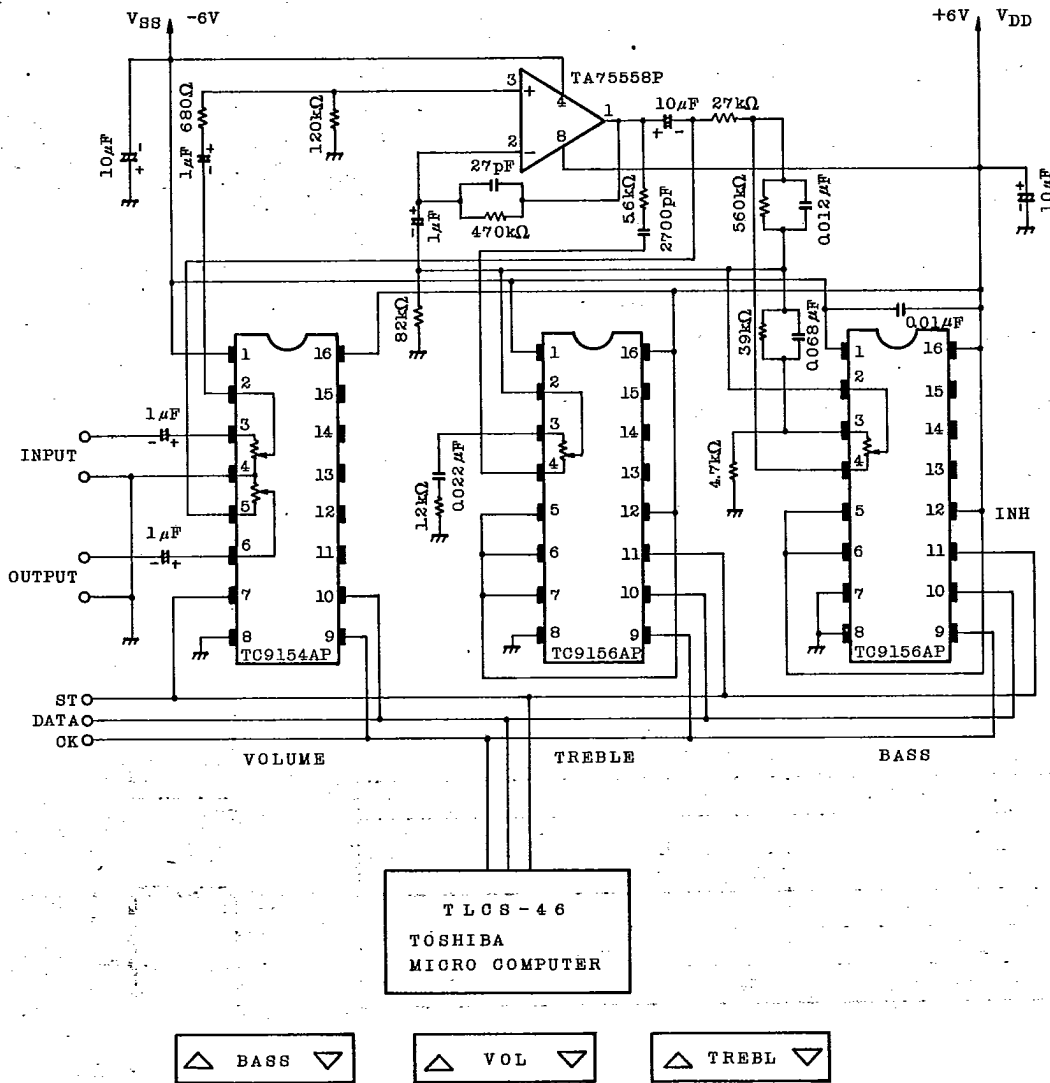

AUDIO DIGITAL IC