

# TA8859CP

## TV BIAS DISTORTION COMPENSATION IC

The TA8859CP is an IC for TV deflection stage to compensate various horizontal, vertical distortion, with a package of 16 pin DIP, controlled via I<sup>2</sup>C bus.

### FEATURES

- Vertical linearity correction
- Vertical S correction
- E-W parabola
- E-W corner
- Trapezium distortion compensation

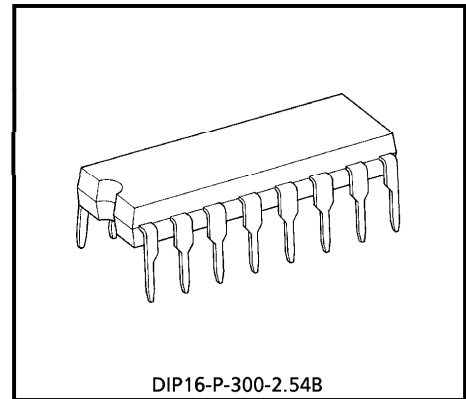

Weight : 1.11g (Typ.)

### BLOCK DIAGRAM

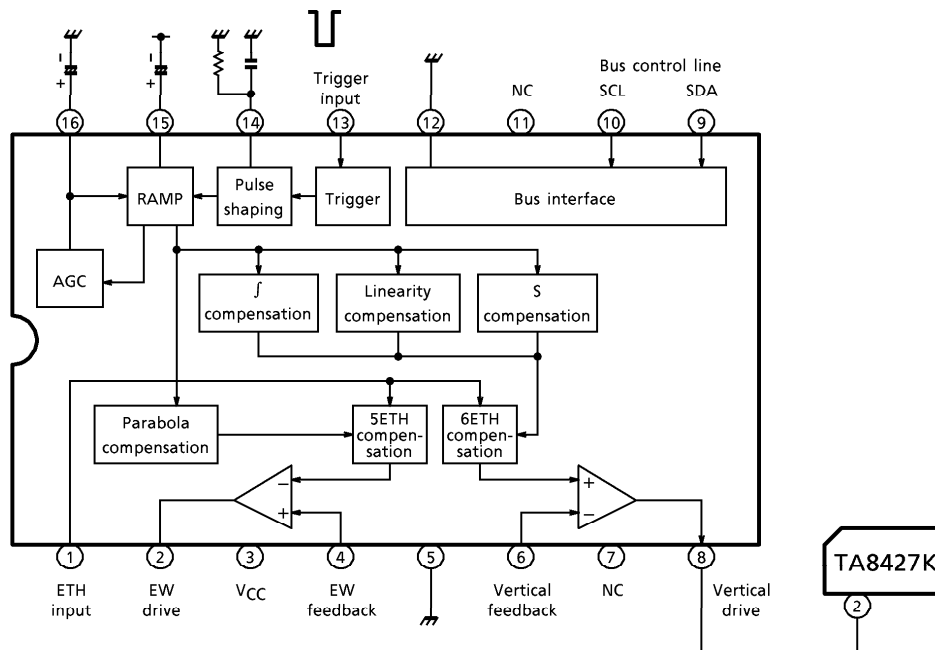



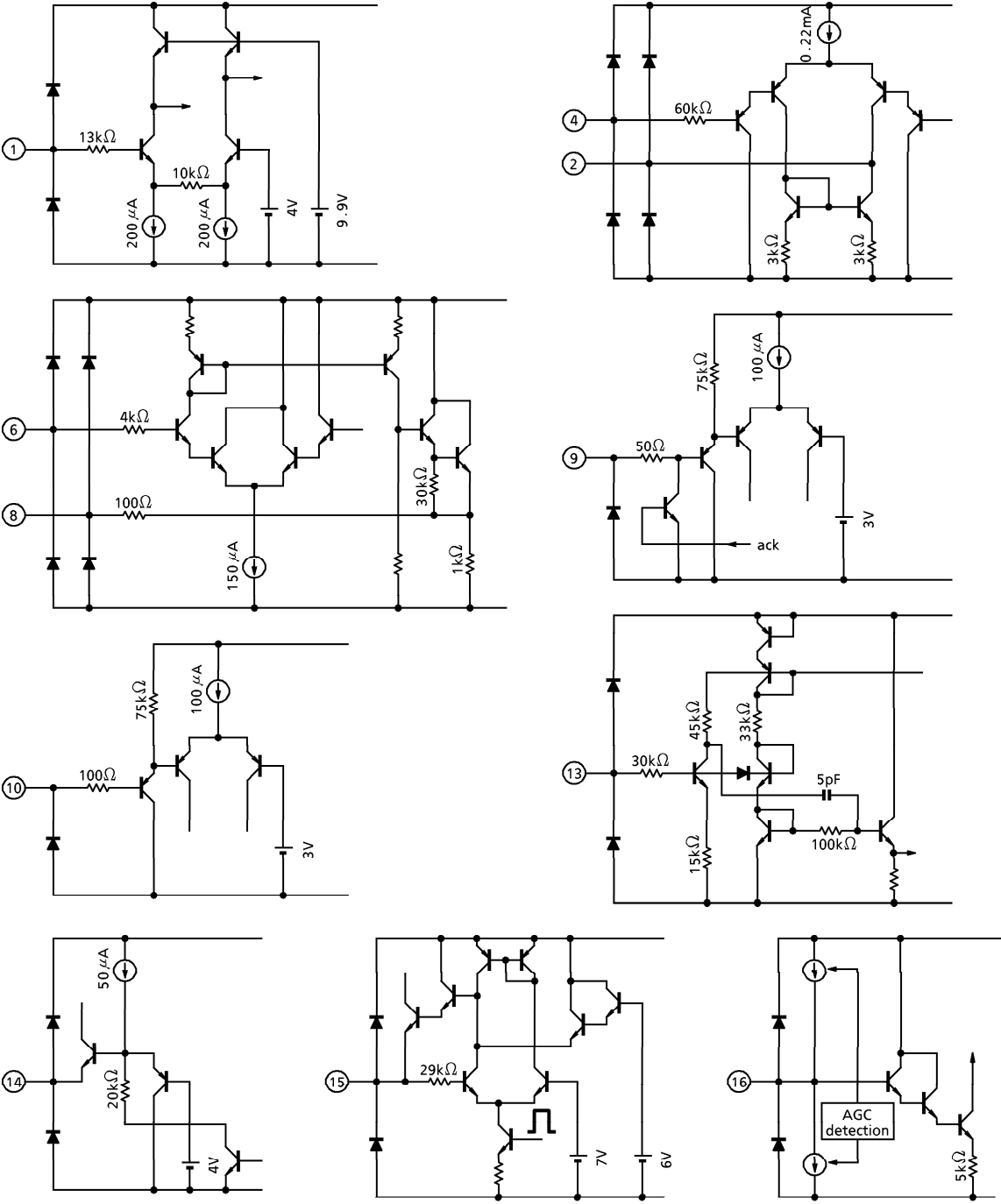

TERMINAL INTERFACE

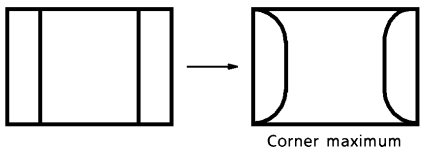

Downloaded from DatasheetLib.com - datasheet search engine

OUTLINE OF FUNCTIONS

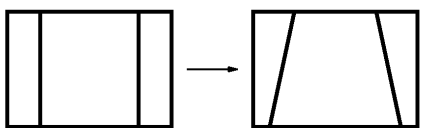
FUNCTION	SUB ADDRESS	BIT	OUTPUT WAVEFORM	PICTURE
Picture Height Adjustment	0010	6		
Vertical Linearity correction	0011	5		
Vertical "S" Correction (X <sup>3</sup> )	0100	5		
Vertical Shift	0101	3		
Vertical Compensation	0110	—		
Picture Width Adjustment	0111	6		
E-W Parabola	1000	6		

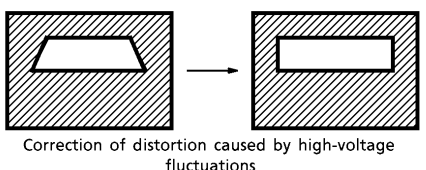
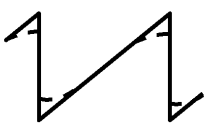
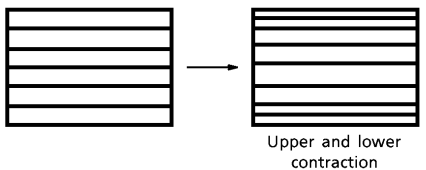
FUNCTION	SUB ADDRESS	BIT	OUTPUT WAVEFORM	PICTURE
E-W Corner Correction	1001	4		 <p>Corner maximum</p>
Trapezium Distortion Compensation	1010	6		
Horizontal Compensation	1011	—		 <p>Correction of distortion caused by high-voltage fluctuations</p>
Vertical $f$ Correction (X <sup>5</sup> )	1110	4		 <p>Upper and lower contraction</p>

I<sup>2</sup>C BUS CONTROL FUNCTIONS

FUNCTION	SUB ADDRESS	DATA	PRESET	RANGE
Picture Height	00000010	x-x-7bit	01000000	-48~48%
V-linearity	00000011	x-x-x-5bit	00010000	-13~13%
V-S Correction	00000100	x-x-x-5bit	00000000	0~22%
V-shift	00000101	x-x-x-AGC-3bit-x	00001000	-800~800mV
V-compensation	00000110	x-x-x-x-4bit	00000000	0~9%
Picture Width	00000111	x-x-6bit	00100000	1.6~7.3V
E-W Parabola	00001000	x-x-6bit	00100000	0~5.6V
E-W Corner	00001001	x-x-x-x-4bit	00000000	0~3.2V
Trapezium	00001010	x-x-6bit	00100000	0~1.2V
H-compensation	00001011	x-x-x-x-4bit	00000000	0~9%
V-f Correction	00001100	x-x-x-x-4bit	00000000	0~4%

- (Note 1) Vertical Height is controlled by Sub Address 02 (H), so no external control is required.
- (Note 2) AGC bit determines vertical AGC response speed.  
 0 : High speed for Channel/Mode change  
 1 : Low speed (1/5×High speed). for Normal reception/Text Mode.
- (Note 3) All registers are cleared into the preset value under the condition of  $V_{CC} \leq 3V$ .

I<sup>2</sup>C BUS CONTROL FORMAT OUTLINE

Bus controlled format of TA8859CP is based on I<sup>2</sup>C Bus Control format of PHILIPS.

Data transmission format

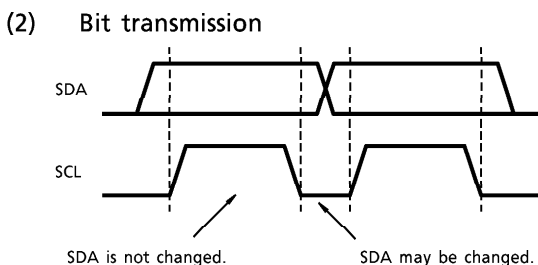
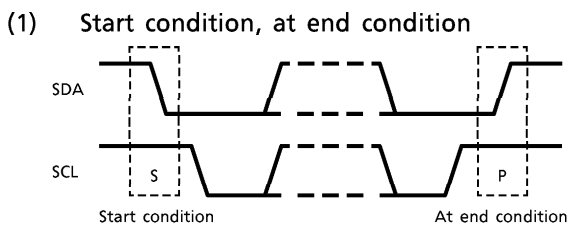

(3) Verification response

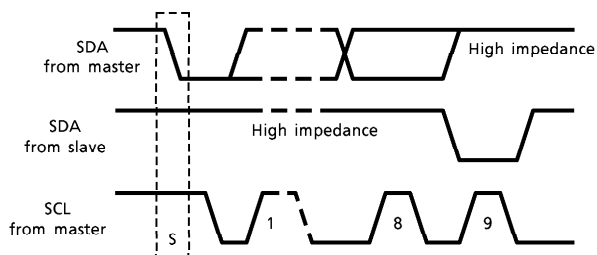

(4) Slave address

A6	A5	A4	A3	A2	A1	A0	R/W
1	0	0	0	1	1	0	0

Purchase of TOSHIBA I<sup>2</sup>C components conveys a license under the Philips I<sup>2</sup>C Patent Rights to use these components in an I<sup>2</sup>C system, provided that the system conforms to the I<sup>2</sup>C Standard Specification as defined by Philips.

**MAXIMUM RATINGS** (Ta = 25°C, VCC = 12V)

CHARACTERISTIC	SYMBOL	RATING	UNIT
Supply Voltage	VCC	15	V
Power Dissipation	PD max	1.4 (Note)	W
Input Signal Voltage	ein	5	Vp-p
Operating Temperature	Topr	-20~65	°C
Storage Temperature	Tstg	-55~150	°C

(Note) Derated above Ta = 25°C, in the proportion of 11.2mW/°C.

**RECOMMENDED POWER SUPPLY VOLTAGE**

CHARACTERISTIC	SYMBOL	MIN.	TYP.	MAX.	UNIT
Supply Voltage	VCC	10.8	12	13.2	V

**ELECTRICAL CHARACTERISTICS**(Unless otherwise specified,  $V_{CC} = 12V$ ,  $T_a = 25^\circ C$ )

Power supply current

CHARACTERISTIC	SYMBOL	MIN.	TYP.	MAX.	UNIT
Supply Current	$I_{CC}$	20	30	45	mA

Terminal voltage

No.	ITEM	SYMBOL	MIN.	TYP.	MAX.	UNIT	NOTE
1	$\Delta EHT$	$V_1$	7.5	8.0	8.5	V	—
2	EW-OUT	$V_2$	5.8	6.1	6.4		—
3	$V_{CC}$ (12V)	$V_3$	—	12.0	—		Terminal = $V_{CC}$ (12.0V)
4	EW-FB	$V_4$	—	12.0	—		Terminal = $V_{CC}$ (12.0V)
5	GND	$V_5$	—	0.0	—		Terminal = GND
6	V.FB	$V_6$	2.0	2.4	2.8		—
7	N.C.	$V_7$	—	0.0	—		Terminal = GND
8	V.OUT	$V_8$	2.8	3.5	4.3		—
9	SDA	$V_9$	4.8	5.1	5.4		—
10	SCL	$V_{10}$	4.8	5.1	5.4		—
11	N.C.	$V_{11}$	—	0.0	—		Terminal = GND
12	I <sup>2</sup> L GND	$V_{12}$	—	0.0	—		Terminal = GND
13	V.IN	$V_{13}$	—	0.0	—		Terminal = GND
14	T.C.	$V_{14}$	3.7	4.0	4.3		—
15	V.RAMP	$V_{15}$	3.7	4.0	4.3		—
16	V.AGC	$V_{16}$	—	0.0	—		Terminal = GND

(Note) Data : Preset

AC CHARACTERISTICS

No.	ITEM	SYM-BOL	BUS CONTROL DATA				TEST METHOD	MIN.	TYP.	MAX.	UNIT
1	Vertical Trigger Input Threshold Voltage	V <sub>TH13</sub>	02	03	04	05	<ul style="list-style-type: none"> <li>Change the height of trigger pulse given to TP13, and measure the time pulse height when a timing pulse is output.</li> </ul> <p>(*) All data are preset.</p>	0.7	1.0	1.4	V
			40	10	00	08					
			06	07	08	09					
			00	20	00	00					
			0A	0B	0C						
			20	00	00						
2	Clamp Voltage At TP14	V <sub>H14</sub>	02	03	04	05	<ul style="list-style-type: none"> <li>Give the trigger pulse to TP13. (Pulse width : 640µs, cycle : 20ms, Low level : 0V, High level : 3V).</li> <li>Observe the wave shape at TP14.</li> </ul>	3.7	4.0	4.2	V
			40	10	00	08					
			06	07	08	09					
			00	20	00	00					
			0A	0B	0C						
			20	00	00						
3	Threshold Voltage I At TP14	V <sub>M14</sub>	02	03	04	05	<ul style="list-style-type: none"> <li>Same as No.2.</li> <li>Observe the wave shape at TP14 and TP15.</li> </ul> <p>V. RAMP Charging start point</p>	2.8	3.0	3.2	V
			40	10	00	08					
			06	07	08	09					
			00	20	00	00					
			0A	0B	0C						
			20	00	00						

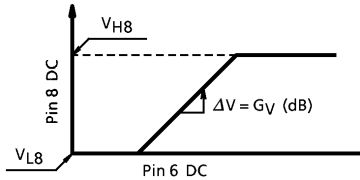

No.	ITEM	SYM-BOL	BUS CONTROL DATA				TEST METHOD	MIN.	TYP.	MAX.	UNIT
4	Threshold Voltage II At TP14	V <sub>L14</sub>	02	03	04	05	<ul style="list-style-type: none"> <li>• Same as No.3.</li> </ul>	0.9	1.0	1.1	V
			40	10	00	08					
			06	07	08	09					
			00	20	00	00					
			0A	0B	0C						
			20	00	00						
5	Vertical Ramp Pulse Amplitude	V <sub>P15</sub>	02	03	04	05	<ul style="list-style-type: none"> <li>• Measure the vertical ramp pulse amplitude at TP15.</li> </ul>  <p>(*) All data are preset.</p>	1.9	2.0	2.1	V <sub>p-p</sub>
			40	10	00	08					
			06	07	08	09					
			00	20	00	00					
			0A	0B	0C						
			20	00	00						
6	Vertical Amplifier Gain	G <sub>V</sub>	02	03	04	05	<ul style="list-style-type: none"> <li>• Give no pulse to TP13.</li> <li>• Connect an external power supply to TP6.</li> <li>• Measure the voltage of TP8 when the voltage of TP6 is changed from 0V to 6V.</li> </ul> 	22	26	30	dB
			40	10	00	08					
			06	07	08	09					
			00	20	00	00					
			0A	0B	0C						
			20	00	00						

No.	ITEM	SYM-BOL	BUS CONTROL DATA				TEST METHOD	MIN.	TYP.	MAX.	UNIT
7	Vertical Amplifier Max. Output Voltage	V <sub>H8</sub>	02	03	04	05	<ul style="list-style-type: none"> <li>• Same as No.6.</li> <li>(*) All data are preset.</li> </ul>	2.9	3.6	4.5	V
			40	10	00	08					
			06	07	08	09					
			00	20	00	00					
			0A	0B	0C						
			20	00	00						
8	Vertical Amplifier Min. Output Voltage	V <sub>L8</sub>	02	03	04	05	<ul style="list-style-type: none"> <li>• Same as No.6.</li> </ul>	0	0	0.3	V
			40	10	00	08					
			06	07	08	09					
			00	20	00	00					
			0A	0B	0C						
			20	00	00	00					
9	Vertical Amplifier Max. Output Current	I <sub>max8</sub>	02	03	04	05	<ul style="list-style-type: none"> <li>• Same as No.6.</li> <li>• Measure the current between TP8 and GND when the voltage of TP6 is 6V.</li> </ul>	20	40	—	mA
			40	10	00	08					
			06	07	08	09					
			00	20	00	00					
			0A	0B	0C						
			20	00	00						

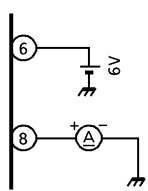

(\*) All data are preset.

No.	ITEM	SYM-BOL	BUS CONTROL DATA				TEST METHOD	MIN.	TYP.	MAX.	UNIT	
10	Vertical Saw Wave Amplitude	V <sub>P6</sub>	02	03	04	05	<ul style="list-style-type: none"> <li>• Same as No.2.</li> <li>• Measure the amplitude of saw wave at TP6.</li> <li>(*) All data are preset.</li> </ul>	1.7	1.9	2.2	V <sub>p-p</sub>	
			40	10	00	08						
			06	07	08	09						
			00	20	00	00						
			0A	0B	0C							
			20	00	00							
11	Vertical Amplitude Variable Range	V <sub>PH</sub>	02	03	04	05	<ul style="list-style-type: none"> <li>• Same as No.10.</li> <li>• Measure the amplitude V<sub>P6</sub> (00) at TP6 when the data of sub address (02) is turned to (00).</li> <li>• Measure the amplitude V<sub>P6</sub> (3F) at TP6 when the data of sub address (02) is turned to (00).</li> </ul> $V_{PH} = \pm \frac{V_{P6} (3F) - V_{P6} (00)}{V_{P6} (3F) + V_{P6} (00)} \times 100\%$	+45 -45	+48 -48	+51 -51	%	
			7F	10	00	08						
			00	06	07	08						09
			00	20	00	00						
			0A	0B	0C							
			20	00	00							
12	Vertical Linearity Max. Correction	V <sub>ℓ</sub>	02	03	04	05	<ul style="list-style-type: none"> <li>• Turn it to (3F) the data of sub address (08) and adjust the data of sub address (0A) for making the shape of parabolic wave of TP4 symmetrical.</li> <li>• Turn it to (00) the data of sub address (08).</li> <li>• Measure V<sub>1</sub> (10) and V<sub>2</sub> (10) at TP6 when the data of sub address (03) is (10).</li> <li>• Similarly measure V<sub>1</sub> (00), V<sub>2</sub> (CC), V<sub>1</sub> (1F) and V<sub>2</sub> (1F). (00) and (1F) are the data of sub address (08).</li> </ul> $V_{\ell} = \pm 100 \times \frac{V_1 (00) - V_1 (1F) + V_2 (1F) - V_2 (00)}{2 \times (V_1 (10) + V_2 (10))}$	+10.0 -10.0	+12.5 -12.5	+15.0 -15.0	%	
			40	1F	00	08						
			06	07	08	09						
			00	20	00	00						
			0A	0B	0C							
			Adjust	00	00							

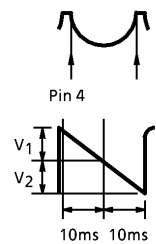

No.	ITEM	SYM-BOL	BUS CONTROL DATA				TEST METHOD	MIN.	TYP.	MAX.	UNIT
13	Max. Of Vertical S Correction	V <sub>S</sub>	02	03	04	05	<ul style="list-style-type: none"> <li>• Same as No.12.</li> <li>• Measure the amplitude V<sub>S6</sub>(00) at TP6 when the data of sub address (04) is (00).</li> <li>• Measure the amplitude V<sub>S6</sub>(1F) at TP6 when the data of sub address (04) is (00).</li> </ul> $V_S = \frac{V_{S6}(00) - V_{S6}(1F)}{V_{S6}(00)} \times 100 (\%)$	20	24	28	%
			40	10	1F	08					
			06	07	08	09					
			00	20	00	00					
			0A	0B	0C						
Adjust	00	00									
14	Max. Of Vertical f Correction	V <sub>f</sub>	02	03	04	05	<ul style="list-style-type: none"> <li>• Same as No.13.</li> <li>• Measure the amplitude V<sub>f6</sub>(00) at TP6 when the data of sub address (0C) is (00).</li> <li>• Measure the amplitude V<sub>f6</sub>(0F) at TP6 when the data of sub address (0C) is (0F).</li> </ul> $V_f = \frac{V_{f6}(0F) - V_{f6}(00)}{V_{f6}(00)} \times 100 (\%)$	3	—	—	%
			40	10	00	08					
			06	07	08	09					
			00	20	00	00					
			0A	0B	0C						
Adjust	00	0F	00								
15	Vertical NF Center Voltage	V <sub>C</sub>	02	03	04	05	<ul style="list-style-type: none"> <li>• Same as No.12.</li> <li>• Observe the wave shape at TP6.</li> </ul>	3.8	4.1	4.4	V
			40	10	00	08					
			06	07	08	09					
			00	20	00	00					
			0A	0B	0C						
Adjust	00	00									

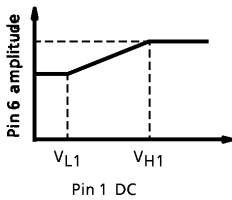
No.	ITEM	SYM-BOL	BUS CONTROL DATA				TEST METHOD	MIN.	TYP.	MAX.	UNIT
16	Vertical NF DC Variation	VDC	02	03	04	05	<ul style="list-style-type: none"> <li>• Same as No.15.</li> <li>• Measure the vertical NF center voltage <math>V_C(00)</math> when the data of sub address (05) is (00).</li> <li>• Measure the vertical NF center voltage <math>V_C(0F)</math> when the data of sub address (05) is (0F).</li> </ul> $V_{DC} = \pm \frac{V_C(0F) - V_C(00)}{2} (V)$	± 720	± 800	± 880	mV
			40	10	00	0F					
			06	07	08	09					
			00	20	00	00					
			0A	0B	0C						
			Adjust	00	00						
17	Vertical Amplitude EHT Correction	VEHT	02	03	04	05	<ul style="list-style-type: none"> <li>• Same as No.12.</li> <li>• Connect an external power supply to TP1 and turn its voltage to 0V.</li> <li>• Measure the amplitude <math>V_{EHT}(00)</math> at TP6 when the data of sub address (06) is (00).</li> <li>• Measure the amplitude <math>V_{EHT}(0F)</math> at TP6 when the data of sub address (06) is (0F).</li> </ul> $V_{EHT} = \frac{V_{EHT}(00) - V_{EHT}(0F)}{V_{EHT}(00)} \times 100 (\%)$	8	9	10	V
			40	10	00	08					
			06	07	08	09					
			0F	20	00	00					
			0A	0B	0C						
			Adjust	00	00						
18	EHT Input Dynamic Range I	V <sub>H1</sub>	02	03	04	05	<ul style="list-style-type: none"> <li>• Same as No.17.</li> <li>• Change it from 1V to 7V the voltage of the external power supply connected with TP1.</li> <li>• At this time, measure the variation of amplitude at TP6.</li> </ul> 	6.0	6.5	7.0	V
			40	10	00	08					
			06	07	08	09					
			0F	20	00	00					
			0A	0B	0C						
			Adjust	00	00						

No.	ITEM	SYM-BOL	BUS CONTROL DATA				TEST METHOD	MIN.	TYP.	MAX.	UNIT
19	EHT Input Dynamic Range II	VL1	02	03	04	05	● Same as No.18.	1.3	1.8	2.3	V
			40	10	00	08					
			06	07	08	09					
			0F	20	00	00					
			0A	0B	0C						
			Adjust	00	00						
20	E-W NF Max. DC (Picture Width)	—	02	03	04	05	● Same as No.12. ● Measure the voltage at TP4.	6.8	7.4	8.0	V
			40	10	00	08					
			06	07	08	09					
			00	00	00	00					
			0A	0B	0C						
			Adjust	00	00						
21	E-W NF Min. DC (Picture Width)	VL4	02	03	04	05	● Measure the voltage at TP4.	1.4	1.5	1.7	V
			40	10	00	08					
			06	07	08	09					
			00	3F	00	00					
			0A	0B	0C						
			Adjust	00	00						

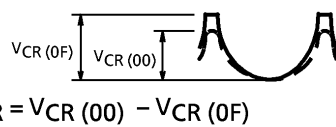
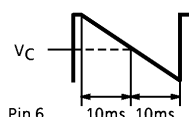
No.	ITEM	SYM-BOL	BUS CONTROL DATA				TEST METHOD	MIN.	TYP.	MAX.	UNIT
22	E-W NF Max. Parabolic Correction (Parabola)	V <sub>PB</sub>	02	03	04	05	<ul style="list-style-type: none"> <li>Give 7V to TP1.</li> <li>Measure the parabolic amplitude at TP4.</li> </ul> 	4.8	5.6	6.6	V <sub>p-p</sub>
			40	10	00	08					
			06	07	08	09					
			00	3F	3F	00					
			0A	0B	0C						
			Adjust	00	00						
23	E-W NF Corner Correction (Corner)	V <sub>CR</sub>	02	03	04	05	<ul style="list-style-type: none"> <li>Give 7V to TP1.</li> <li>Measure the parabolic amplitude at TP4.</li> <li>Measure the amplitude V<sub>CR</sub> (00) when the data of sub address (09) is (00).</li> <li>Measure the amplitude V<sub>CR</sub> (0F) when data of sub address (09) is (0F).</li> </ul>  $V_{CR} = V_{CR}(00) - V_{CR}(0F)$	2.5	3.2	4.1	V <sub>p-p</sub>
			40	10	00	08					
			06	07	08	09					
			00	3F	3F	0F					
			0A	0B	0C						
			Adjust	00	00						
24	Parabolic Symmetry Correction	V <sub>TR</sub>	02	03	04	05	<ul style="list-style-type: none"> <li>Same as No.10.</li> <li>Measure the vertical scan center voltage V<sub>C</sub> (00) at TP6 when the data of sub address (0A) is (00).</li> <li>Measure the vertical scan center voltage V<sub>C</sub> (3F) at TP6 when the data of sub address (0A) is (3F).</li> </ul> $V_{TR} = \pm \frac{V_C(00) - V_C(3F)}{2 \times V_{P6}} \times 100 (\%)$ 	± 3	± 4.5	± 6	%
			40	10	00	08					
			06	07	08	09					
			00	20	00	00					
			0A	0B	0C						
			3F	00	00						
00											

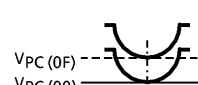
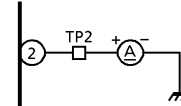
No.	ITEM	SYM-BOL	BUS CONTROL DATA				TEST METHOD	MIN.	TYP.	MAX.	UNIT
25	E-W Parabolic EHT Correction	V <sub>EH1</sub>	02	03	04	05	<ul style="list-style-type: none"> <li>• Same as No.22.</li> <li>• Connect an external power supply to TP1.</li> <li>• Measure the parabolic amplitude V<sub>EH</sub>(7) at TP4 when the voltage of TP1 is 7V.</li> <li>• Measure the amplitude V<sub>EH</sub>(1) when the voltage of TP1 is 1V.</li> </ul> $V_{EH1} = \frac{V_{EH(7)} - V_{EH(1)}}{V_{EH(7)}} \times 100 (\%)$	—	4.7	—	%
			40	10	00	08					
			06	07	08	09					
			00	00	3F	00					
			0A	0B	0C						
			Adjust	00	00						
26	E-W DC EHT Correction	V <sub>EH2</sub>	02	03	04	05	<ul style="list-style-type: none"> <li>• Give 1V to TP1.</li> <li>• Measure the parabolic phase center voltage V<sub>PC</sub>(00) at TP4 when the data of sub address (0B) is (00).</li> <li>• Measure the voltage V<sub>PC</sub>(0F) when the data is (0F).</li> </ul> $V_{EH2} = V_{PC(0F)} - V_{PC(00)}$ 	1.0	1.4	1.8	V
			40	10	00	08					
			06	07	08	09					
			00	3F	3F	00					
			0A	0B	0C						
			Adjust	00 ↑ 0F	00						
27	Max. Of E-W Amplifier Output Current	I <sub>max2</sub>	02	03	04	05	<ul style="list-style-type: none"> <li>• Connect an ampere meter between TP2 and GND.</li> <li>• Measure the current.</li> </ul> 	0.14	0.2	0.27	mA
			40	10	00	10					
			06	07	08	09					
			00	20	00	00					
			0A	0B	0C						
			20	00	00						



(Note) Concerning fall time

When used in actual applications, if the fall time for input pulse becomes greater output may not be generated in some cases, so please take care.

CHARACTERISTIC	TEST METHOD	MIN.	TYP.	MAX.	UNIT
Trigger Input Fall Time	As below	—	1.0	7.6	$\mu\text{s}$

While monitoring the input waveform of Pin 13 oscilloscope, please measure fall time from 10% to 90%.

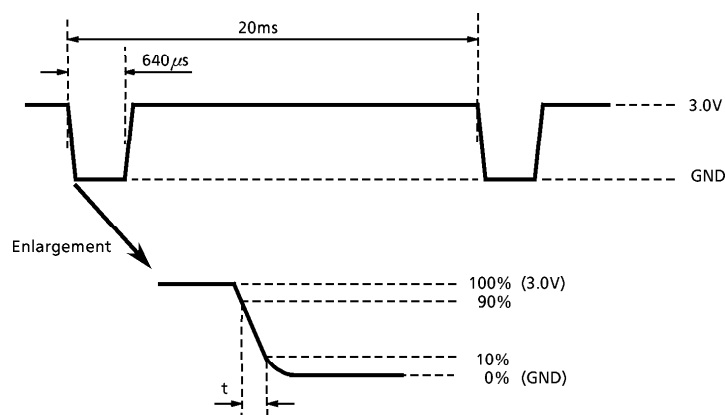
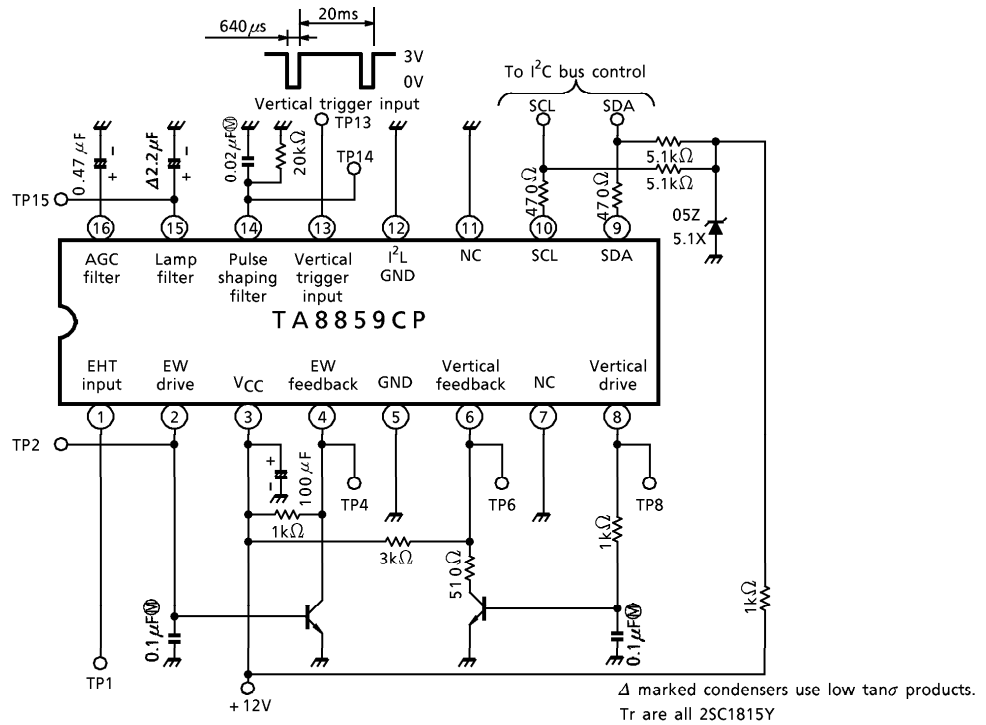
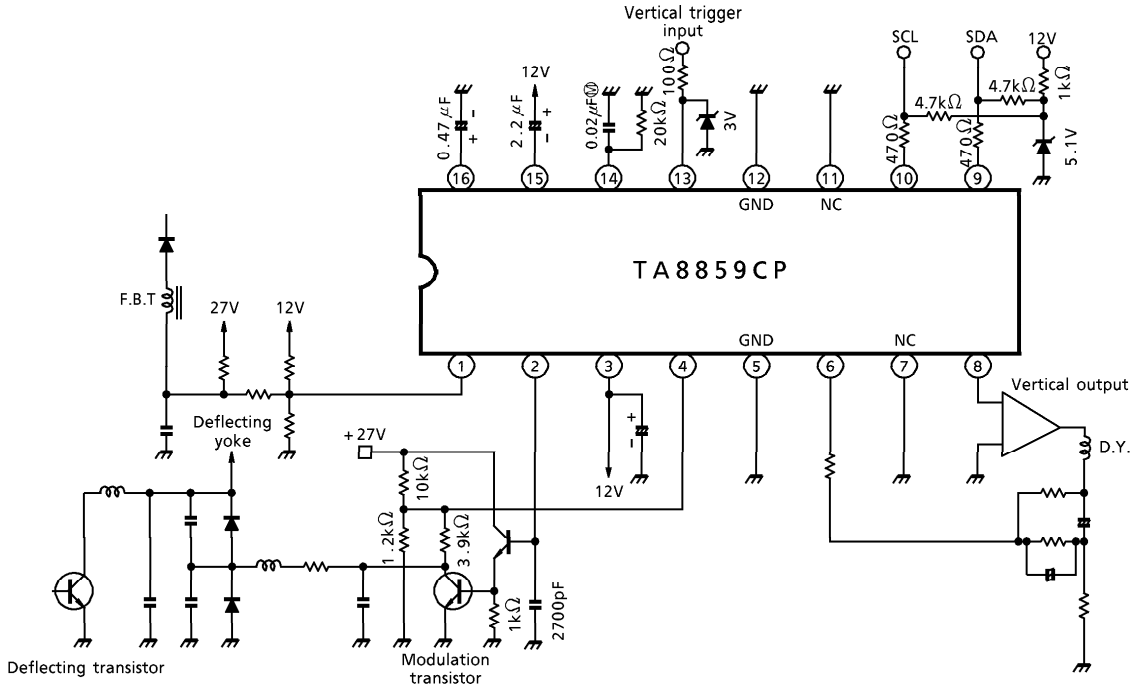

Fig.

TEST CIRCUIT



APPLICATION CIRCUIT



PACKAGE DIMENSIONS  
DIP16-P-300-2.54B

UNIT : mm

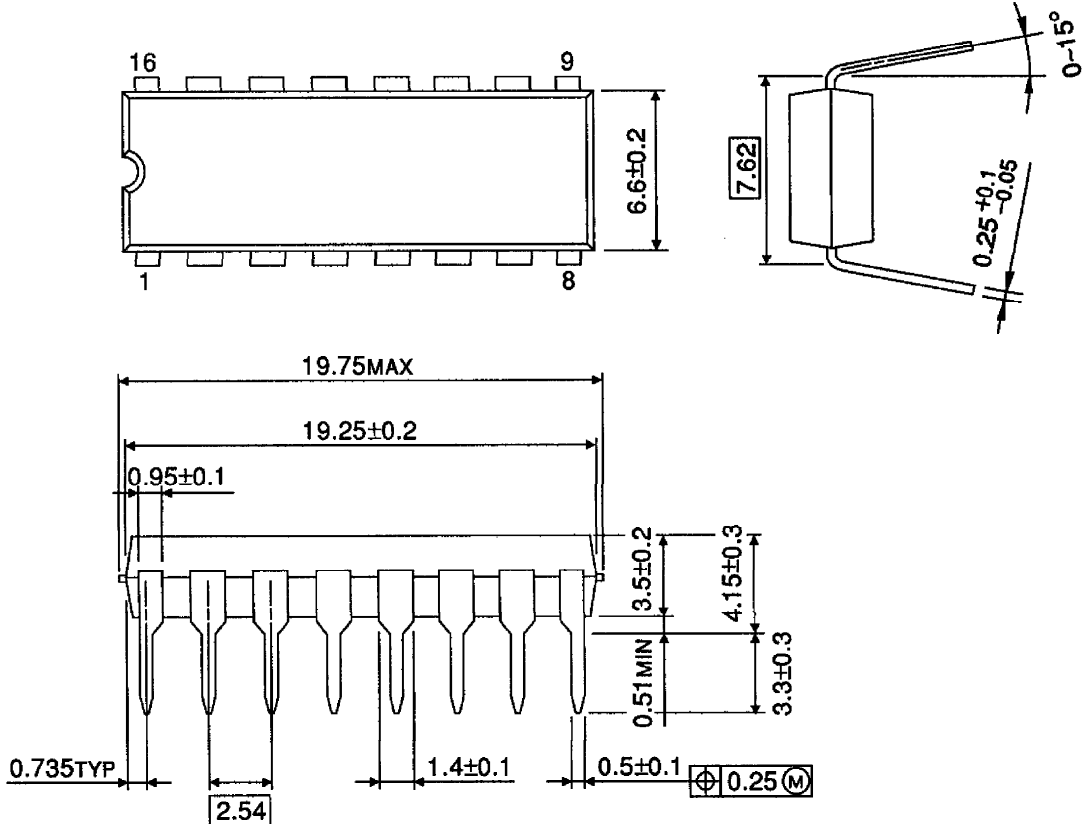

Weight : 1.11g (Typ.)

**RESTRICTIONS ON PRODUCT USE**

000707EBA

- TOSHIBA is continually working to improve the quality and reliability of its products. Nevertheless, semiconductor devices in general can malfunction or fail due to their inherent electrical sensitivity and vulnerability to physical stress. It is the responsibility of the buyer, when utilizing TOSHIBA products, to comply with the standards of safety in making a safe design for the entire system, and to avoid situations in which a malfunction or failure of such TOSHIBA products could cause loss of human life, bodily injury or damage to property. In developing your designs, please ensure that TOSHIBA products are used within specified operating ranges as set forth in the most recent TOSHIBA products specifications. Also, please keep in mind the precautions and conditions set forth in the "Handling Guide for Semiconductor Devices," or "TOSHIBA Semiconductor Reliability Handbook" etc..
- The TOSHIBA products listed in this document are intended for usage in general electronics applications (computer, personal equipment, office equipment, measuring equipment, industrial robotics, domestic appliances, etc.). These TOSHIBA products are neither intended nor warranted for usage in equipment that requires extraordinarily high quality and/or reliability or a malfunction or failure of which may cause loss of human life or bodily injury ("Unintended Usage"). Unintended Usage include atomic energy control instruments, airplane or spaceship instruments, transportation instruments, traffic signal instruments, combustion control instruments, medical instruments, all types of safety devices, etc.. Unintended Usage of TOSHIBA products listed in this document shall be made at the customer's own risk.
- The products described in this document are subject to the foreign exchange and foreign trade laws.
- The information contained herein is presented only as a guide for the applications of our products. No responsibility is assumed by TOSHIBA CORPORATION for any infringements of intellectual property or other rights of the third parties which may result from its use. No license is granted by implication or otherwise under any intellectual property or other rights of TOSHIBA CORPORATION or others.
- The information contained herein is subject to change without notice.