



INTEGRATED CIRCUIT

TECHNICAL DATA

TA7243P

TOSHIBA BIPOLAR LINEAR INTEGRATED CIRCUIT
SILICON MONOLITHIC

TENTATIVE

TV SOUND IF AND AUDIO OUTPUT SUBSYSTEM

The TA7243P combines the sound IF and audio Output Subsystem on a single monolithic integrated circuit to provide a Television Sound System.

This device includes a multistage IF amplifier-limiter, and FM detector with electronic volume control, and an audio power amplifier that is designed to drive an 8, 16, 32Ω speaker.

FEATURES

- . Nominal Power Output : 3W
- . Power Amplifier with Current Limiting and Thermal Shutdown.
- . Wide Power Supply Range : 16V to 30V
- . Low Quiescent Current : 33mA Typ.
- . Limiting Sensitivity : 300μV Typ.
- . Excellent AM Rejection : 50dB Typ.
- . Differential Peak Detector-Requires One Tuned Coil
- . Optional Unattenuated Audio Output
- . Optional Power Supply Ripple By-pass

Unit in mm

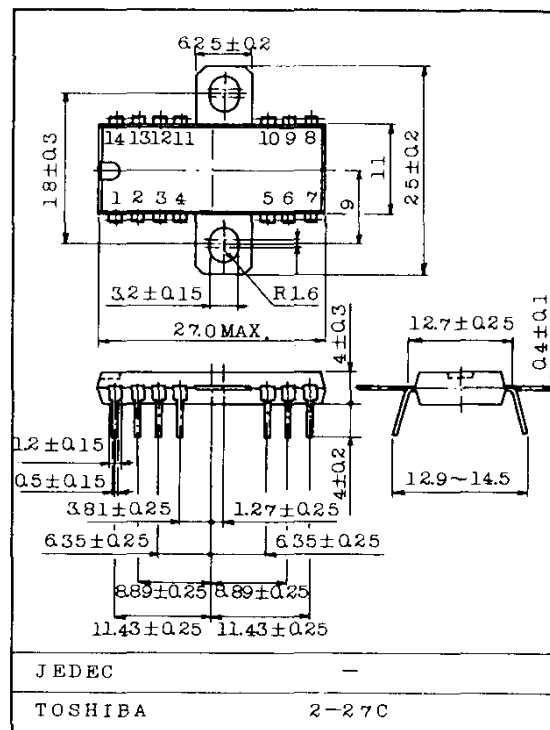

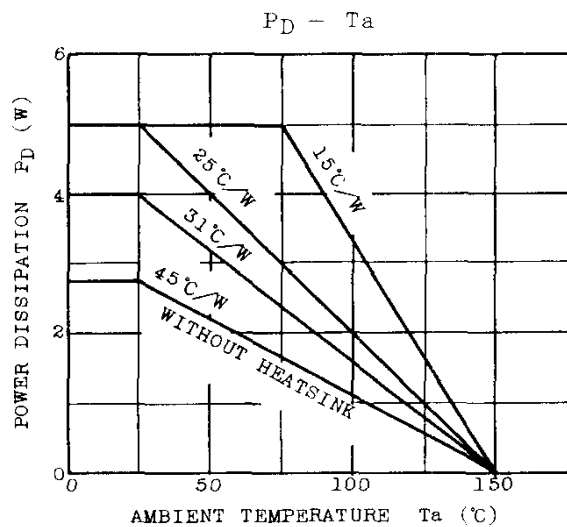
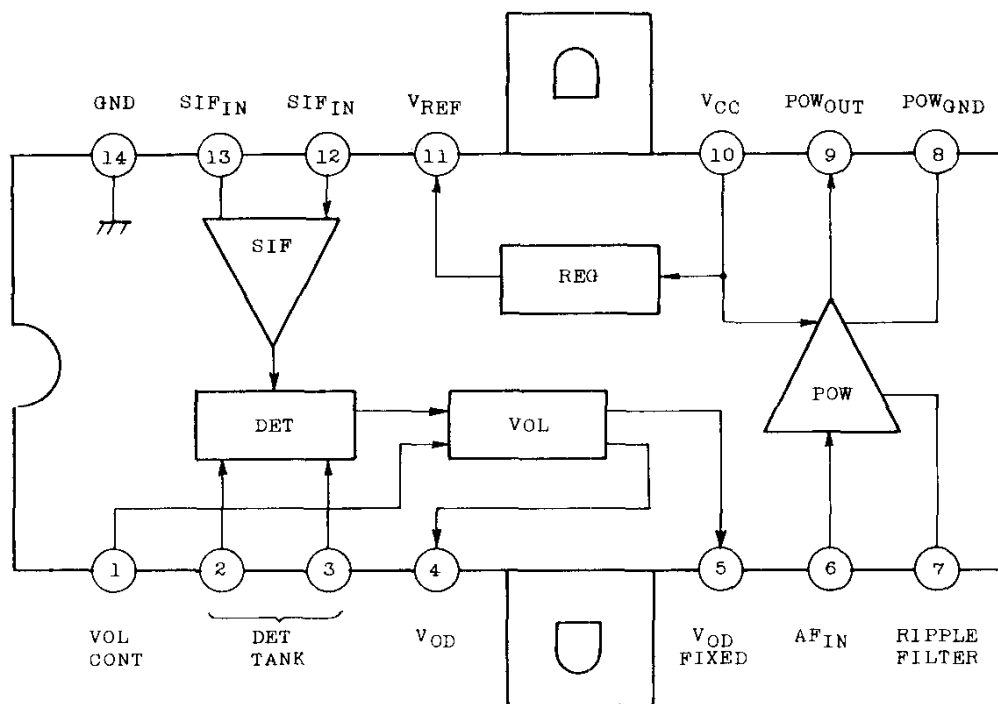

Fig. 1 TA7243P BLOCK DIAGRAM



MAXIMUM RATINGS (Ta=25°C)

CHARACTERISTIC	SYMBOL	RATING	UNIT
Supply Voltage	V _{CC}	33	V
Input Signal Level	e _{in}	±3	V
Power Dissipation (Ta=75°C) with Infinite Heatsink	P _D	5.0	W
Operating Temperature	T _{opr}	-20 ~ 75	°C
Storage Temperature	T _{stg}	-20 ~ 150	°C

ELECTRICAL CHARACTERISTICS (Ta=25°C, V_{CC}=30V, Reffer to Test Circuit)

CHARACTERISTIC	SYMBOL	TEST CIR-CUIT	TEST CONDITION	MIN.	TYP.	MAX.	UNIT
Quiescent Current	I _{CCQ}	2	P _O =0	15	33	50	mA
Detector Output Voltage (Pin 4)	V _{OD4}	2	Note 1	-	0.45	1.4	V _{rms}
Total Harmonic Distortion (Pin 4)	THD4	2	Note 1	-	0.8	2.0	%
Detector Output Voltage (Pin 5)	V _{OD5}	2	Note 2	-6	-1.5	-	dB
AM Rejection	AMR	2	Note 3	38	50	-	dB
Volume Control -20dB	ATT20	2	Note 4	-23	-20	-15	dB
Volume Control -40dB	ATT40	2	Note 4	-44	-40	-33	dB
Maximum Attenuation	ATT MAX	2	Note 4	-	-70	-	dB
Limitting Sensitivity	V _{lim}	2	Note 5	-	300	-	μV _{rms}
Audio Amplifier Voltage Gain	G _v	2	f=1kHz Pin 6 to Pin 9	-	35	-	dB
Power Output	P _O	2	f=1kHz, THD=10%	3	-	-	W
Refference Voltage	V _{ref}	2	Measure Pin 11	5.4	6.0	6.6	V



Test temperature is 25°C at a supply voltage of 30±1 volts.

Switch S₁ is closed, S₂ in position "1", S₃ in position "3", and S₅ in position "1" unless otherwise specified.

Alignment Procedure

1. Remove input signal, set S₄ in position "1".
2. Read DC voltage on Pin 4.
3. Apply a 50mV_{rms} 4.5MHz CW signal to input.
4. Adjust detector coil so the DC voltage on Pin 4 is equal to the voltage read in step 2.

Note 1

V_i: f=4.5MHz 25kHz deviation 400Hz 50mV_{rms} at Pin 12. S₂ in position "2", S₃ in position "1". Measure V₀.

Note 2

V_i, S₂: Same as Note 1
S₃ in position "2", S₅ in position "2". Measure V₀

Note 3

Same as Note 1, measure V₀ (V_{FM})
Then change modulation to 30% AM, measure V₀ (V_{AM})
AMR=20 × log (V_{FM}/V_{AM}) (dB)

Note 4

Same as Note 1
Set S₄ in position "2", measure V₀(ATT2)
ATT20=20 × log (V₀(ATT2)/V_{0D}) (dB)
Set S₄ in position "3", measure V₀(ATT3)
ATT40=20 × log (V₀(ATT3)/V_{0D}) (dB)
Set S₄ in position "4", measure V₀(ATT4)
ATT MAX=20 × log (V₀(ATT4)/V_{0D}) (dB)

Note 5

Same as Note 1, then reduce input signal so that the output voltage on Pin 4 will be -3dB of the V_{0D}. Measure signal level on Pin 12.



INTEGRATED CIRCUIT

TECHNICAL DATA

TA7243P

AMR CHARACTERISTICS

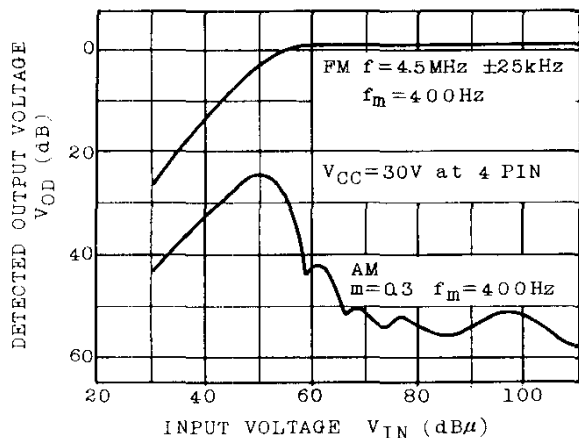

$\Delta f - V_{OD4}, \text{THD}$

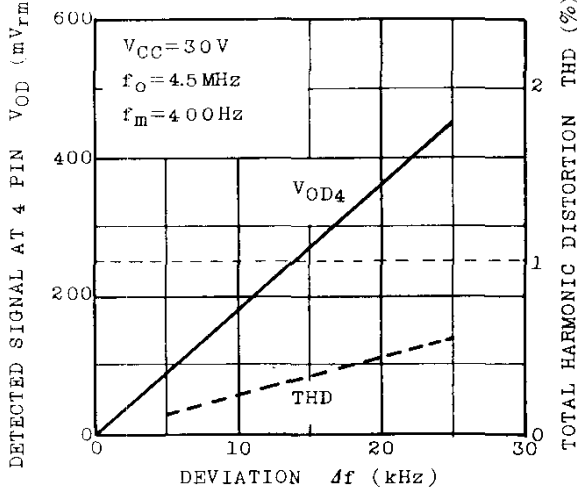

ELECTRONIC VOLUME CONTROL TYP

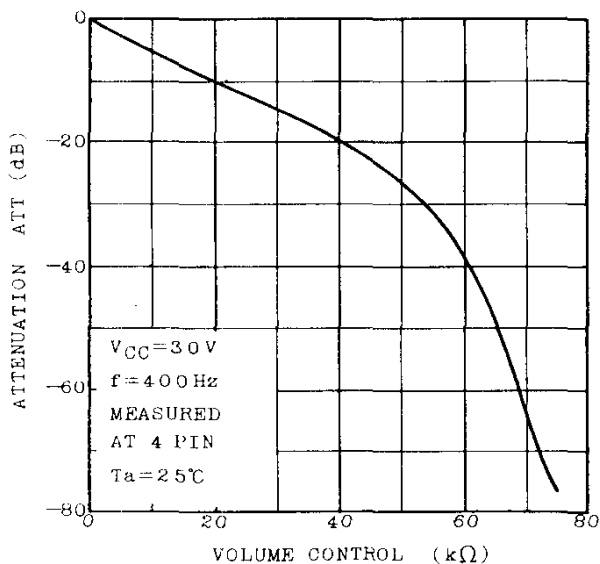

$f - G_v, \text{THD}, I_{CC}$

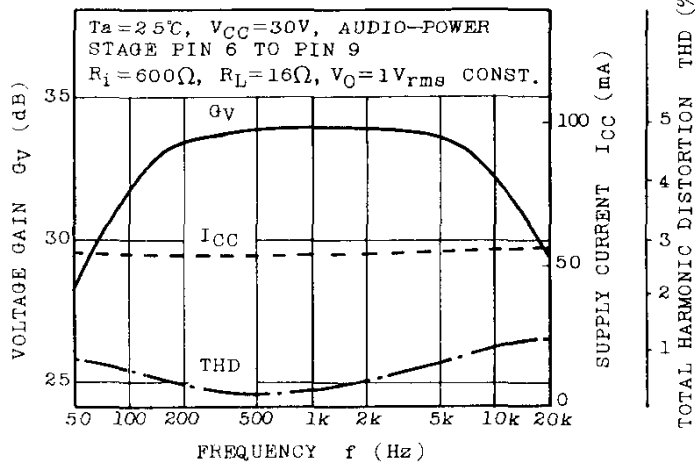



INTEGRATED CIRCUIT

TECHNICAL DATA

TA7243P

