

S P E C I F I C A T I O N

SanKen Hybrid IC Voltage Regulator STR30000 Series

Date : December 2, 1986
 Specification No. : SSE-15051

1. Features:
- A. Hybrid IC Voltage Regulator incorporated triple diffused planar darlington transistor
 - B. For Line-Operated CTV
 - C. Fixed Output Voltage

2. Equivalent Circuit

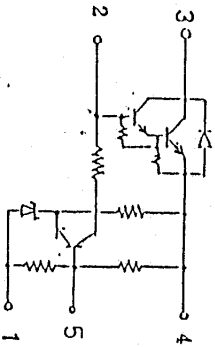

- 1. Common
 - 2. Base
 - 3. Input
 - 4. Output
 - 5. Blank
- * STR30110 has pin No.5 for output voltage adjustment.

3. Outline Drawings, Marking and Pin connections are as per attached Fig.-1.

4. The type number, voltage and lot number shall be legitimately marked by white color.

5. Absolute Maximum Ratings

Description	Symbol	Unit	Ratings
Maximum Peak Input Voltage	V_{IN}	V	200
Maximum Output Current	I_O	A	1.0
Maximum Power Dissipation	P_D	W	27 ($T_c=100^{\circ}C$)
Operating Temperature	T_{op}	$^{\circ}C$	-20 ~ +125 (T_c)
Storage Temperature	T_{stg}	$^{\circ}C$	-30 ~ +125
Junction Temperature of Power Transistor	T_j	$^{\circ}C$	+150 Max

*1. Recommended Case Temperature : $T_c(op)=100^{\circ}C$



SANKEN ELECTRIC COMPANY, LTD.

6. Electrical Characteristics $T_a = 25^\circ\text{C}$

Description	Conditions	Ratings
Fixed Output Voltage (Measuring Circuit 1 and 2)	See the Table	See the Table **
Line Regulation (Measuring Circuit 1)	"	"
Load Regulation (Measuring Circuit 1)	"	"
Output Voltage Temperature Coefficient	"	"
In-Out Saturation Voltage ($V_{CE(sat)}$)	$I_C=1.0A, I_B=10mA$	1.5V Max
In-Out Breakdown Voltage (V_{CEO})	$I_{CEO}=10mA, I_B=0A$	200V Min
DC Current Gain (h_{FE})	$I_C=1.0A, V_{CE}=4V$	1,500 ~ 6,500
Thermal Resistance ($R_{th(j-c)}$)	Junction and Copper plate of IC	1.8°C/W
In-Out Leak Current (I_{CEO})	V_{CE} (Pin 3-4)=200V P_{IH} 1, 2 and 5 open	100 μ A Max
Reverse Surge Current Between Pin 4 and 2	$t=65msec$	300mA Max

** The fixed output voltage is to be measured at 5 seconds passed after power switch turned on. When the output voltage at the measuring circuit 1 is deviated from the specified, it is to be judged by the measuring circuit 2.

Suggested Silicone Grease

C746: SHIN-ETSU CHEMICAL INDUSTRY CO., LTD.
C747: SHIN-ETSU CHEMICAL INDUSTRY CO., LTD.
YG6260: TOSHIBA SILICONE CO., LTD.
SCI02: TORAY SILICONE CO., LTD.

Table

Description		Type No.	STR30110	STR30112	STR30113	STR30115	STR30120	STR30123	STR30125	STR30130	STR30134	STR30135
1	Specified Voltage		110±0.8V	112±0.8V	113±0.8V	115±0.8V	120±0.8V	123±0.8V	125±0.8V	130±0.8V	134±0.8V	135±0.8V
	Conditions 1 (Measuring Circuit 2)		$I_{IN} = 5.9 \text{ mA}$				$I_{IN} = 7.2 \text{ mA}$			$I_{IN} = 6.9 \text{ mA}$		
	Conditions 2 (Measuring Circuit 1)		$V_{IN} = 134 \text{ V (DC)}, I_o = 0.5 \text{ A}$				$V_{IN} = 161 \text{ V (DC)}, I_o = 0.5 \text{ A}$					
2	Specified Regulation		$\Delta 2.4 \text{ V MAX}$									
	Conditions (Measuring Circuit 1)		$V_{IN} = 125 \sim 150 \text{ V (DC)}$ $I_o = 0.5 \text{ A}$				$V_{IN} = 145 \sim 170 \text{ V (DC)}$ $I_o = 0.5 \text{ A}$			$V_{IN} = 150 \sim 175 \text{ V (DC)}$ $I_o = 0.5 \text{ A}$		
3	Specified Regulation		$\Delta 0.5 \text{ V MAX}$									
	Conditions (Measuring Circuit 1)		$V_{IN} = 134 \text{ V (DC)}$ $I_o = 0.25 \sim 0.5 \text{ A}$				$V_{IN} = 161 \text{ V (DC)}$ $I_o = 0.25 \sim 0.5 \text{ A}$					
4	Specified Coefficient		$\pm 0 \text{ mV}/^\circ\text{C typ}$									
	Conditions (Measuring Circuit 1)		$V_{IN} = 134 \text{ V (DC)}, I_o = 0.5 \text{ A}$ $I_o = -20 \sim 100 \text{ }^\circ\text{C}$				$V_{IN} = 161 \text{ V (DC)}, I_o = 0.5 \text{ A}$ $T_o = -20 \sim 100 \text{ }^\circ\text{C}$					
Value of resistors used in Measuring Circuit 1			$R_3 = 10 \text{ K}\Omega$ $R_4 = 220 \text{ K}\Omega$		$R_3 = 10 \text{ K}\Omega$ $R_4 = 330 \text{ K}\Omega$		$R_3 = 12 \text{ K}\Omega$ $R_4 = 220 \text{ K}\Omega$			$R_3 = 12 \text{ K}\Omega$ $R_4 = 330 \text{ K}\Omega$		

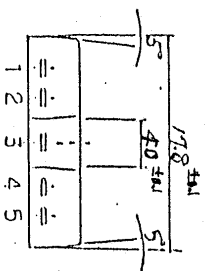
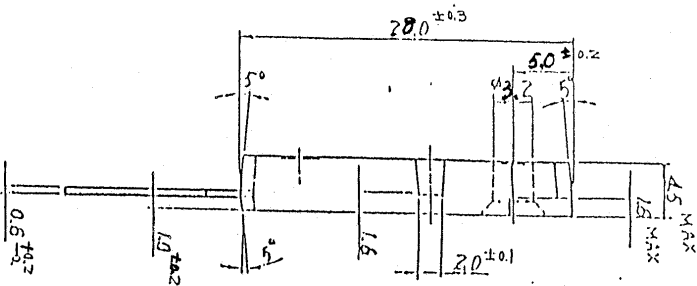
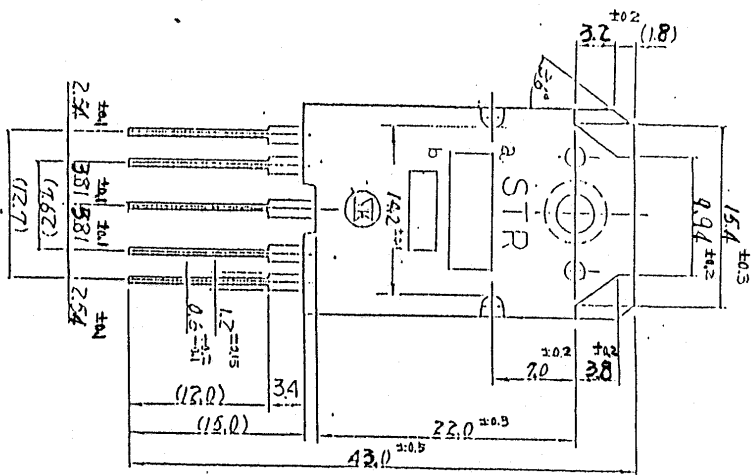

- a. Type number
- b. Lot number
- 1st character for year
- 2nd character for month
- Jan ~ Sept: 1 ~ 9
- October : O
- November : N
- December : D
- 3rd and 4th characters for date : 01 ~ 31

- 1. Common (Ground)
 - 2. Base Drive
 - 3. Input
 - 4. Output
 - 5. Blank
- * STR30110 has pin No.5 for output voltage adjustment.

4	4 短	短	短	短		Outline Drawings for Plastic Molded STR (2GR)
3	3 短	短	短	短		
2	2 短	短	短	短		
1	1 短	短	短	短		
7						