



GENERAL DESCRIPTION

SM3015 is a multi-function Fan Controller CMOS IC that can be applied to a variety of consumer products. It has an elastic function like MCU but does not need programming, user can just write a MASK form.

SM3015 has three or four wind modes; normal, rhythm and sleep-rhythm wind or normal, rhythm, sleep-normal and sleep-rhythm, the operation pattern of rhythm and sleep modes can be set by user.

Many kinds of timer setting and two swing head control that include micro-swing output can be chosen by user to tune the swing head angle.

Memory or non-memory function is available; the Speed, Mode, Swing functions will operate as last state in memory type.

Supports two-bit customer codes to distinguish different models.

FEATURES

- * High performance CMOS technology.
- * Rhythm wind or Normal wind for SLEEP mode can be chosen.
- * Two to three-wind grade control in wind modes.
- * Memory start-up function option.
- * Many types of timer setting on three or four steps and ladder adder or non-ladder adder.
- * Two swing head control, micro-swing output can be chosen by MASK option.
- * SPEED or ON/OFF key can enable fan controller.
- * 16 or 32 patterns per cycle of rhythm/sleep mode, each pattern has 2.5 sec.
- * Panel control or pair with SM5021B for an infrared Remote Fan Controller.
- * 16/18/20/22/24 pin plastic DIP package.
- * Three types of sleep hold time by SLT key: 0.5hr/1hr/2hr.
- * 32.768KHz/455KHz oscillator option.

APPLICATIONS

- * Electronic Fan
- * Heater Fan
- * Air-Cleaner
- * Dehumidifier
- * Humidifier
- * Kitchen Exhaust
- * Dish Dryer
- * Wall Fan

PIN ASSIGNMENTS (TOP VIEW)

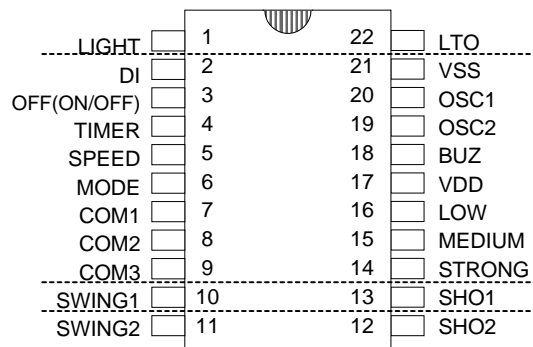

SM3015A 16/18/20/22PIN

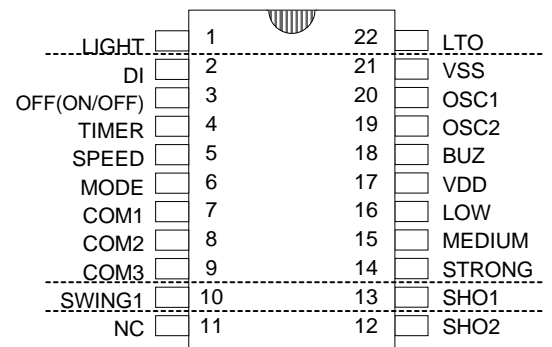

SM3015B 16/18/20/22PIN



PIN ASSIGNMENT (TOP VIEW)

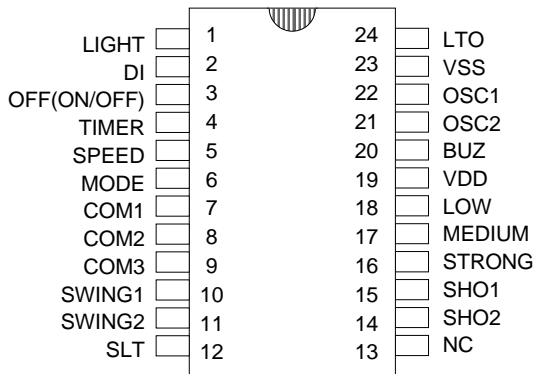

SM3015C 24PIN

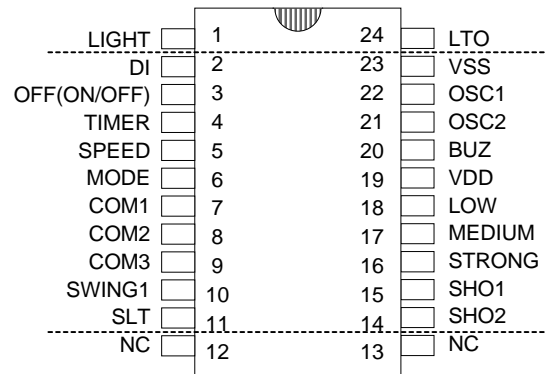

SM3015D 20/24PIN

PANEL DISPLAY

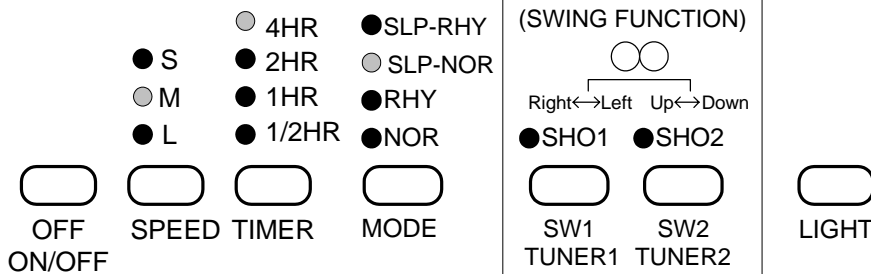

SM3015A TYPE

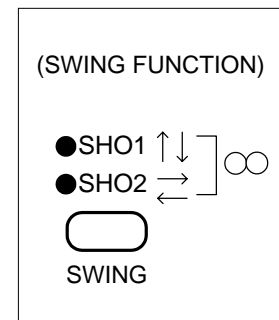

SM3015B TYPE

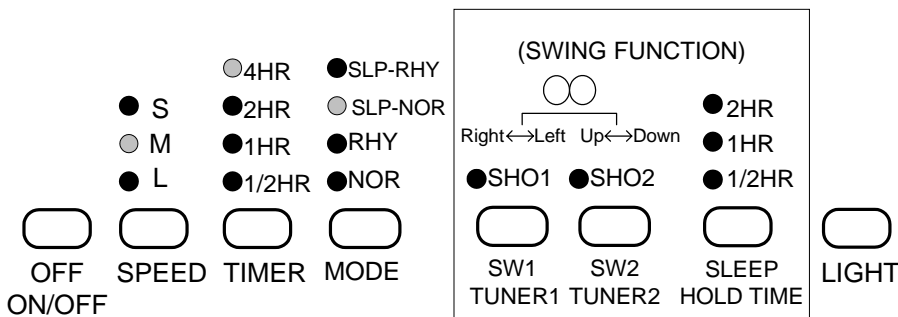

SM3015C TYPE

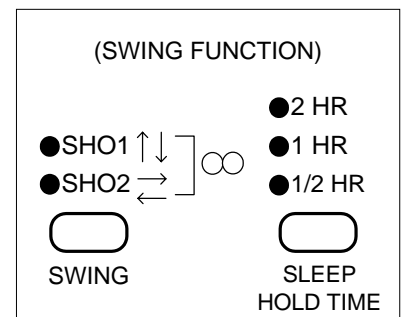

SM3015D TYPE

* Note: "●" Functions can be chosen by MASK or bonding option.



BLOCK DIAGRAM

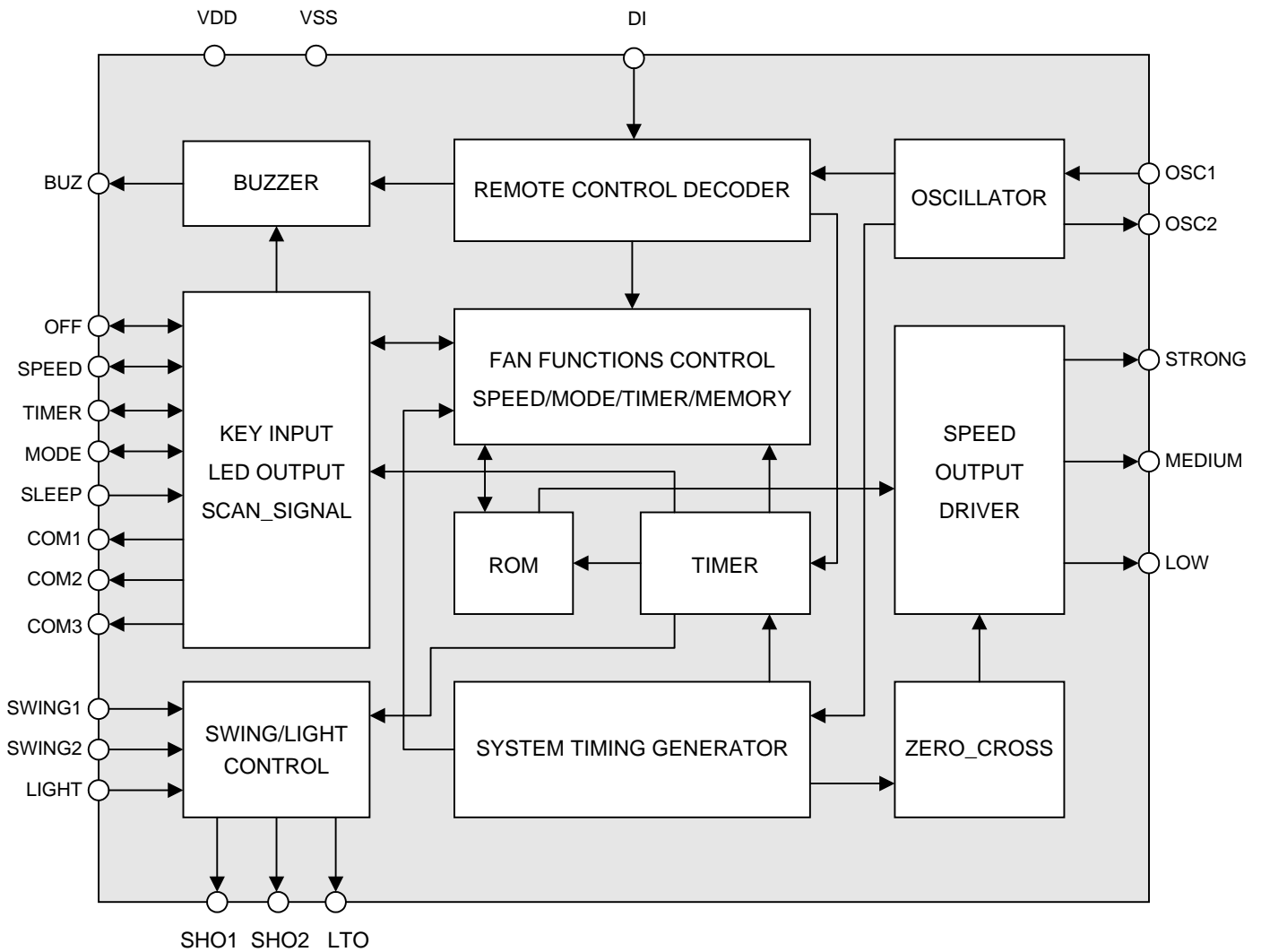

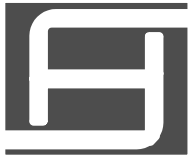

PIN DESCRIPTIONS

No.	Pin Name	I/O	Function
1	LIGHT	I	Light control input
2	DI	I	Remote control input
3	ON_OFF/OFF	I/O	On-Off or Off function control input
4	TIMER	I/O	Timer setting input
5	SPEED	I/O	Wind grade selection input
6	MODE	I/O	Wind mode selection input
7	COM1	O	LED scanning common pin / Customer code
8	COM2	O	LED scanning common pin / Customer code
9	COM3	O	LED scanning common pin
10	SWING1	I	Swing head control input / Customer code
11	SWING2	I	Swing head control input
12	SLT	I/O	Sleep time control input
13	NC		No connection
14	SHO2	O	Swing head / tuner pulse output
15	SHO1	O	Swing head / tuner pulse output
16	STRONG	O	Wind speed control output
17	MEDIUM	O	Wind speed control output
18	LOW	O	Wind speed control output
19	VDD	POWER	Positive power supply
20	BUZ	O	Trigger output to drive piezo
21	OSC2	O	Crystal output
22	OSC1	I	Crystal input
23	VSS	POWER	Negative power supply (Substrate)
24	LTO	O	Light control output



FUNCTION DESCRIPTION

SM3015 has two control types : panel keypad and infrared remote control.
There are four to eight control signal operations :

- * Start-up by SPEED key
 - a. function turn off (OFF key)
 - b. wind mode select (MODE key)
 - c. start-up function and wind speed select (SPEED key)
 - d. timer setting (TIMER key)
 - e. swing head or tuner for swing angle (SW1 and SW2 key)
 - f. lighting control (LIGHT key)

- * Start-up by ON/OFF key
 - a. function control (ON/OFF key)
 - b. wind mode select (MODE key)
 - c. wind speed select (SPEED key)
 - d. timer setting (TIMER key)
 - e. swing head or tuner for swing angle (SW1 and SW2 key)
 - f. lighting control (LIGHT key)

All functions can be planned by user like an MCU for more product application.

Only SPEED or ON/OFF key can enable the fan controller, except for the light control. Wind mode, timer and swing head inputs can not be accepted when fan is not activated. The fan controller will be turned off by timer and OFF (ON/OFF) key inputs.

When more than one key are pressed, controller will not accept the multi-key's control signal, if the panel keys are pressed more than six seconds, controller will generate a " BI-BI-BI-BI" warning sound. When fan is enabled by SPEED or ON/OFF key, the initial state of fan controller is as follows:

- * Memory function available
 - If Fan controller is OFF on sleep mode, all memory functions will be returned to the LAST TURN ON STATE.
 - a. Grade as last state but with starting medium wind for three seconds (MASK option)
 - b. The wind mode as last state except sleep mode
 - c. Swing function as last state
 - d. Timer setting off
 - e. Light is independent

- * Non-memory function (Bonding option)
 - a. Grade is low wind function but with starting medium wind for three seconds (MASK option)
 - b. Normal wind mode operation
 - c. Timer setting and swing head off
 - d. Light is independent

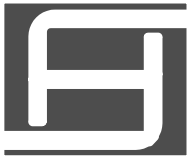

A. OFF KEY

When fan controller is on, press the OFF key on panel or remote control handset, fan functions will be turned off except light output.

* BONDING OPTION : **ON/OFF KEY**

When fan controller functions are on, press ON/OFF key on panel or remote control handset, fan functions will be turned off; if functions are off, press the key to turn on fan functions. Light output is independent.

B. SPEED KEY

When fan control is off, press SPEED key on panel or remote control handset, fan is turned on; when memory function is available, the wind grade will operate as last state. Both conditions have three seconds starting wind. Press the SPEED key again, the wind will be changed as follows :

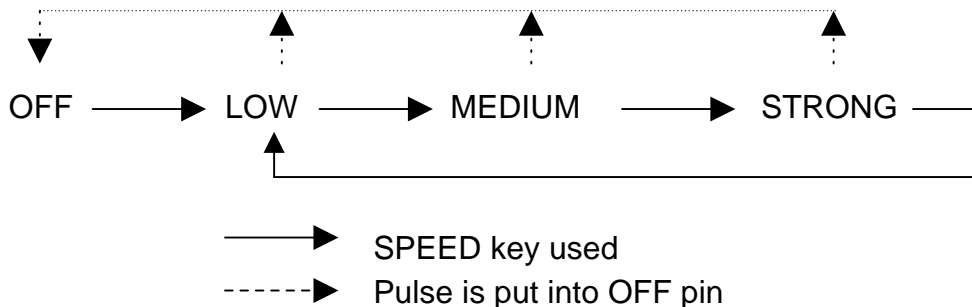

* BONDING OPTION: **SPEED KEY ONLY**

If fan controller is off, SPEED key cannot be used, must press ON/OFF key to turn on the fan controller. When fan controller is on, press SPEED key on panel or remote control handset and wind grade changes as follows:

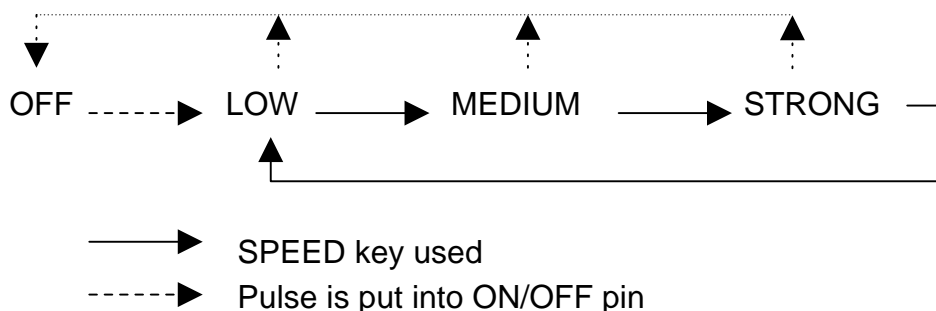

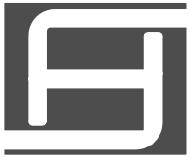

* MASK OPTION: WIND GRADE

a. There are two types of wind grade control function to choose. If fan controller is on, press SPEED key on panel or remote control handset, wind grade changes as follows:

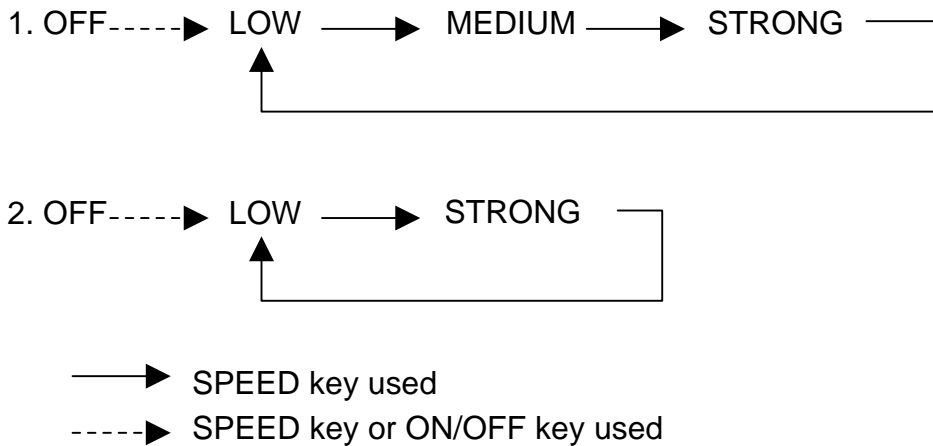

b. Memory or non-memory function can be chosen.

C. MODE KEY

SM3015 has four types of wind mode: normal, rhythm, sleep + rhythm, and sleep + normal these can be chosen by mode key setting. Memory function is available except on sleep mode.

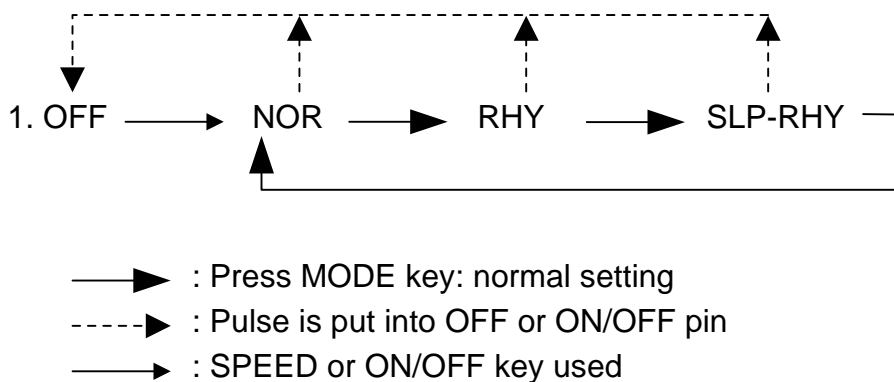



* MASK OPTION:

- a. Memory or non-memory function can be chosen.
- b. There are five kinds of wind mode operation.

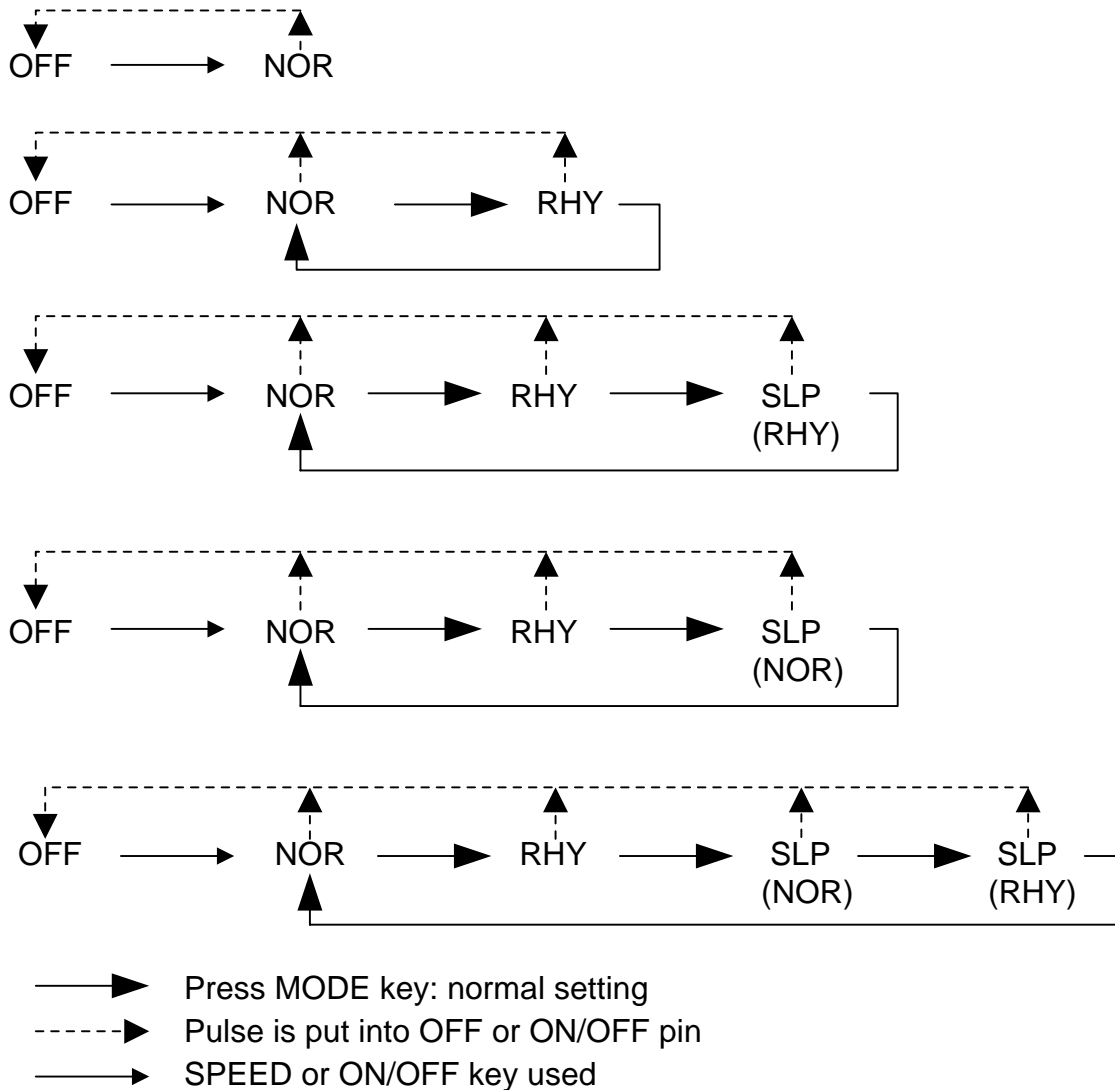

D. LIGHTING CONTROL KEY

The LIGHT key is independent and the output is toggle function. When the LIGHT key is pressed on panel or remote control handset, operation is as follows :

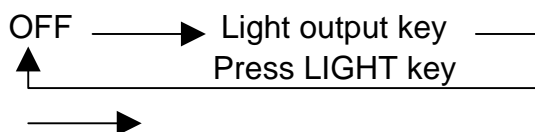

* MASK OPTION:

Fan controller is off, LIGHT key cannot be used.



E. TIMER KEY SETTING

SM3015 has many types of timer adder for three or four steps. Timer key will not activate when fan controller is off. These types of timer may be chosen by bonding option.

MODE A: Timer with accumulation

Timer Pulse No.	Four-steps Type				Three-steps Type		
	A*1	A*2	A*3	A*4	A*1	A*2	A*3
1	●				●		
2		●				●	
3	●	●			●	●	
4			●				●
5	●		●		●		●
6		●	●			●	●
7	●	●	●		●	●	●
8				●			
9	●			●			
10		●		●			
11	●	●		●			
12			●	●			
13	●		●	●			
14		●	●	●			
15	●	●	●	●			

MODE B: Timer with non-accumulation

Timer Pulse No.	Four-steps Type				Three-steps Type		
	A	B	C	D	A	B	C
1	●				●		
2		●				●	
3			●				●
4				●			

● LED display

* MASK OPTION:

A,B,C,D time base are common multiple by 15 minute ascending, and each number can be set by user.

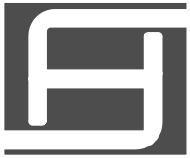

F. SWING KEY:SWING1 AND SWING2

The swing key will not activate when fan controller is off. Memory function is available, the swing output will operate as last state when press SPEED or ON/OFF key, except tuner function using.

A/C Type :

SM3015A has two keys of SW1 and SW2 to control the outputs of SHO1 and SHO2 (toggle function).

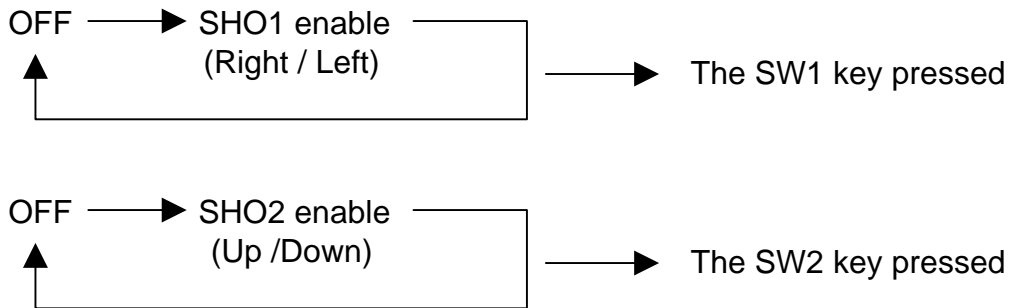

When SHO1 and SHO2 outputs enable together, the swing head has 3D function.

B/D Type :

SM3015B/D has only one SWING key to control the outputs of SHO1 and SHO2.

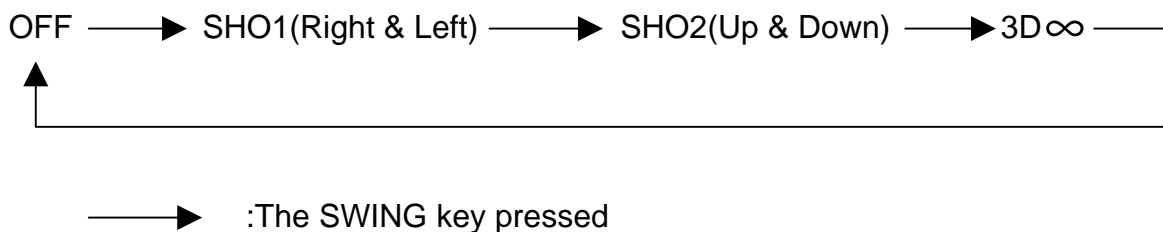

* MASK OPTION :

- SHO1 and SHO2 output can be enabled when fan controller is off.
- SHO1 and SHO2 output functions can be chosen as a continuous outputs respectively like a micro-swing switch to tune the swing angle.



G. SLT KEY

When fan controller functions are on, press the sleep mode, then press the SLT key to set the timer of the wind grade down. The time base of SLT key is 0.5HR/1HR/2HR.

H. MEMORY FUNCTION

Memory of speed, mode(except sleep mode) and swing functions can be set independently. Memory function can be cancelled by Bonding option. When memory function is available, wind speed mode and swing functions will operate as last state; if last state is sleep mode, press SPEED or ON/OFF key enable fan controller while memory functions(Speed/Mode/Swing) will be returned to the last state before sleep mode operation.

I. STARTING WIND

Memory or non-memory type, fan controller starts with three seconds starting wind.

J. CUSTOMER CODE

SM3015 provide two-bit customer code to distinguish different product models. There are four types, that can be set by diode.

- Set code bit to "0", connect diode to COM1/COM2 and SWING/SW1 terminal
- Set code bit to "1", open the circuit.

D1	D2
0	0
0	1
1	0
1	1

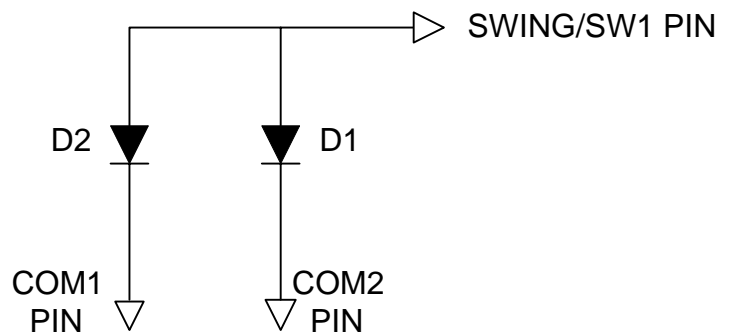



K. BUZZER

Any key pressed on panel or fan controller receives a control signal from remote control handset, will generate a 4KHz 50% duty cycle pulse train on buzzer output pin.

a. When FAN is from stop mode to start mode (press SPEED or ON_OFF key)

Buzzer output will generate a "BI-BI" sound.

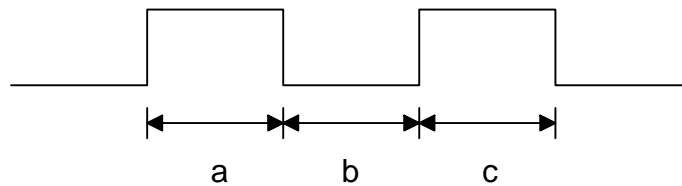

b. When FAN is from start mode to stop mode (press OFF/ON_OFF key)

Buzzer output will generate a long "BI" sound.

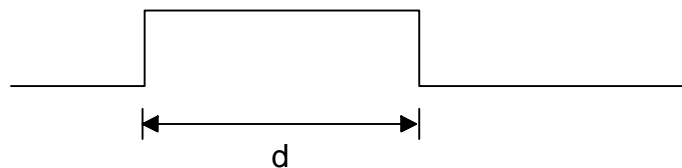

c. When FAN is operating (press any key other than OFF/ON_OFF key)

Buzzer output will generate a "BI" sound.

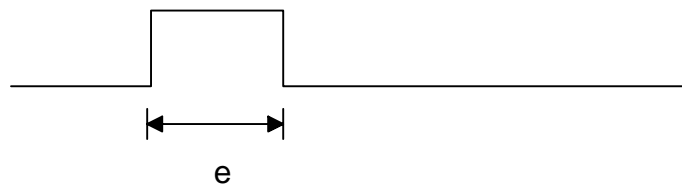

When $a = c = e = 62\text{ms}$
 $b = 124\text{ms}$
 $d = 250\text{ms}$

* MASK OPTION

Fan controller will generate a 150ms duration 2KHz 50% duty cycle pulse train on BUZ output pin.

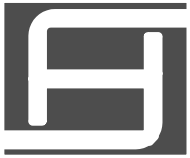

L-1. RHYTHM WIND FUNCTION (DEFAULT)

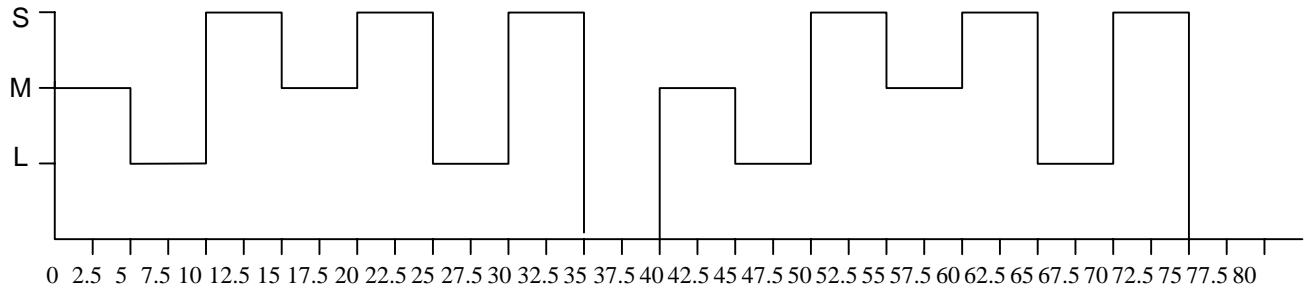

STRONG RHYTHM WIND PATTERN

(SEC)

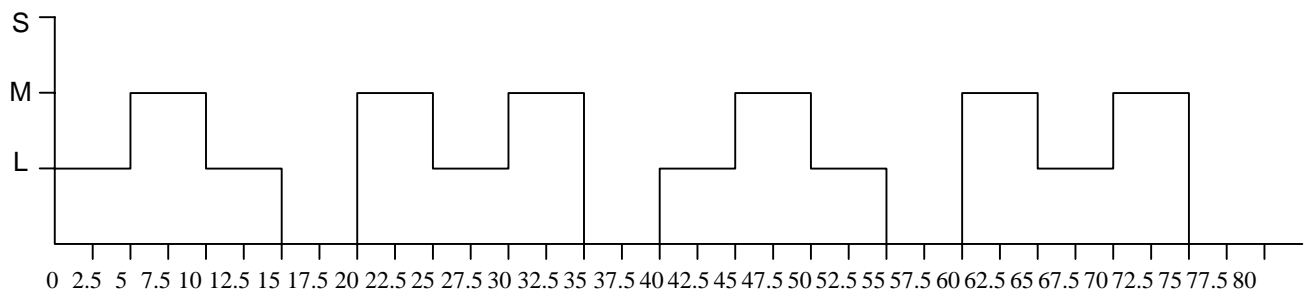

MEDIUM RHYTHM WIND PATTERN

(SEC)

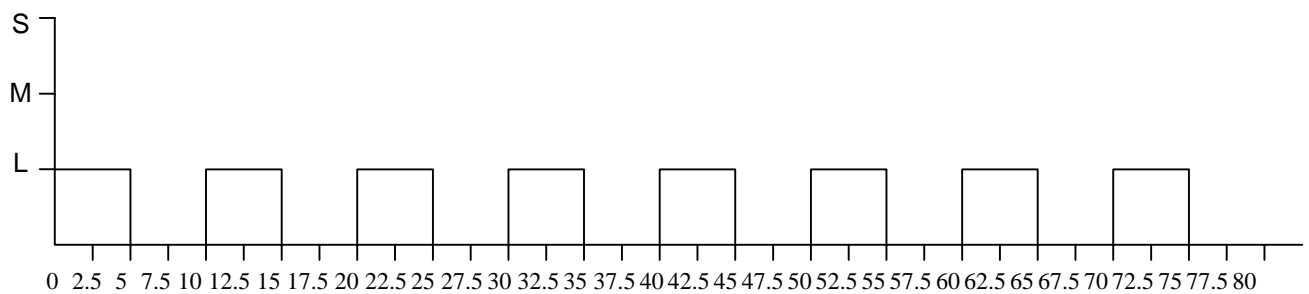

LOW RHYTHM WIND PATTERN

(SEC)

*MASK OPTION:

32 patterns per cycle, each pattern (2.5 seconds) can be set by user.



L-2. RHYTHM WIND FUNCTION (DEFAULT)

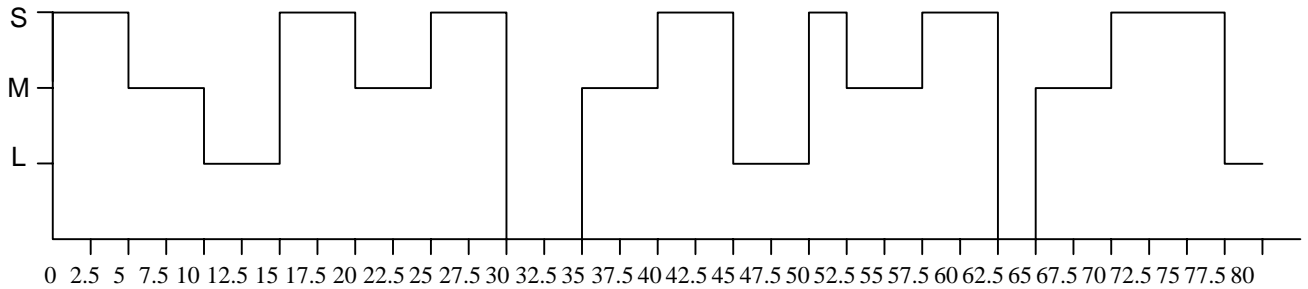

STRONG RHYTHM WIND PATTERN

(SEC)

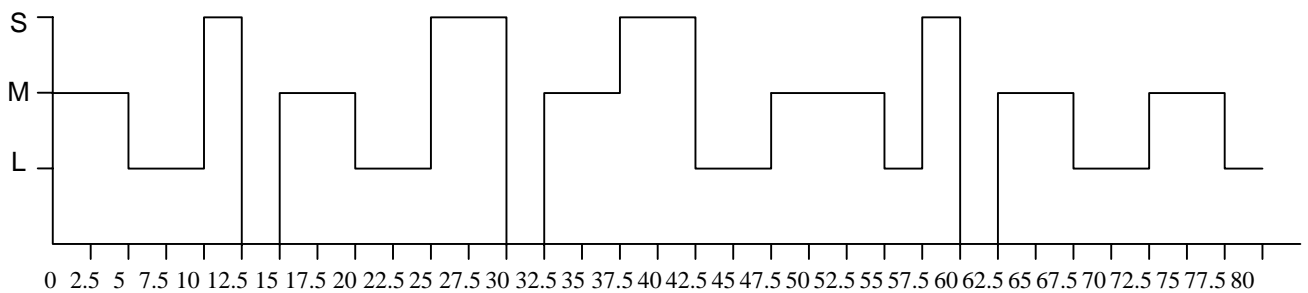

MEDIUM RHYTHM WIND PATTERN

(SEC)

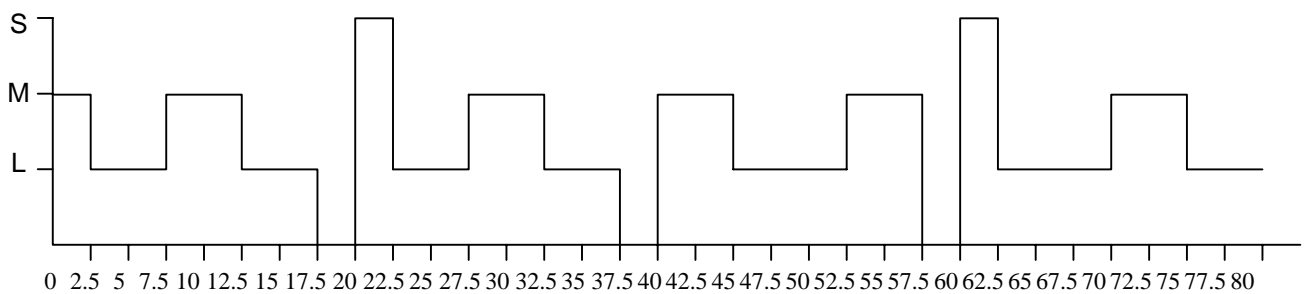

LOW RHYTHM WIND PATTERN

(SEC)

*MASK OPTION:

32 patterns per cycle, each pattern (2.5 seconds) can be set by user.



M. SLEEP FUNCTION

In sleep mode, wind grade is changed by timing automatically.

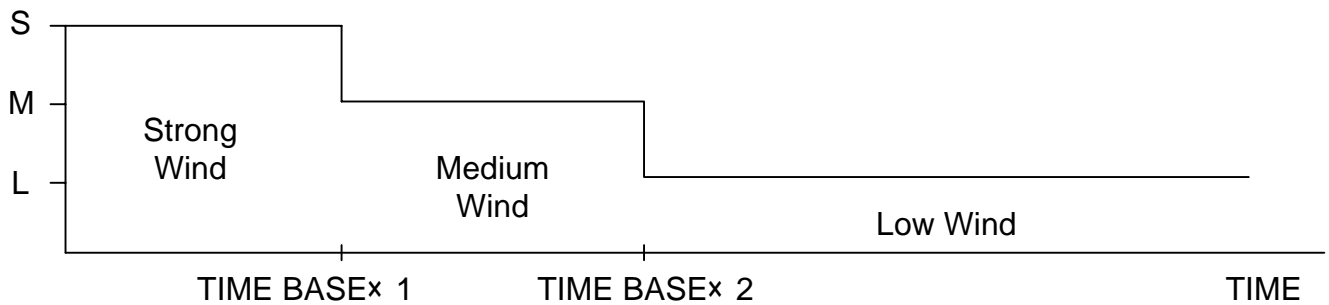

TIMER OPTION:

Sleep Hold Time Key can be chosen the time base of 0.5/1/2HR by SLT key in SM3015C/D type only.



**TIMING
CONTROL**

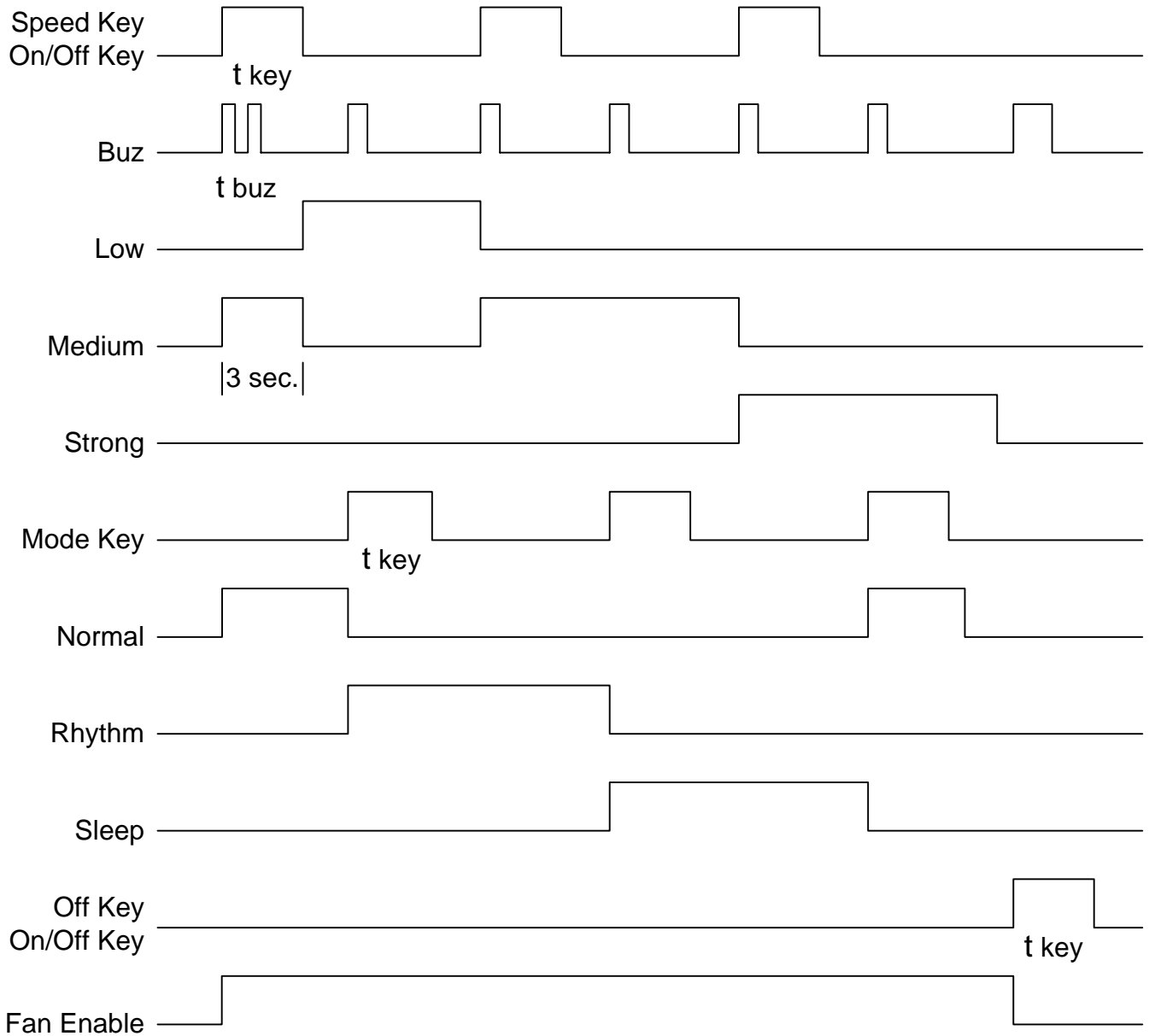

* NOTE: t_{buz} see page 12 and t_{key} see page 6

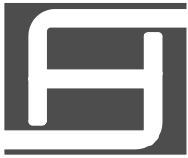

DC ELECTRICAL CHARACTERISTICS

Parameter	Symbol	Test Conditions	Limits			Unit
			Min.	Typ.	Max.	
Supply Voltage	VDD		3	5	6	V
Stand-by Current	ISB	OSC stop all output pins open all input fixed to VDD			500	uA
Input High Level	VIH		3.5			V
Input Low Level	VIL				1.5	V
Sink Current (OFF,MODE,SPEED TIMER,SLEEP)	IOL	VOL=+0.7V		10		mA
Source Current (OFF,MODE,SPEED TIMER,SLEEP)	IOH	VOH=+4.3V		10		mA
Triac Sink Current (S,M,L,SW1, SW2,LIGHT)	IOL	VOL=+0.7V		10		mA
Triac Source Current (S,M,L,SW1, SW2,LIGHT)	IOH	VOH=+4.3V		5		mA
Sink Current (COM1~COM3)	IOL	VOL=+0.7V		40		mA
Source Current (COM1~COM3)	IOH	VOH=+4.3V		10		mA
Sink Current (BUZ)	IOL	VOL=+0.7V		4		mA
Source Current (BUZ)	IOH	VOH=+4.3V		5		mA
Pull-high Resister (Input pin)	RPH			200		K OHM

*NOTE: All test conditions are on VDD = 5V / VSS = GND

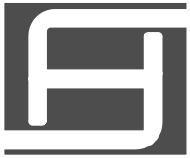

ABSOLUTE MAXIMUM RATINGS

Parameter	Symbol	Test conditions	Ratings	Unit
Supply Voltage	VDD-VSS		-0.3~6	V
Input Voltage	Vi-VSS		VSS-0.3~VDD+0.3	V
Output Voltage	Vo-VSS		VSS-0.3~VDD+0.3	V
Maximum Power Consumption	Pa	VDD-VSS=5V	500	mW
Operating Temperature	Topr		-10~70	°C
Storage Temperature	Tstg		-40~125	°C

AC CHARACTERISTICS

Oscillator Frequency:455KHz/32.768KHz

Parameter	Symbol	Ratings			Unit
		Min.	Typ.	Max.	
Key Press Duration	t key		30		ms
Remote Input Bit Duration	t bit	1.17	1.68	2.18	ms



SM5021 (ENCODER) APPLICATION CIRCUIT

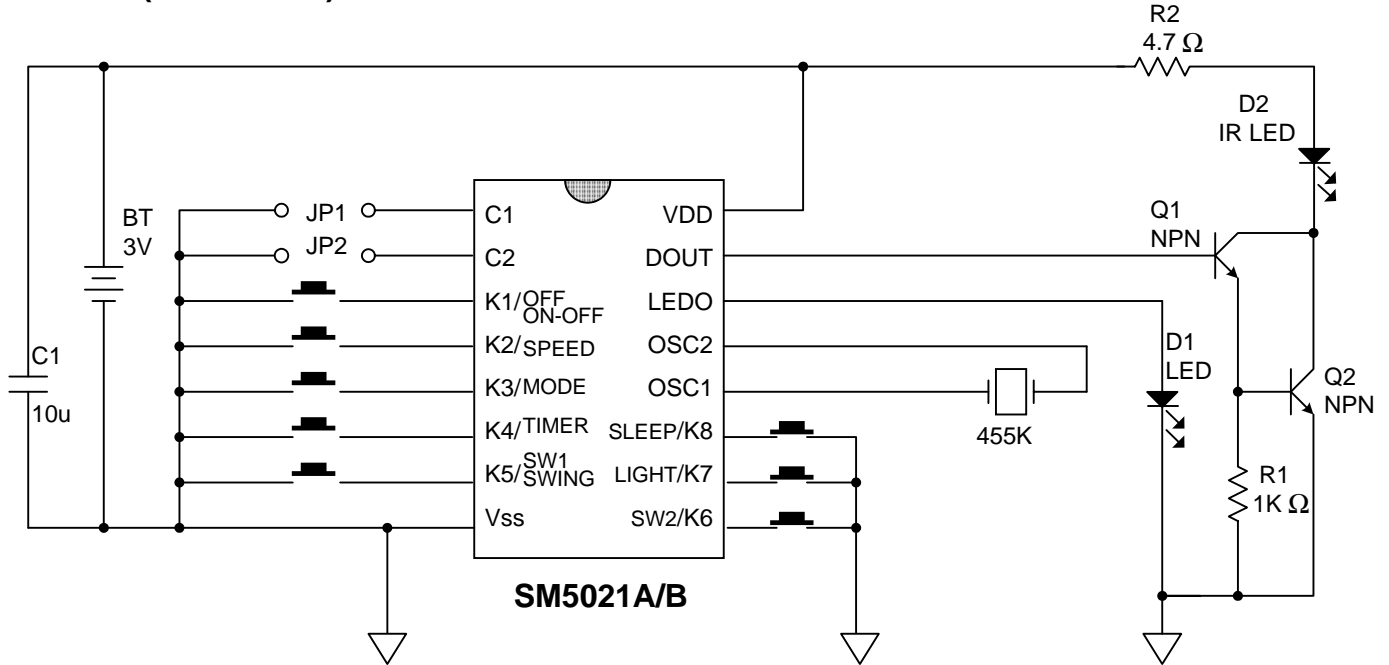

SM3015 POWER SUPPLY APPLICATION CIRCUIT

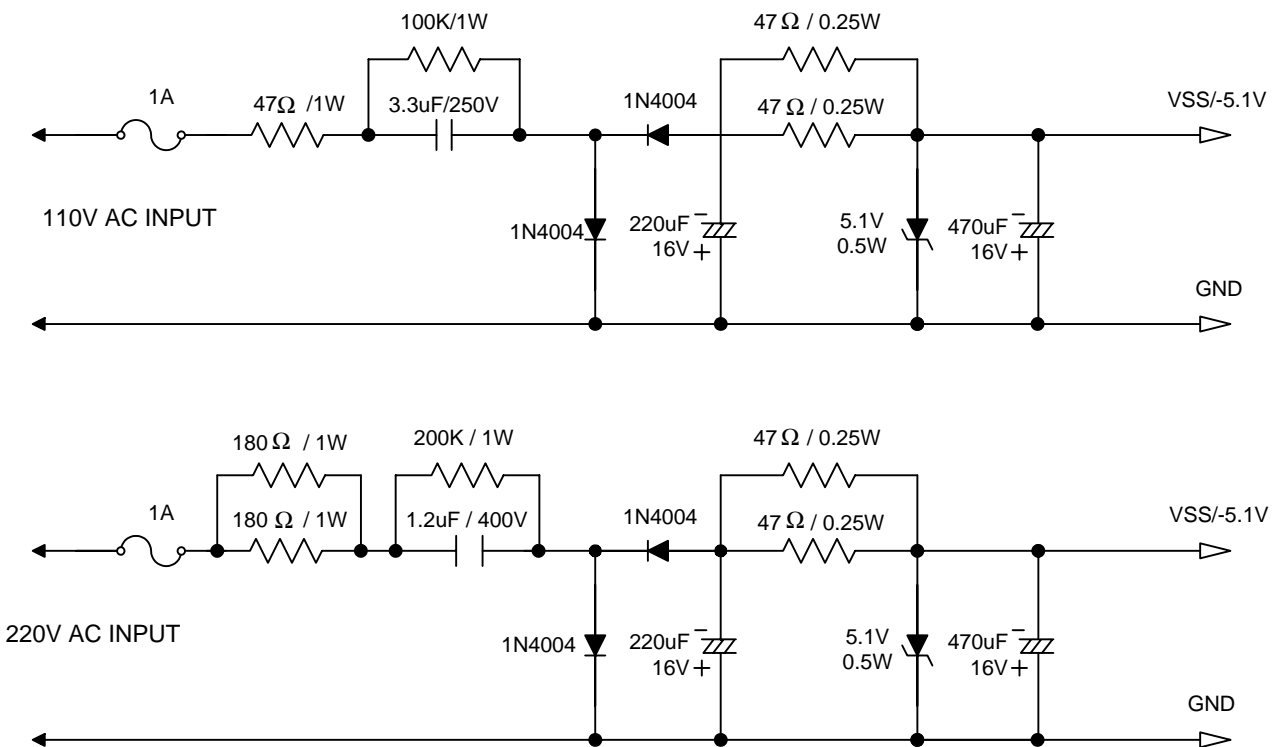



三合微科技股份有限公司

SAMHOP Microelectronics Corp.

SM3015

REMOTE FAN MCU

SM3015 APPLICATION CIRCUIT

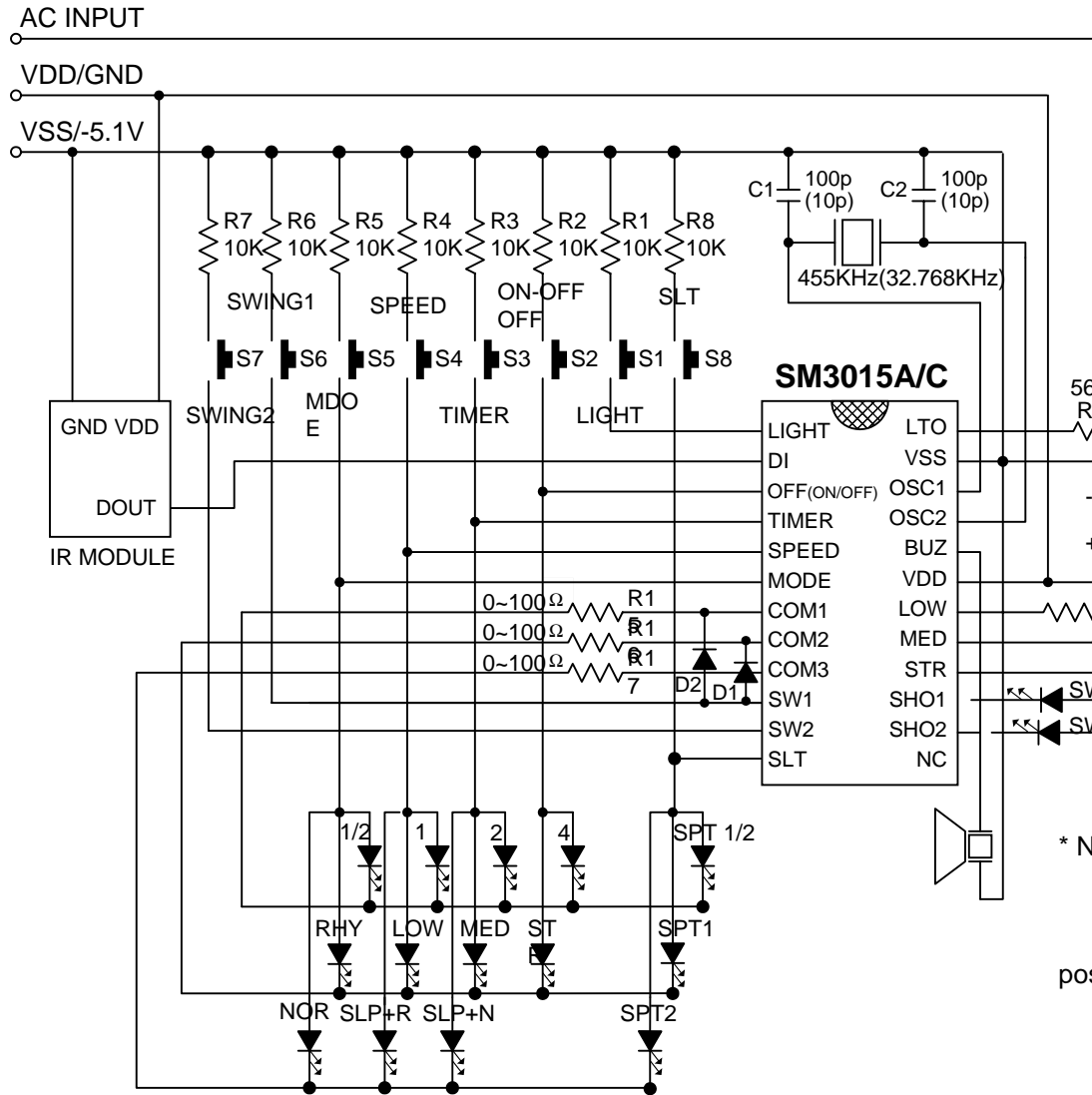

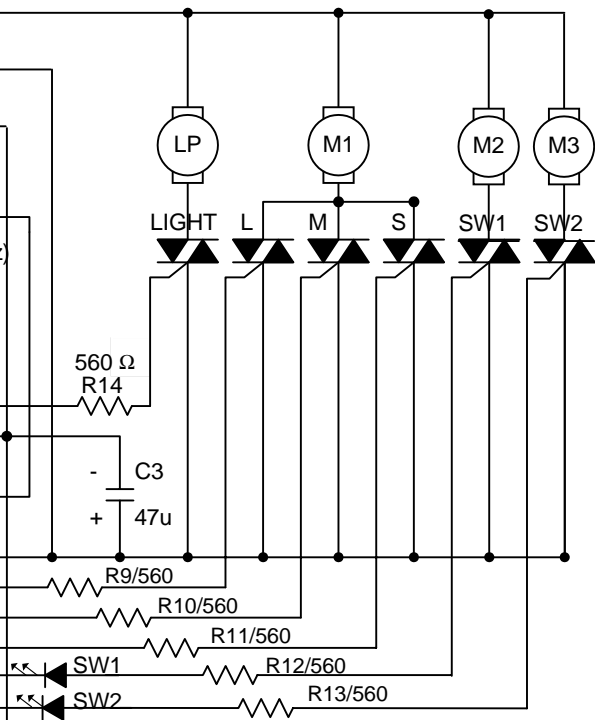

- * NOTE: 1. D1 and D2 for custom code.
 Code 1: open the diode
 Code 0: use the diode
2. C3 must be closed to IC as possible of PCB layout.
3. A Type: SLT PIN = NC
4. Oscillator Option:

Option	Oscillator	C1,C2
1	455KHz	100p
2	32.768KHz	10p

V.2.0 Mar 8, 2002



SM3015 APPLICATION CIRCUIT

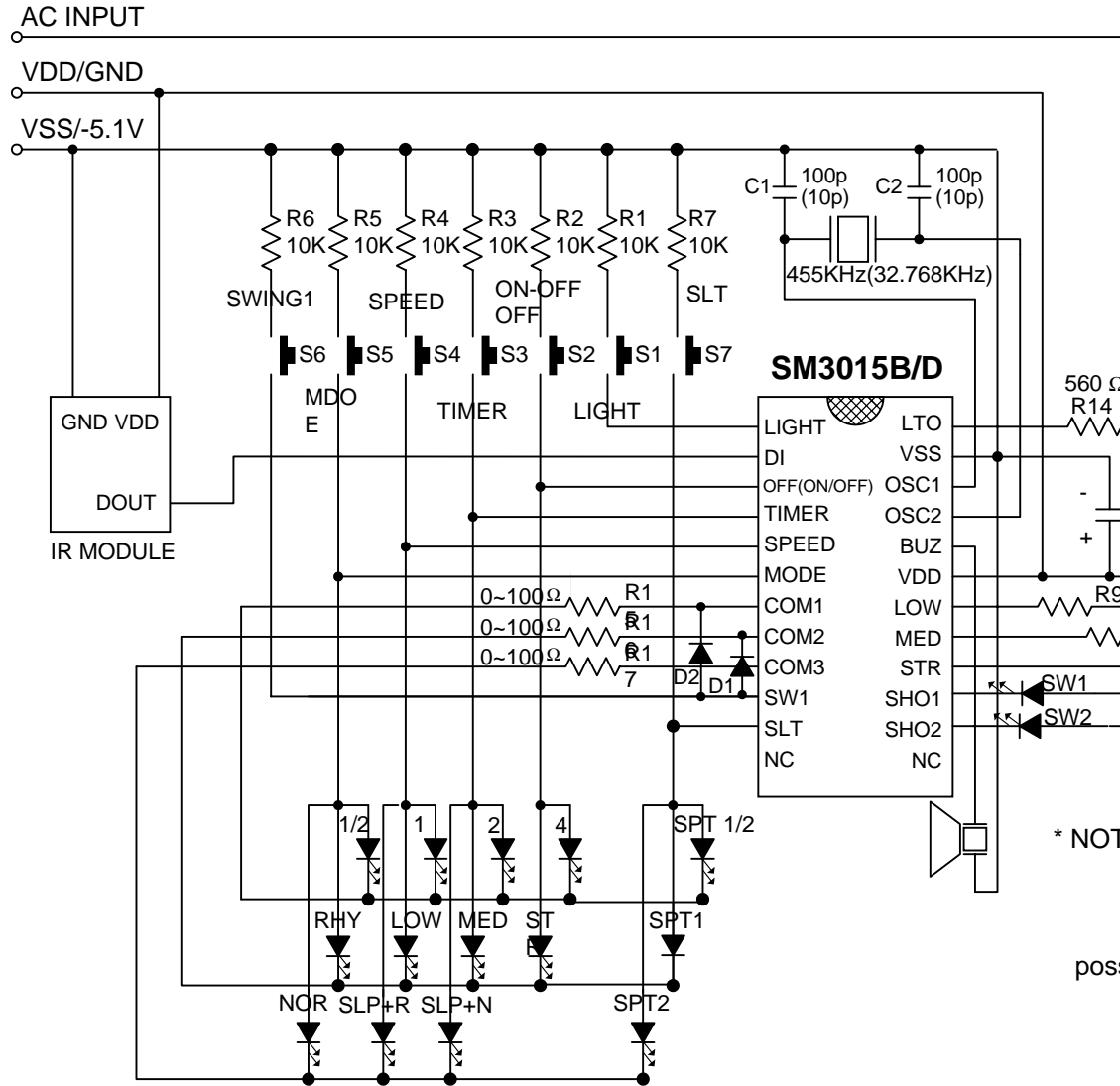

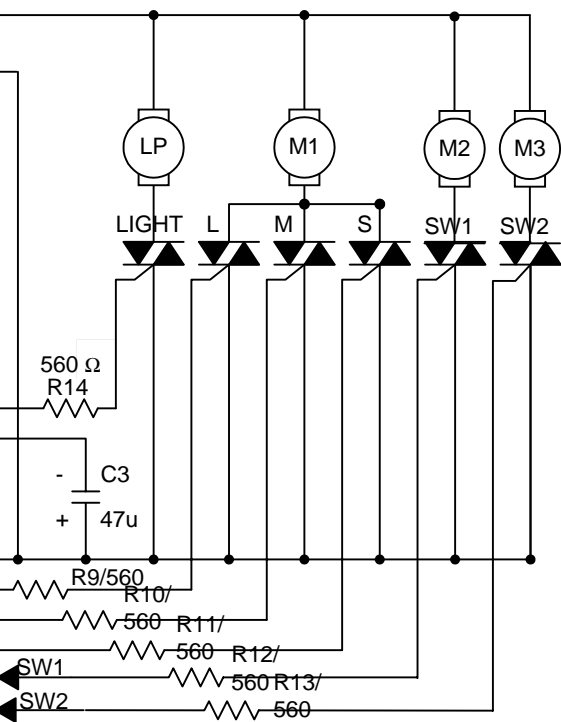

* NOTE: 1. D1 and D2 for custom code.

Code 1: open the diode

Code 0: use the diode

2. C3 must be closed to IC as possible of PCB layout.

3. B Type: SLT PIN = NC

4. Oscillator Option:

Option	Oscillator	C1,C2
1	455KHz	100p
2	32.768KHz	10p

V.2.0 Mar 8, 2002



ORDERING INFORMATION

