

SANYO	No. 4936	STK73908
	Self-Excitation Type Feedback Control (World Spec.) Switching Regulator (210W Output)	

Overview

The STK73908 incorporates on-chip all the power switching, amplifier, overcurrent protection and driver circuits required in a self-excitation type feedback control off-line switching regulator. As a result, it can be used in the design of switching power supplies with minimal number of external components. Furthermore, the adoption of MOSFET power switching elements supports a higher oscillator frequency than that possible with bipolar transistors. This allows smaller pulse transformers and capacitors to be used, making it possible to construct miniature power supply systems.

Applications

- CRT/CTV power supplies
- Office automation equipment power supplies

Features

- Power MOSFET devices
- Feedback control for high output voltage precision
- Driver circuit on-chip
- Overcurrent protection circuit on-chip
- Pin compatible with all other devices in the same series of devices with 110 to 280W power ratings
- Higher oscillator frequency allows the use of smaller pulse transformers
- IMST substrate acts as an electromagnetic shield, making low-noise designs possible

Package Dimensions

unit: mm

4121

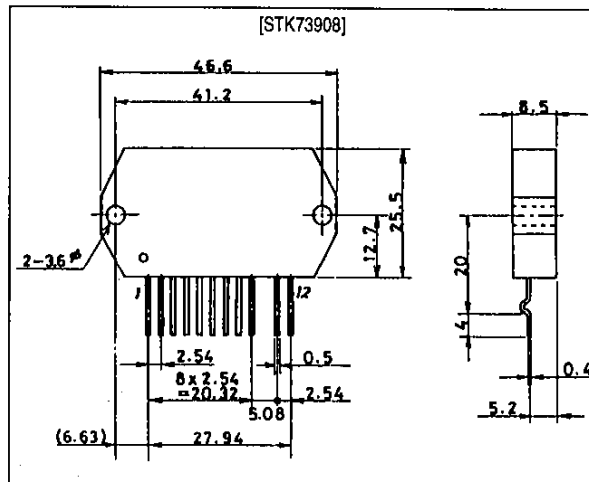

■ No products described or contained herein are intended for use in surgical implants, life-support systems, aerospace equipment, nuclear power control systems, vehicles, disaster/crime-prevention equipment and the like, the failure of which may directly or indirectly cause injury, death or property loss.

■ Anyone purchasing any products described or contained herein for an above-mentioned use shall:

- ① Accept full responsibility and indemnify and defend SANYO ELECTRIC CO., LTD., its affiliates, subsidiaries and distributors and all their officers and employees, jointly and severally, against any and all claims and litigation and all damages, cost and expenses associated with such use;
- ② Not impose any responsibility for any fault or negligence which may be cited in any such claim or litigation on SANYO ELECTRIC CO., LTD., its affiliates, subsidiaries and distributors or any of their officers and employees jointly or severally.

■ Information (including circuit diagrams and circuit parameters) herein is for example only; it is not guaranteed for volume production. SANYO believes information herein is accurate and reliable, but no guarantees are made or implied regarding its use or any infringements of intellectual property rights or other rights of third parties.

SANYO Electric Co., Ltd. Semiconductor Business Headquarters
TOKYO OFFICE Tokyo Bldg., 1-10, 1 Chome, Ueno, Taito-ku, TOKYO, 110 JAPAN

Block Diagram

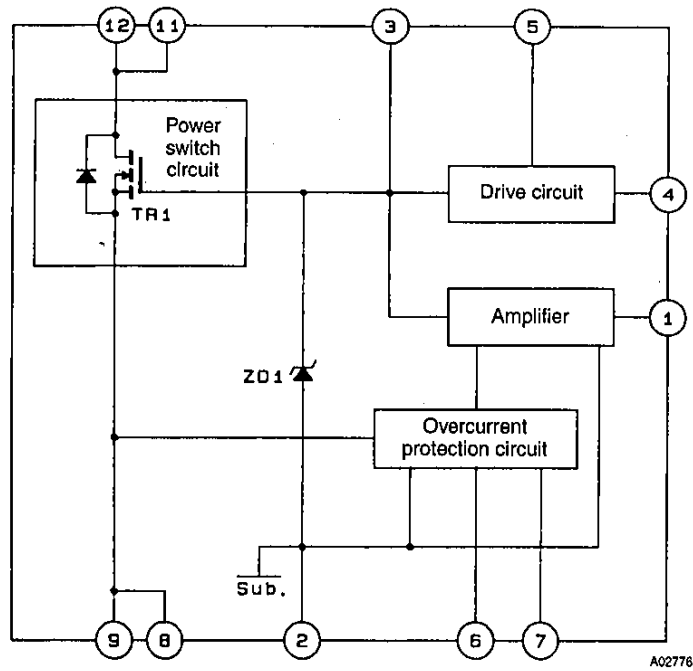

The back surface of the IC is not an insulator, and is effectively at pin 2 potential.

Pin Functions

Number	Function
1	Amplifier circuit control
2	Ground
3	TR1 gate
4	Drive voltage input
5	Starting voltage input
6	OCP setting level input
7	OCP input-voltage dependency detection input
8	TR1 source
9	
11	TR1 drain
12	

Specifications

Maximum Ratings at $T_a = 25^\circ\text{C}$, $T_c = 25^\circ\text{C}$ unless otherwise specified

Parameter	Symbol	Conditions	Ratings	Unit
Operating substrate temperature	$T_c \text{ max}$	Recommended value is 105°C .	115	$^\circ\text{C}$
AC input voltage	V_{AC}	Specified test circuit	280	V _{rms}
Operating temperature	T_{opg}		-10 to +85	$^\circ\text{C}$
Storage temperature	T_{stg}		-30 to +115	$^\circ\text{C}$
Maximum output power	$W_o \text{ max}$	Specified test circuit, $V_o = 115\text{V}$	210	W

STK73908

Parameter	Symbol	Conditions	Ratings	Unit
[TR1]				
Drain current	I_D	Refer to ASO characteristics for overcurrent condition.	6	A
Pulse drain current	$I_{D(pulse)}$		15	A
Drain reverse current	I_{DR}		6	A
Gate-source voltage	V_{GS}		± 30	V
Allowable power dissipation	P_D		100	W
Chip junction temperature	T_j max		150	$^{\circ}C$
[ZD1]				
Allowable power dissipation	P_{ZD1}		500	mW
Chip junction temperature	$T_j(ZD1)$ max		125	$^{\circ}C$

Allowable Operating Ranges at $T_a = 25^{\circ}C$

Parameter	Symbol	Conditions	Ratings	Unit
Pin 4 input voltage	V_4		± 8 to ± 24	V
Oscillator frequency	f_{osc}		20 to 100	kHz

Operating Characteristics at $T_a = 25^{\circ}C$, $T_c = 25^{\circ}C$ unless otherwise specified, specified test circuit

Parameter	Symbol	Conditions	min	typ	max	Unit
[TR1]						
Drain-source breakdown voltage	$V_{(BR)DSS}$	$I_D = 10mA, V_{GS} = 0V$	900	-	-	V
Gate-source cutoff voltage	$V_{GS(off)}$	$I_D = 1mA, V_{DS} = 10V$	2.0	-	3.0	V
ON resistance	$R_{DS(on)}$	$I_D = 3A, V_{GS} = 10V$	-	2.0	3.0	Ω
Input capacitance	C_{iss}	$V_{DS} = 10V, V_{GS} = 0V, f = 1MHz$	-	1200	-	pF
[ZD1]						
Zener voltage	V_Z	$I_Z = 5mA$	23.7	-	26.3	V

Circuit Function Diagram

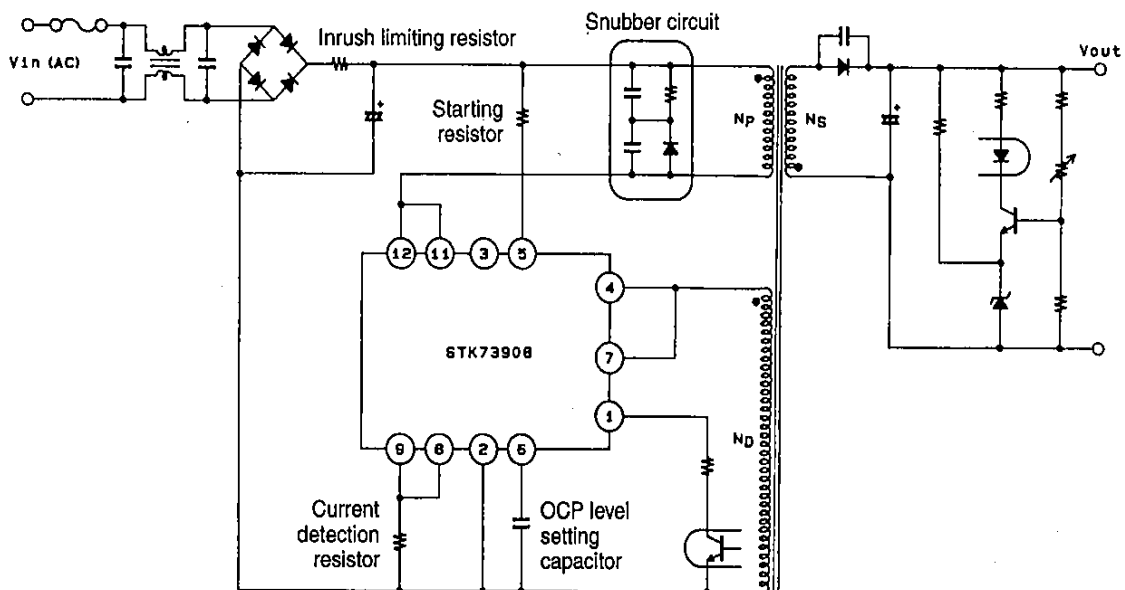

A02782

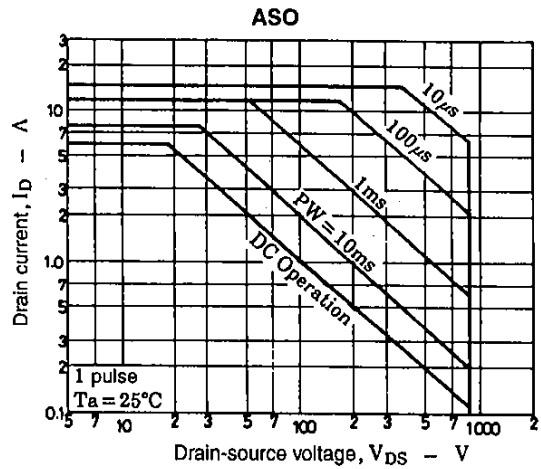
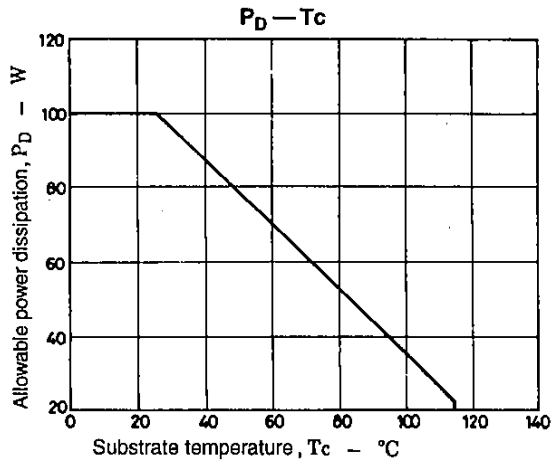

Sample Application Circuit (200V System)

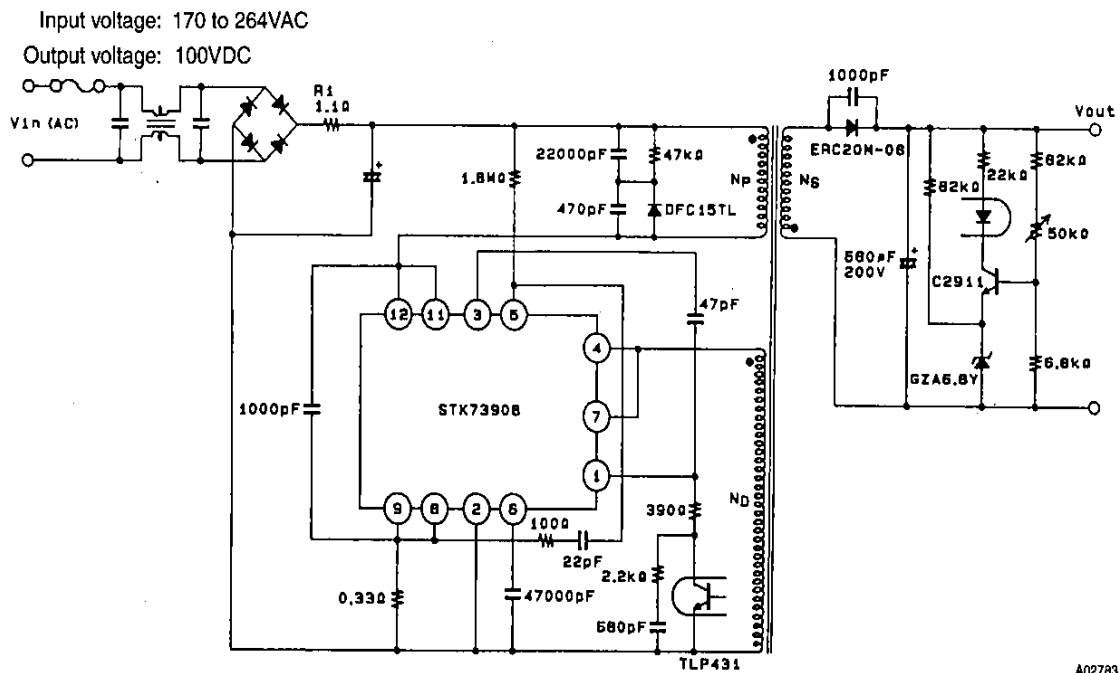

A02783

Pulse Transformer Specifications

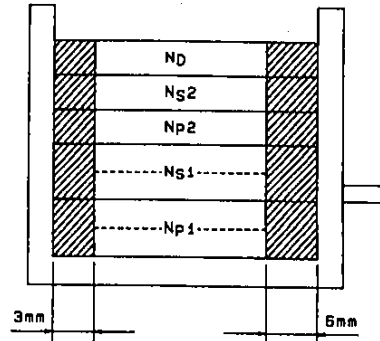
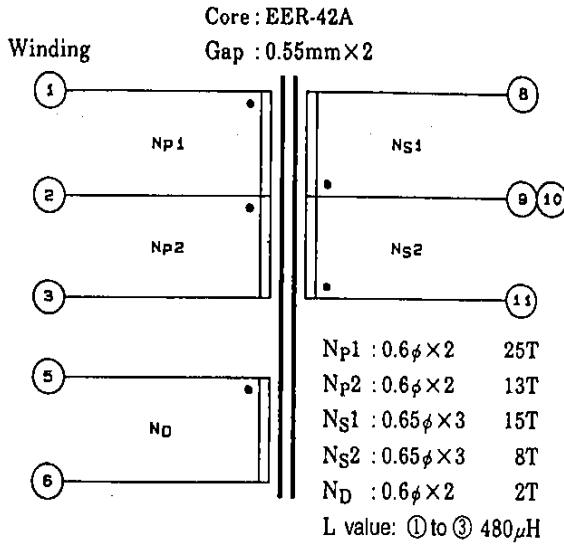

A02784

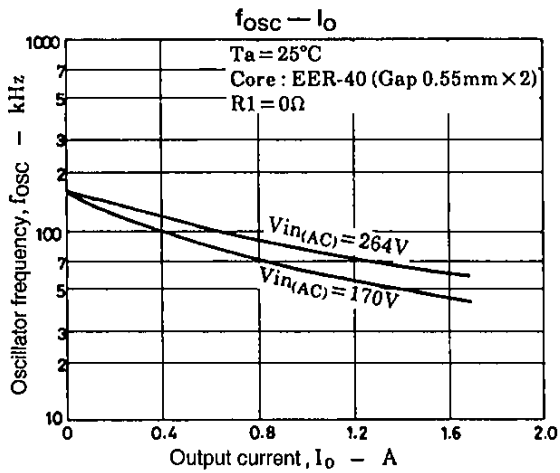
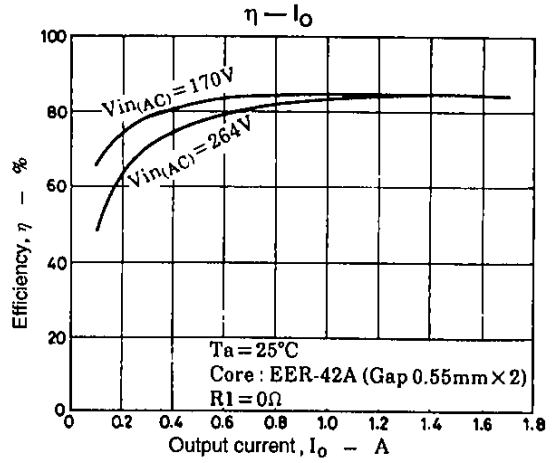
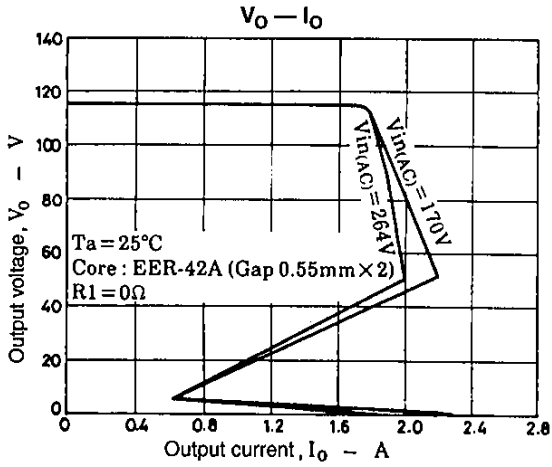

Sample Application Circuit (World Input System)

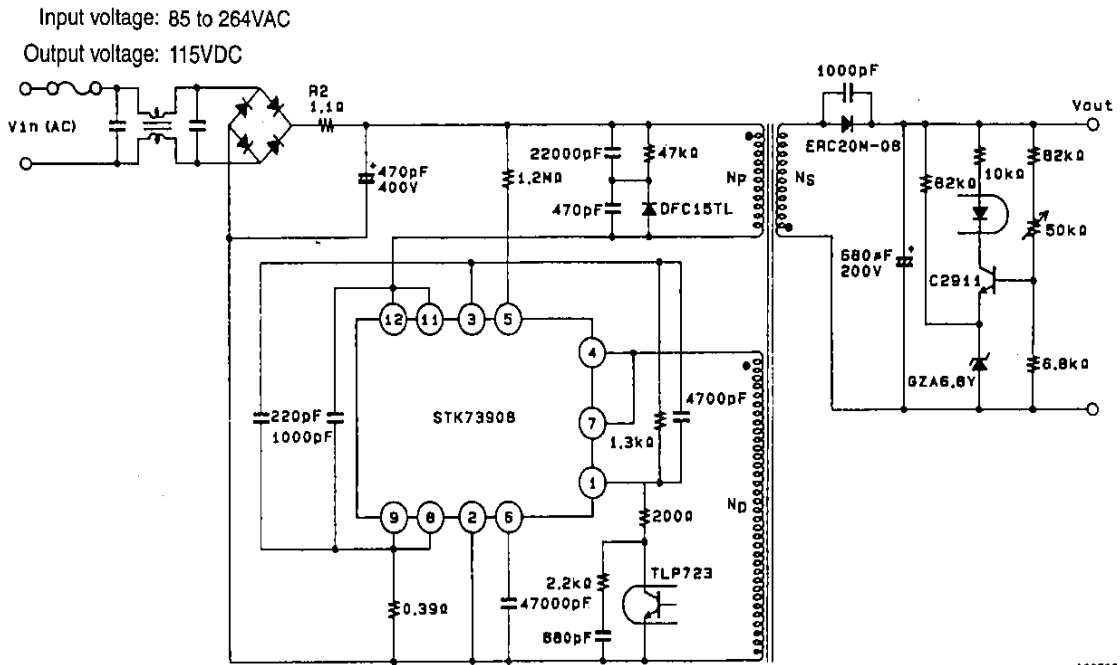

A02785

Pulse Transformer Specifications

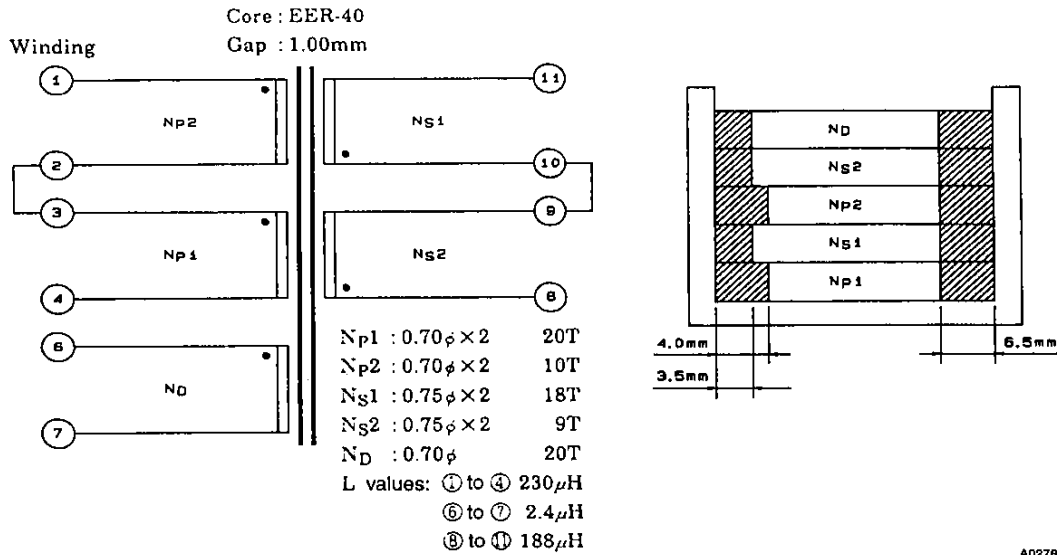

A02786

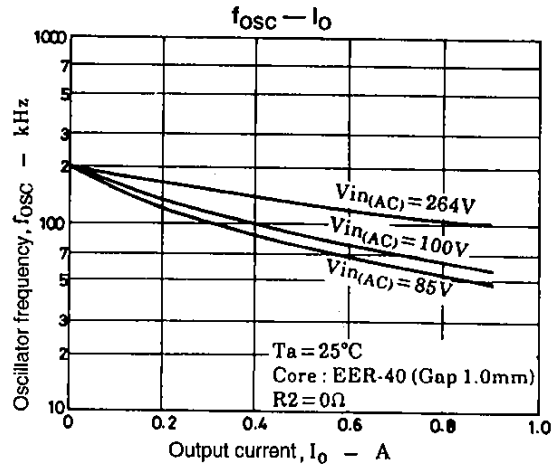
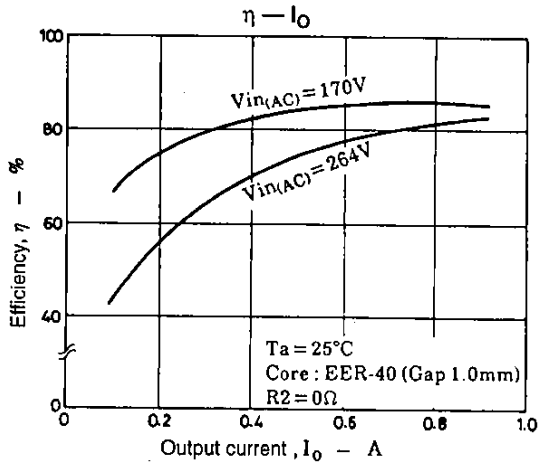
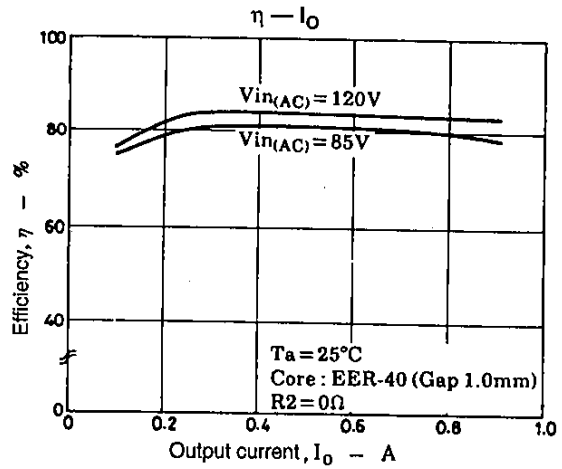
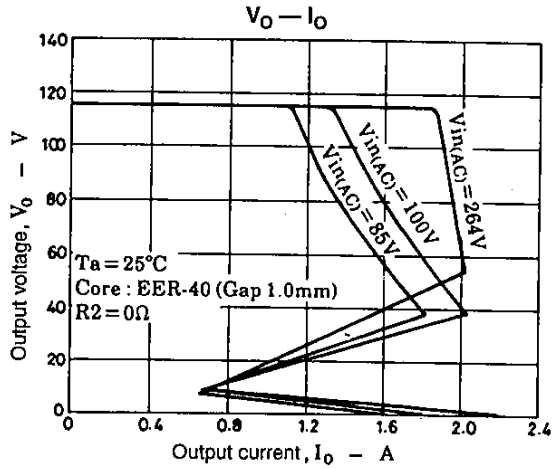

Series Organization

These devices form a series with varying output power ratings.

Device	Maximum ratings					Operating characteristics		
	V _{DSS} [V]	T _{stg} [°C]	T _c max [°C]	T _j max [°C]	I _D [A]	Input voltage [V]	Output power [W]	ON resistance [Ω]
STK73902	500	-30 to +115	+115	+150	6.0	85 to 132	110	1.4
STK73903					10.0		180	0.6
STK73904					12.0		210	0.55
STK73905					15.0		280	0.3
STK73906	900	-30 to +115	+115	+150	3.0	170 to 264	110	5.0
STK73907					5.0		180	3.0
STK73908					6.0		210	2.0
STK73909					8.0		280	1.2