



SANYO Semiconductors

DATA SHEET

STK433-060-E — Thick-Film Hybrid IC 2-channel class AB audio power IC, 50W+50W

Overview

The STK433-060-E is a hybrid IC designed to be used in 50W × 2ch class AB audio power amplifiers.

Applications

- Audio power amplifiers.

Features

- Pin-to-pin compatible outputs ranging from 30W to 60W.
- Can be used to replace the STK433-100 series (80W to 150W/2ch) and STK433-200/-300 series (3-channel) due to its pin compatibility
- Miniature package (47.0mm × 25.6mm × 9.0mm)
- Output load impedance: $R_L = 6\Omega$ to 4Ω supported
- Allowable load shorted time: 0.3 second
- Allows the use of predesigned applications for standby and mute circuits.

Series Models

	STK433-030-E	STK433-040-E	STK433-060-E	STK433-070-E
Output 1 (10%/1kHz)	30W×2 channels	40W×2 channels	50W×2 channels	60W×2 channels
Output 2 (0.4%/20Hz to 20kHz)	20W×2 channels	25W×2 channels	35W×2 channels	40W×2 channels
Max. rated V_{CC} (quiescent)	±34V	±38V	±46V	±50V
Max. rated V_{CC} (6 Ω)	±32V	±36V	±40V	±44V
Max. rated V_{CC} (4 Ω)	±26V	±30V	±33V	±37V
Recommended operating V_{CC} (6 Ω)	±21V	±24V	±27V	±29V
Dimensions (excluding pin height)	47.0mm×25.6mm×9.0mm			

- Any and all SANYO Semiconductor Co.,Ltd. products described or contained herein are, with regard to "standard application", intended for the use as general electronics equipment (home appliances, AV equipment, communication device, office equipment, industrial equipment etc.). The products mentioned herein shall not be intended for use for any "special application" (medical equipment whose purpose is to sustain life, aerospace instrument, nuclear control device, burning appliances, transportation machine, traffic signal system, safety equipment etc.) that shall require extremely high level of reliability and can directly threaten human lives in case of failure or malfunction of the product or may cause harm to human bodies, nor shall they grant any guarantee thereof. If you should intend to use our products for applications outside the standard applications of our customer who is considering such use and/or outside the scope of our intended standard applications, please consult with us prior to the intended use. If there is no consultation or inquiry before the intended use, our customer shall be solely responsible for the use.
- Specifications of any and all SANYO Semiconductor Co.,Ltd. products described or contained herein stipulate the performance, characteristics, and functions of the described products in the independent state, and are not guarantees of the performance, characteristics, and functions of the described products as mounted in the customer's products or equipment. To verify symptoms and states that cannot be evaluated in an independent device, the customer should always evaluate and test devices mounted in the customer's products or equipment.

SANYO Semiconductor Co., Ltd.

www.semiconductor-sanyo.com/network

Specifications

Absolute Maximum Ratings at Ta = 25°C (excluding rated temperature items), Tc=25°C unless otherwise specified

Parameter	Symbol	Conditions	Ratings	Unit
Maximum quiescent supply voltage 0	V _{CC} max (0)	When no signal	±46	V
Maximum supply voltage 1	V _{CC} max (1)	R _L ≥6Ω	±40	V
Maximum supply voltage 2	V _{CC} max (2)	R _L =4Ω	±33	V
Minimum operating supply voltage	V _{CC} min		±10	V
Pin 13 input voltage	VST max		-0.3 to +5.5	V
Thermal resistance	θj-c	Per power transistor	3.5	°C/W
Junction temperature	Tj max	Both the Tj max and Tc max conditions must be met.	150	°C
IC substrate operating temperature	Tc max		125	°C
Storage temperature	Tstg		-30 to +125	°C
Allowable load shorted time	*4 ts	V _{CC} =±27V, R _L =6Ω, f=50Hz, P _O =35W, 1-channel active	0.3	s

Operating Characteristics at Tc=25°C, R_L=6Ω, R_g=600Ω, VG=30dB, non-inductive load R_L, unless otherwise specified

Parameter	Symbol	Conditions *2					Ratings			unit
		V _{CC} (V)	f (Hz)	P _O (W)	THD (%)		min	typ	max	
Output power *1	P _O (1)	±27	20 to 20k		0.4		33	35		W
	P _O (2)	±27	1k		10			50		
	P _O (3)	±22	1k		1	R _L =4Ω		35		
Total harmonic distortion *1	THD (1)	±27	20 to 20k	5.0					0.4	%
	THD (2)	±27	1k					0.02		
Frequency characteristics *1	f _L , f _H	±27		1.0		+0 -3dB	20 to 50k			Hz
Input impedance	r _i	±27	1k	1.0				55		kΩ
Output noise voltage *3	V _{NO}	±33				R _g =2.2kΩ			1.0	mVrms
Quiescent current	I _{CCO}	±33				No loading	20	45	70	mA
Standby current	I _{CST}	±33							1	mA
Output neutral voltage	V _N	±33					-70	0	+70	mV
Pin 13 voltage when standby ON	VST ON	±27				Standby			0.6	V
Pin 13 voltage when standby OFF	VST OFF	±27				Operating	2.5			V

[Remarks]

- *1: For 1-channel operation
- *2: Unless otherwise specified, use a constant-voltage power supply to supply power when inspections are carried out.
- *3: The output noise voltage values shown are peak values read with a VTVM. However, an AC stabilized (50Hz) power supply should be used to minimize the influence of AC primary side flicker noise on the reading.
- *4: Use the transformer power supply circuit shown in the figure below for allowable load shorted time measurement.
- *5: Please connect -preV_{CC} Pin (#1 pin) with the stable minimum voltage and connect so that current does not flow in by reverse bias.
- * Thermal design must be implemented based on the conditions under which the customer's end products are expected to operate on the market.
- * A thermoplastic adhesive is used to adhere the case.

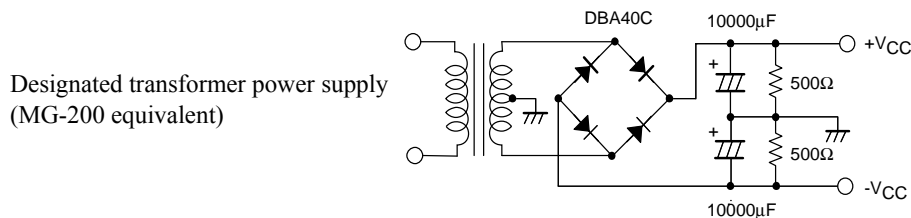

Package Dimensions

unit:mm (typ)

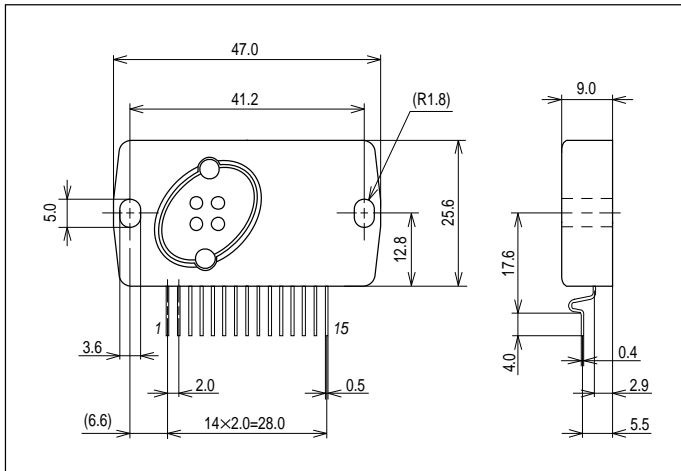

Internal Equivalent Circuit

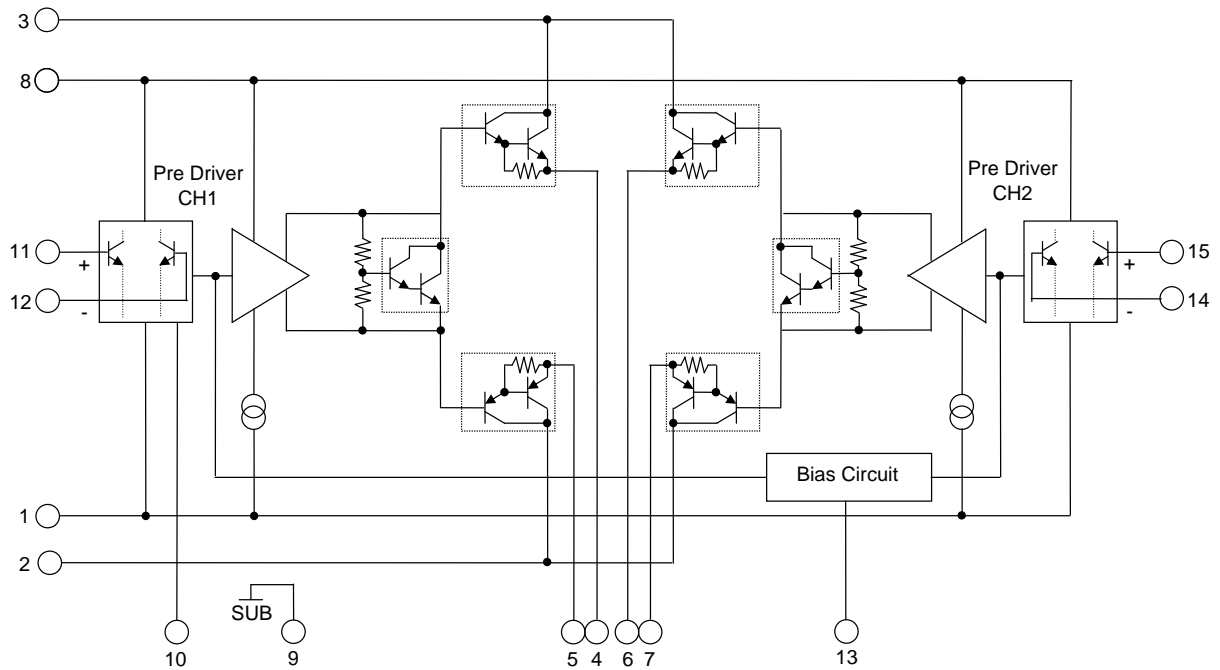

STK433-060-E

Application Circuit Example

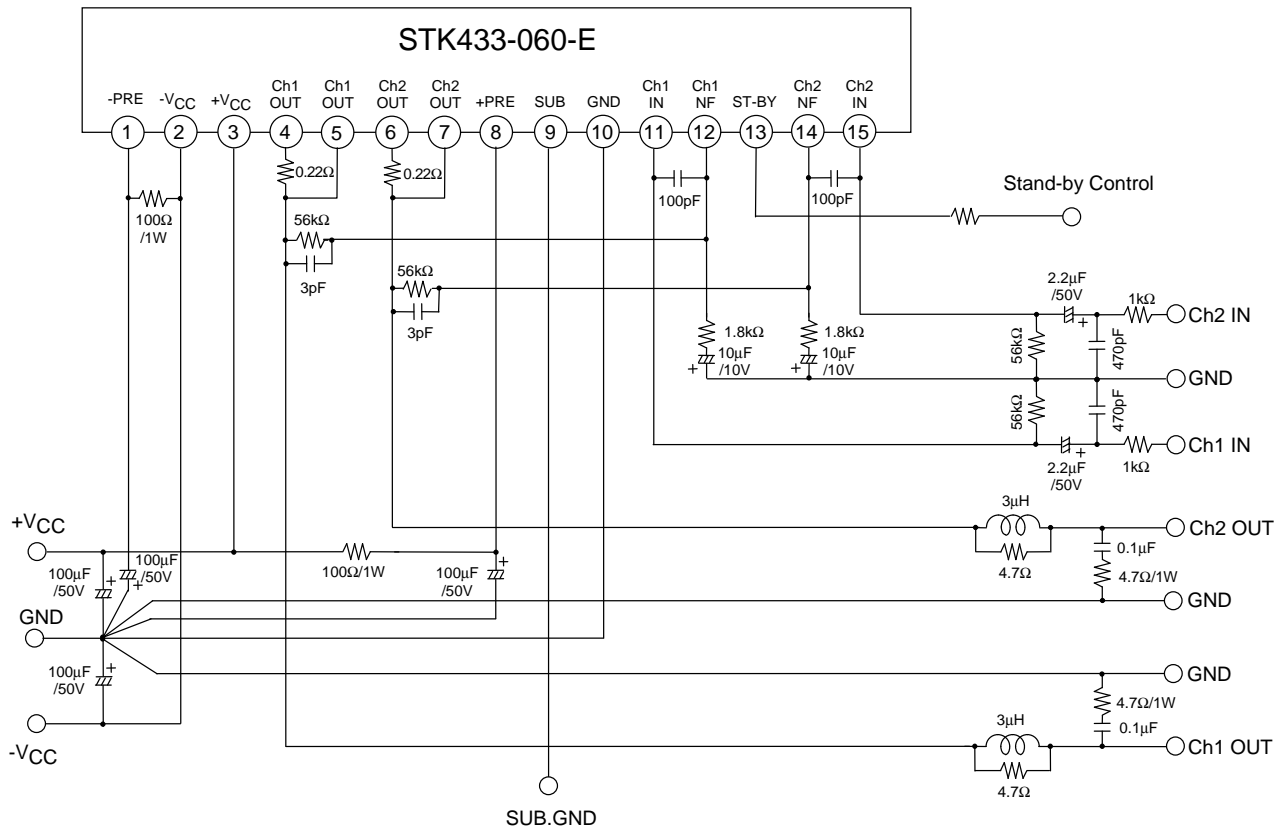

Sample PCB Trace Pattern

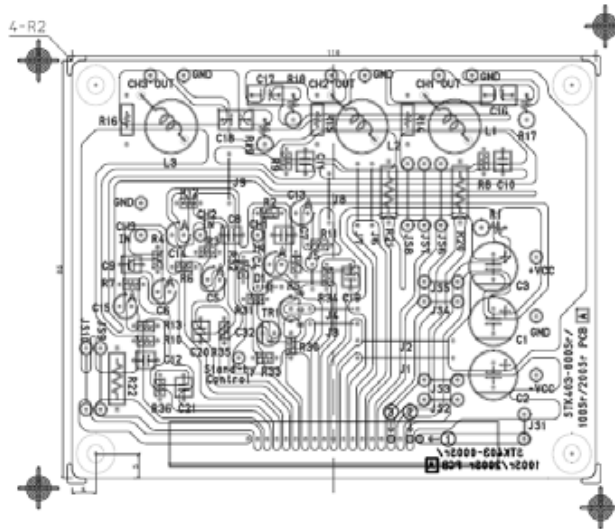

STK433-060-E

STK433-000/-200/STK403-100Sr PCB PARTS LIST

PCB Name: STK403-000Sr/100Sr/200Sr PCBA

Location No. (*3)	PARTS	RATING	Component		
			STK433-030/-040	STK433-060/-070	
			STK433-230/-240	STK433-260/-270	
				STK403-090 to130	
Hybrid IC#1 Pin Position	-	-	Ⓞ		
R01	ERG1SJ101	100Ω, 1W	enable		
R02, R03 (R4)	RN16S102FK	1kΩ, 1/6W	enable		
R05, R06, R08, R09 (R7, R10)	RN16S563FK	56kΩ, 1/6W	enable		
R11, R12 (R13)	RN16S182FK	1.8kΩ, 1/6W	enable		
R14, R15 (R16)	RN14S4R7FK	4.7Ω, 1/4W	enable		
R17, R18 (R19)	ERX1SJ4R7	4.7Ω, 1W	enable		
R20, R21 (R22)	ERX2SJR22	0.22Ω, 2W	short	enable	
C01, C02, C03	100MV100HC	100μF, 100V	enable		
C04, C05 (C06)	50MV2R2HC	2.2μF, 50V	enable (*1)		
C07, C08 (C09)	DD104-63B471K50	470pF, 50V	enable		
C10, C11 (C12)	DD104-63CJ030C50	3pF, 50V	enable (*2)		
C13, C14 (C15)	10MV10HC	10μF, 10V	enable (*1)		
C16, C17 (C18)	ECQ-V1H104JZ	0.1μF, 50V	enable		
C19, C20 (C21)	DD104-63B***K50	***pF, 50V	100pF		
R34, R35 (R36)	RN16S302FK	3kΩ, 1/6W	Short		
L01, L02 (L3)	-	3μH	enable		
Stand-By Control Circuit	Tr1	2SC2274 (Reference)	VCE≥50V, IC≥10mA		
	D1	GMB01 (Reference)	Di		
	R30	RN16S512FK	5.1kΩ, 1/6W	STK433-*00series	
		RN16S103FK	13kΩ, 1/6W	STK403-100series	
	R31	RN16S333FK	33kΩ, 1/6W	enable	
	R32	RN16S102FK	1kΩ, 1/6W	enable	
	R33	RN16S202FK	2kΩ, 1/6W	enable	
C32	10MV33HC	33μF, 10V	enable		
J1, J2, J3, J4, J5, J6, J8, J9	-	-	enable		
J7, JS2, JS3, JS4, JS5, JS7 JS8, JS9	-	-	-		
JS6, JS10	-	-	enable		
JS1	-	-	enable		

(*1) Capacitor mark "A" side is "-" (negative).

(*2) STK433-200Sr (3ch) is 8pF use.

(*3) Location No.() parts is STK433-200Sr (3ch) only use.

Evaluation Board Characteristics

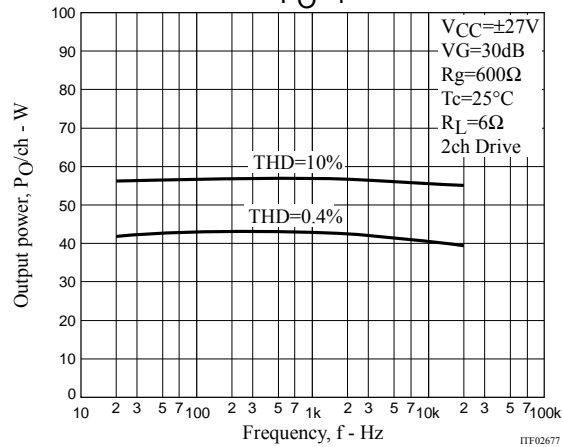
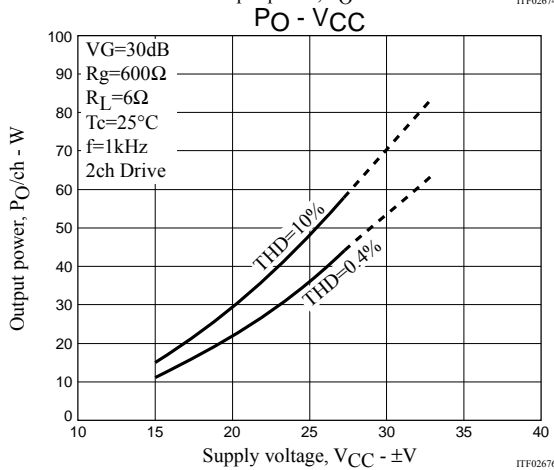
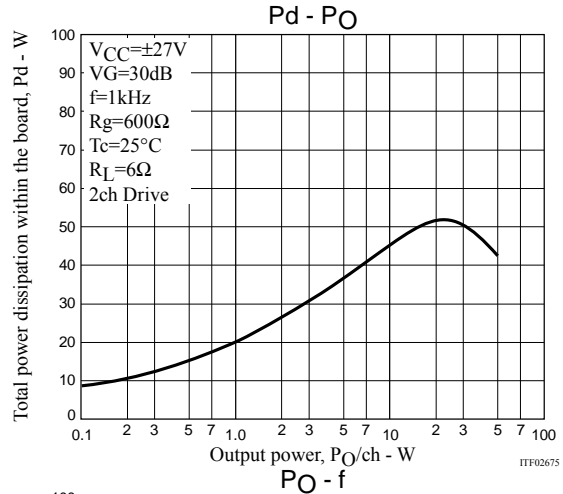
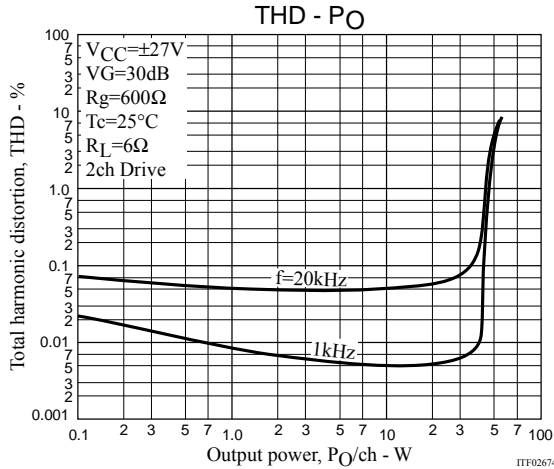

[Thermal Design Example for STK433-060-E (R_L = 6Ω)]

The thermal resistance, θ_{c-a}, of the heat sink for total power dissipation, Pd, within the hybrid IC is determined as follows.

Condition 1: The hybrid IC substrate temperature, T_c, must not exceed 125°C.

$$Pd \times \theta_{c-a} + Ta < 125^\circ C \dots\dots\dots (1)$$

Ta: Guaranteed ambient temperature for the end product

Condition 2: The junction temperature, T_j, of each power transistor must not exceed 150°C.

$$Pd \times \theta_{c-a} + Pd/N \times \theta_{j-c} + Ta < 150^\circ C \dots\dots\dots (2)$$

N: Number of power transistors

θ_{j-c}: Thermal resistance per power transistor

However, the power dissipation, Pd, for the power transistors shall be allocated equally among the number of power transistors.

The following inequalities result from solving equations (1) and (2) for θ_{c-a}.

$$\theta_{c-a} < (125 - Ta)/Pd \dots\dots\dots (1)'$$

$$\theta_{c-a} < (150 - Ta)/Pd - \theta_{j-c}/N \dots\dots\dots (2)'$$

Values that satisfy these two inequalities at the same time represent the required heat sink thermal resistance.

When the following specifications have been stipulated, the required heat sink thermal resistance can be determined from formulas (1)' and (2)'.

- Supply voltage V_{CC}
- Load resistance R_L
- Guaranteed ambient temperature Ta

STK433-060-E

[Example]

When the IC supply voltage, V_{CC} , is $\pm 27V$ and R_L is 6Ω , the total power dissipation, P_d , within the hybrid IC, will be a maximum of $52W$ at $1kHz$ for a continuous sine wave signal according to the P_d-P_O characteristics.

For the music signals normally handled by audio amplifiers, a value of $1/8P_O$ max is generally used for P_d as an estimate of the power dissipation based on the type of continuous signal. (Note that the factor used may differ depending on the safety standard used.)

This is:

$$P_d \approx 40W \quad (\text{when } 1/8P_O \text{ max.} = 6.25W, P_O \text{ max.} = 50W).$$

The number of power transistors in audio amplifier block of these hybrid ICs, N , is 4, and the thermal resistance per transistor, θ_{j-c} , is $3.5^\circ C/W$. Therefore, the required heat sink thermal resistance for a guaranteed ambient temperature, T_a , of $50^\circ C$ will be as follows.

$$\begin{aligned} \text{From formula (1)'} \quad \theta_{c-a} &< (125 - 50)/40 \\ &< 1.87 \end{aligned}$$

$$\begin{aligned} \text{From formula (2)'} \quad \theta_{c-a} &< (150 - 50)/40 - 3.5/4 \\ &< 1.62 \end{aligned}$$

Therefore, the value of $1.62^\circ C/W$, which satisfies both of these formulae, is the required thermal resistance of the heat sink.

Note that this thermal design example assumes the use of a constant-voltage power supply, and is therefore not a verified design for any particular user's end product.

STK433-000 Series Standby Control, Mute Control, Load-short Protection & DC offset Protection application

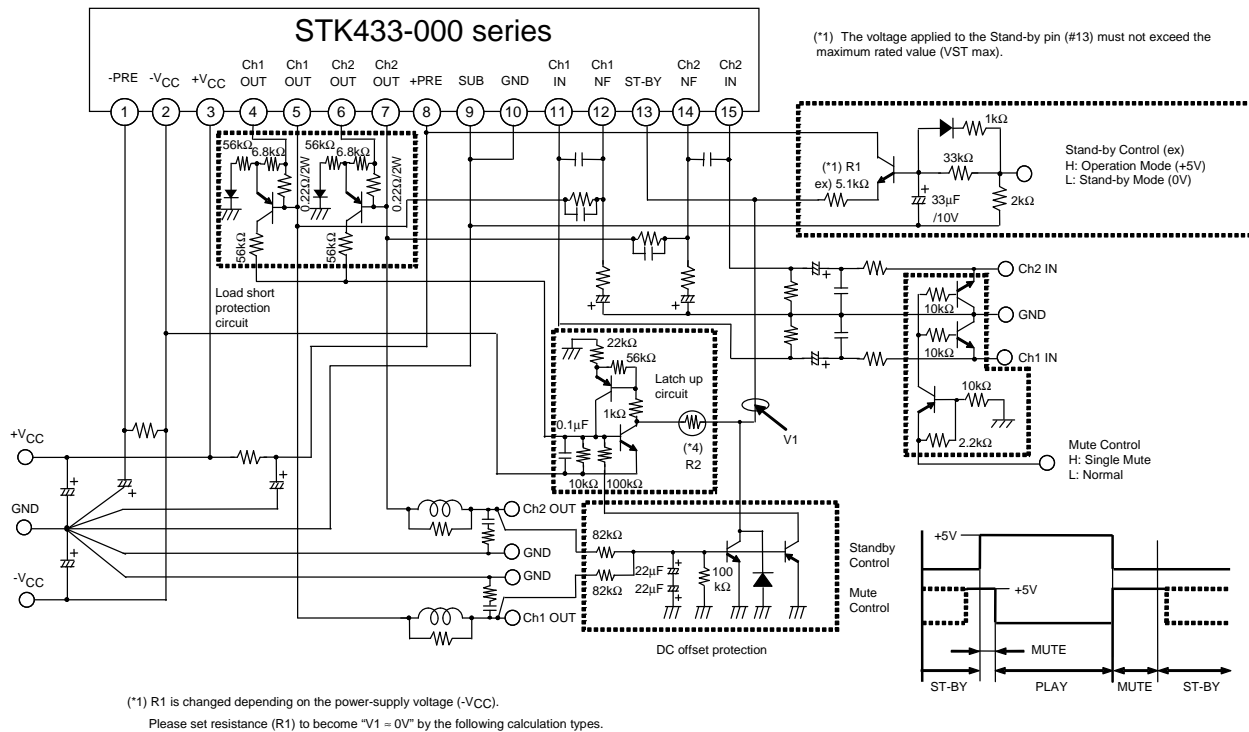

STK433-000 Series Application Explanation

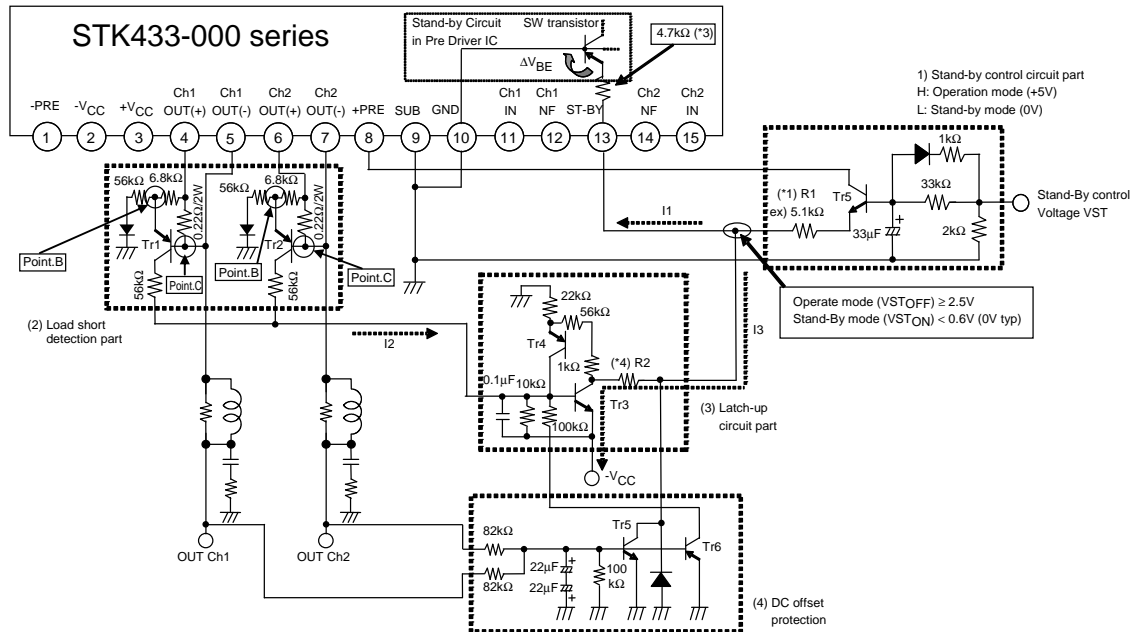

The protection circuit application for the STK433-000sr consists of the following blocks (blocks (1) to (4)).

- (1) Standby control circuit block
- (2) Load short-circuit detection block
- (3) Latch-up circuit block
- (4) DC voltage protection block

1) Standby control circuit block

Concerning pin 13 reference voltage VST

<1> Operation mode

The switching transistor of the predriver IC turns on when the pin 13 reference voltage, VST, becomes greater than or equal to 2.5V, placing the amplifier into the operation mode.

Example: When VST (min.) = 2.5V

$I1$ is approximately equal to 0.40mA since $VST = (*2) \times IST + 0.6V \rightarrow 2.5V = 4.7k\Omega \times IST + 0.6V$.

<2> Standby mode

The switching transistor of the predriver IC turns off when the pin 13 reference voltage, VST, becomes lower than or equal to 0.6V (typ. 0V), placing the amplifier into the standby mode.

Example: When VST = 0.6V

$I1$ is approximately equal to 0mA since $VST = (*2) \times IST + 0.6V \rightarrow 0.6V = 4.7k\Omega \times IST + 0.6V$.

(*1) Limiting resistor

Determine the value of R1 so that the voltage VST applied to the standby pin (pin 13) falls within the rating (+2.5V to 5.5V (typ. 3.0V)).

(*2) The standby control voltage must be supplied from the host including microcontrollers.

(*3) A 4.7kΩ limiting resistor is also incorporated inside the hybrid IC (at pin 13).

- SANYO Semiconductor Co.,Ltd. assumes no responsibility for equipment failures that result from using products at values that exceed, even momentarily, rated values (such as maximum ratings, operating condition ranges, or other parameters) listed in products specifications of any and all SANYO Semiconductor Co.,Ltd. products described or contained herein.
- SANYO Semiconductor Co.,Ltd. strives to supply high-quality high-reliability products, however, any and all semiconductor products fail or malfunction with some probability. It is possible that these probabilistic failures or malfunction could give rise to accidents or events that could endanger human lives, trouble that could give rise to smoke or fire, or accidents that could cause damage to other property. When designing equipment, adopt safety measures so that these kinds of accidents or events cannot occur. Such measures include but are not limited to protective circuits and error prevention circuits for safe design, redundant design, and structural design.
- In the event that any or all SANYO Semiconductor Co.,Ltd. products described or contained herein are controlled under any of applicable local export control laws and regulations, such products may require the export license from the authorities concerned in accordance with the above law.
- No part of this publication may be reproduced or transmitted in any form or by any means, electronic or mechanical, including photocopying and recording, or any information storage or retrieval system, or otherwise, without the prior written consent of SANYO Semiconductor Co.,Ltd.
- Any and all information described or contained herein are subject to change without notice due to product/technology improvement, etc. When designing equipment, refer to the "Delivery Specification" for the SANYO Semiconductor Co.,Ltd. product that you intend to use.
- Information (including circuit diagrams and circuit parameters) herein is for example only; it is not guaranteed for volume production.
- Upon using the technical information or products described herein, neither warranty nor license shall be granted with regard to intellectual property rights or any other rights of SANYO Semiconductor Co.,Ltd. or any third party. SANYO Semiconductor Co.,Ltd. shall not be liable for any claim or suits with regard to a third party's intellectual property rights which has resulted from the use of the technical information and products mentioned above.

This catalog provides information as of October, 2009. Specifications and information herein are subject to change without notice.