

Silicon NPN Power Transistors

2SC4804

DESCRIPTION

- With ITO-220 package
- High breakdown voltage

APPLICATIONS

- Switching regulator and high voltage switching applications
- High speed DC-DC converter applications

PINNING

PIN	DESCRIPTION
1	Base
2	Collector
3	Emitter

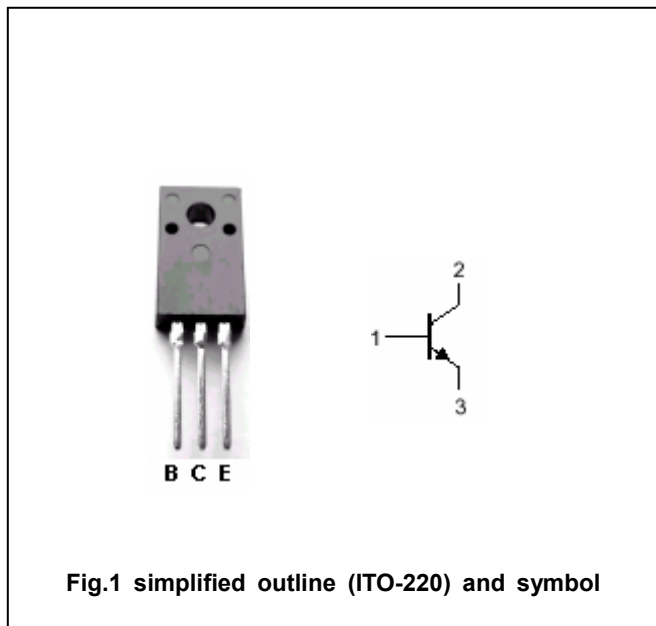

Fig.1 simplified outline (ITO-220) and symbol

Absolute maximum ratings(Ta=25°C)

SYMBOL	PARAMETER	CONDITIONS	VALUE	UNIT
V _{CBO}	Collector-base voltage	Open emitter	900	V
V _{CEO}	Collector-emitter voltage	Open base	600	V
V _{EBO}	Emitter-base voltage	Open collector	7	V
I _C	Collector current		3	A
I _{CM}	Collector current-Peak		5	A
I _B	Base current		1	A
P _T	Total power dissipation	T _C =25°C	30	W
T _j	Junction temperature		150	°C
T _{stg}	Storage temperature		-55~150	°C

Silicon NPN Power Transistors

2SC4804

CHARACTERISTICS

T_j=25°C unless otherwise specified

SYMBOL	PARAMETER	CONDITIONS	MIN	TYP.	MAX	UNIT
V _{(BR)CEO}	Collector-emitter breakdown voltage	I _C =10mA ; I _B =0	600			V
V _{(BR)CBO}	Collector-base breakdown voltage	I _C =1mA ; I _E =0	900			V
V _{(BR)EBO}	Emitter-base breakdown voltage	I _E =1mA ; I _C =0	7			V
V _{CEsat}	Collector-emitter saturation voltage	I _C =0.8A ; I _B =0.16A			0.6	V
V _{BEsat}	Base-emitter saturation voltage	I _C =0.8A ; I _B =0.16A			1.2	V
I _{CBO}	Collector cut-off current	V _{CB} =800V ; I _E =0			0.1	mA
I _{EBO}	Emitter cut-off current	V _{EB} =7V ; I _C =0			0.1	mA
h _{FE}	DC current gain	I _C =0.8A ; V _{CE} =5V	10			

Silicon NPN Power Transistors

2SC4804

PACKAGE OUTLINE

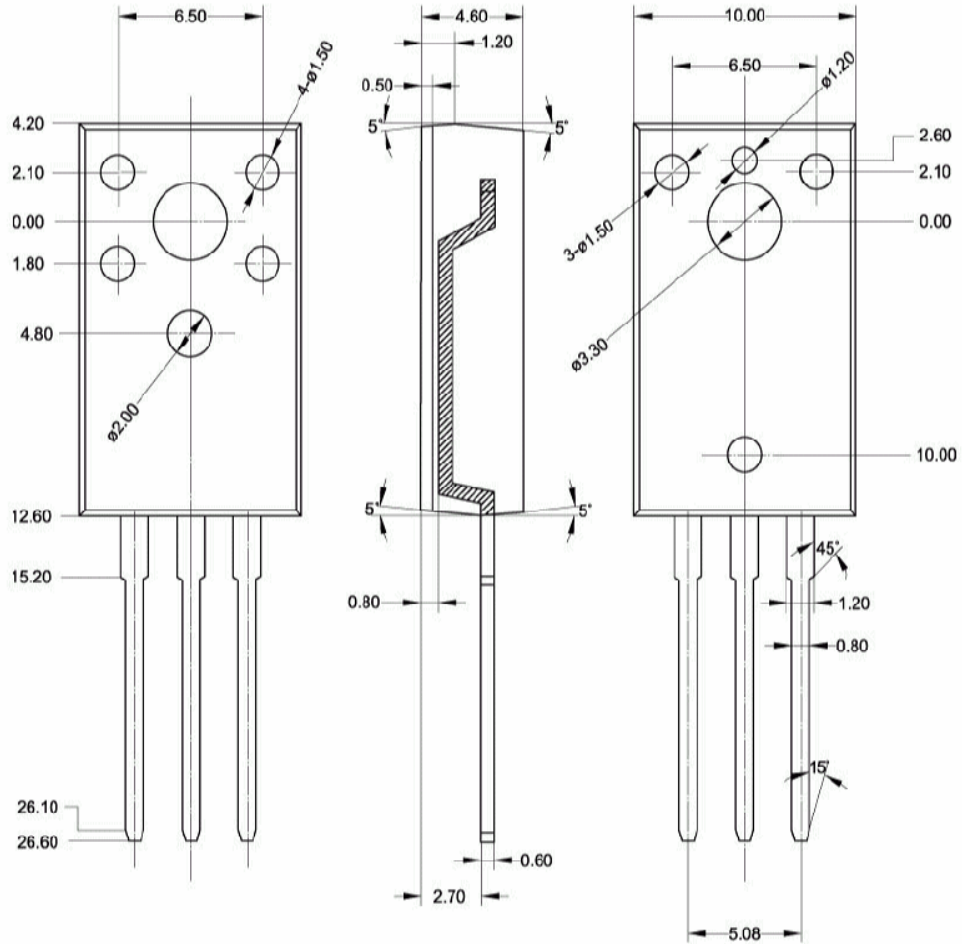

Fig.2 Outline dimensions (unindicated tolerance: ± 0.20 mm)